

**QWEST Communications
International Inc.
Technical Publication**

**QWEST DIGITAL SWITCHED
SERVICE**

NOTICE

Technical Publication 77319 *QWEST Digital Switched Service* provides information about Digital Switched Service and the various ways that it can be integrated with other QWEST services. The Digital Switched Service (DSS) interface to the customer is a Digital Signal Level 1 (DS1) Channel at 1.544 Mbit/s transmission rate. Pub 77319 is intended to be used with Technical Publication 77375, *1.544 Mb/s Channel Interfaces*.

QWEST Communications International Inc. reserves the right to revise this document for any reason, including but not limited to, conformity with standards promulgated by various governmental or regulatory agencies; utilization of advances in the state of the technical arts; or to reflect changes in the design of equipment, techniques, or procedures described or referred to herein.

Liability to anyone arising out of use or reliance upon any information set forth herein is expressly disclaimed, and no representation or warranties, expressed or implied, are made with respect to the accuracy or utility of any information set forth herein.

This document is not to be construed as a suggestion to any manufacturer to modify or change any of its products, nor does this publication represent any commitment by QWEST Communications International Inc. to purchase any specific products. Further, conformance to this publication does not constitute a guarantee of a given supplier's equipment and/or its associated documentation.

Future issues of Technical Document 77319 will be announced to the industry at least 45 days prior to the issuance date. This notice, which will come through our standard customer notification channels, will allow the customer time to comment on the proposed revisions.

Ordering information for QWEST Publications can be obtained from the Reference Section of this document.

If further information is required, please contact:

QWEST Communications International Inc.
Manager – New Services Planning
700 W. Mineral Ave. MN-F15.15
Littleton, CO 80120
(303) 707-7107
(303) 707-9497 Fax #
E-mail: jhsmit2@qwest.com

Throughout this publication, the term QWEST signifies QWEST Communications International Inc.

COMMENTS on PUB 77319

PLEASE TEAR OUT AND SEND YOUR COMMENTS/SUGGESTIONS TO:

QWEST Corporation
Manager - New Services Planning
700 W. Mineral Ave. MN-F15.15
Littleton, CO 80120
(303) 707-7107
(303) 707-9497 Fax #
E-mail: jhsmit2@qwest.com

Information from you helps us to improve our Publications. Please take a few moments to answer the following questions and return to the above address.

Was this Publication valuable to you in understanding
The technical parameters of our service? YES _____ NO _____

Was the information accurate and up-to-date? YES _____ NO _____

Was the information easily understood? YES _____ NO _____

Were the contents logically sequenced? YES _____ NO _____

Were the tables and figures understandable and helpful YES _____ NO _____

Were the pages legible? YES _____ NO _____

If you answered NO to any of the questions and/or if you have any other comments or suggestions, please explain:

(Attach additional sheet, if necessary)

Name _____ Date _____

Company _____

Address _____

Telephone Number _____

E-Mail _____

CONTENTS

Chapter and Section	Page
1. Introduction.....	1-1
1.1 General	1-1
1.2 Reason For Reissue	1-1
1.3 Scope.....	1-1
1.4 Publication Organization	1-1
2. Overview of QWEST Digital Switched Service.....	2-1
2.1 Service Description.....	2-1
2.2 Basic DSS.....	2-2
2.3 Advanced DSS.....	2-3
2.4 Mixed Basic and Advanced Services Option.....	2-3
2.5 Availability	2-4
2.6 Benefits.....	2-4
3. QWEST Services or Features Offered with DSS.....	3-1
3.1 Clear Channel Capability.....	3-1
3.2 Interoffice Digital Switched Service.....	3-1
3.3 DSS With Self-Healing Alternate Route Protection (SHARP).....	3-2
3.4 DSS with SHARP Service and SHNS.....	3-2
3.5 Advanced DSS with Two-way Digital Data Trunk.....	3-3
3.6 Basic DSS with Wide Area Telecommunications Service.....	3-3
4. Network Channel/Network Channel Interface Codes	4-1
4.1 Network Channel (NC) Codes.....	4-1
4.1.1 General	4-1
4.1.2 Format.....	4-1
4.2 Network Channel Interface (NCI) Codes.....	4-2
4.1.1 General	4-2
4.1.2 Format.....	4-2
5. Compatible NC and NCI Code Combinations.....	5-1
5.1 Order the DS1 Channel.....	5-1
5.2 Order the Lower Channel	5-2
5.2.1 When Ordering Basic DSS.....	5-2
5.2.2 When Ordering ISDN (SLS) with Basic DSS.....	5-3
5.2.3 When Ordering Advanced DSS	5-3

CONTENTS (Continued)

Chapter and Section	Page
6. Compatible NC and NCI Code Combinations for features of DSS.....	6-1
6.1 DSS with Self Healing Alternate Route Protection (SHARP).....	6-1
6.1.1 Order the High Capacity Channel.....	6-1
6.1.2 Order the Lower Channel.....	6-2
6.2 DSS Assigned to DS3 Service.....	6-2
6.3 Advanced DSS with Two-Way Digital Data Trunk.....	6-2
6.3.1 Ordering the DS1 Channel.....	6-3
6.3.2 Order Advanced DSS.....	6-3
6.3.2 Order the Two-Way Digital Data Trunk.....	6-3
7. Definitions.....	7-1
7.1 Acronyms.....	7-1
7.2 Glossary.....	7-2
8. References.....	8-1
8.1 American National Standards Institute Documents.....	8-1
8.2 QWEST Technical Publications.....	8-1
8.3 Other Publications.....	8-1
8.4 Ordering Information.....	8-2
8.5 Trademarks.....	8-2

CONTENTS (Continued)

Figures	Page
2-1 Network Interface of Digital Switched Service.....	2-1
2-2 General Digital Switched Service Design.....	2-2
2-3 All Basic Digital Switched Service	2-3
2-4 All Advanced Digital Switched Service.....	2-4
3-1 Interoffice Digital Switched Service.....	3-1
3-2 Digital Switched Service with Self-Healing Alternate Route Protection	3-2
4-1 NCI Impedance Values.....	4-3
 Tables	
4-1 Format Structure for NC Codes	4-1
4-1 Format Structure for NCI Codes.....	4-2
5-1 Codes for Ordering the DS1 or Digital High Capacity Channel.....	5-1
5-2 Codes for Ordering Basic DSS Trunks.....	5-2
5-3 Code for Ordering ISDN (SLS) with Basic DSS.....	5-3
5-4 Codes for Ordering Advanced DSS Trunks	5-4
5-5 Trunk Selection Algorithms for Advanced DSS.....	5-4
6-1 Codes for Ordering DSS with SHARP	6-1
6-2 Codes for Ordering DSS with DS3.....	6-2
6-2 Codes for Ordering Advanced DSS with Two-Way Digital Data Trunk	6-3

CONTENTS

Chapter and Section	Page
1. Introduction.....	1-1
1.1 General	1-1
1.2 Reason For Reissue	1-1
1.3 Scope	1-1
1.4 Publication Organization	1-2

1. Introduction

1.1 General

Technical Publication 77319 *QWEST Digital Switched Service* provides information about Digital Switched Service and the various ways that it can be integrated with other QWEST services. The Digital Switched Service (DSS) interface to the customer is a Digital Signal Level 1 (DS1) Channel at 1.544 Mbit/s transmission rate. Pub 77319 is intended to be used with Technical Publication 77375, *1.544 Mb/s Channel Interfaces* and 77200 *QWEST DS1 Service and QWEST DS1 Rate Synchronization Service*.

1.2 Reason for Reissue

This publication is being reissued to:

- Update the Company information from U S WEST to QWEST.

1.3 Scope

Digital Switched Service is often described as digital Private Branch Exchange (PBX) *trunks* because it provides channelized DS1 connectivity between the customer's PBX and the QWEST's switch. Digital Switched Service offers four fundamental options: Basic DSS, ISDN (SLS) with Basic DSS, Advanced DSS, or Mixed DSS, where each option has its own features.

This publication is organized by and defines the four available options when ordering Digital Switched Service. The publication also provides the Network Channel (NC) and Network Channel Interface (NCI) codes and their definitions associated with DSS options. The document also includes other services that can be integrated with DSS and the NC and NCI code combinations to assist customers in ordering the service(s).

1.4 Publication Organization

- Chapter 1 **Introduction**, provides the purpose and general information about this document.
- Chapter 2 **Overview of QWEST Digital Switched Service**, describes the service and its options.
- Chapter 3 **QWEST Services and Features Offered With DSS**, provides other services and enhancements in which Digital Switched Service can be integrated.
- Chapter 4 **Network Channel and Network Channel Interface Codes**, provide a general explanation of the codes.
- Chapter 5 **Compatible NC and NCI Code Combinations**, illustrates compatible NC and NCI code combination tables for ordering the services described in the chapter.
- Chapter 6 **Compatible NC and NCI Code Combinations for Features of DSS**, provides additional compatible NC and NCI code combination tables for ordering special options of DSS.
- Chapter 7 **Definitions and Acronyms**
- Chapter 8 **References**

CONTENTS

Chapter and Section	Page
2. Overview of QWEST Digital Switched Service.....	2-1
2.1 Service Description.....	2-1
2.2 Basic DSS.....	2-2
2.3 Advanced DSS.....	2-3
2.4 Mixed Basic and Advanced Services Option.....	2-3
2.5 Availability.....	2-4
2.6 Benefits.....	2-4

Figures

2-1 Network Interface of Digital Switched Service.....	2-1
2-2 General Digital Switched Service Design.....	2-2
2-3 All Basic Digital Switched Service.....	2-3
2-4 All Advanced Digital Switched Service.....	2-4

2. Overview of QWEST Digital Switched Service

This chapter provides an overview of Digital Switched Service (DSS) and discusses different options that are offered with DSS. It is a high capacity, high performance information channel designed to perform multiple functions. It is a dedicated, end-to-end digital transport service designed for full duplex, point-to-point transmission at 1.544 Mbit/s. It consists of 24 Digital Signal Level 0 (DS0) channels (64kb/s each) which can be utilized to provide different services.

DSS offers digital transport within QWEST's territory. The network links the population centers of this vast geographic region together to provide virtually unlimited service to subscribers wherever they reside or do business. This service can offer increased value to subscribers because it provides security, reliability, protection, and rate stability.

2.1 Service Description

Digital Switched Service provides a channel that transmits a digital signal at the rate of 1.544 Mbit/s between the customer premises and QWEST's serving wire center switch. This DS1 channel at the Network Interface is also referred to as a Digital High Capacity Channel. More information on Network Interface (NI) can be obtained from QWEST Technical Publication 77375. The service allows customers to "channelize" the DS1 into twenty-four 64 kbits/s lower channels using their Customer Premises Equipment (CPE). The CPE includes a Private Branch Exchange (PBX) or an Automatic Call Distributor (ACD). Figure 2-1 describes the general DSS design.

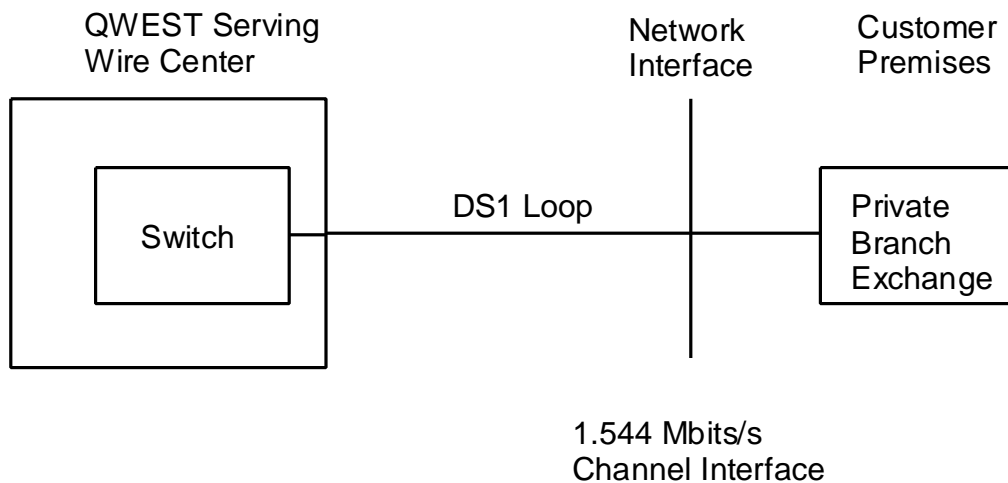

Figure 2-1 General Digital Switched Service Design

Customers who own a PBX or an ACD may purchase DSS to send a multiple of twenty-four 64 kbits/s voice or data channels. These “64 kbits/s channels” are commonly referred to as **trunks**. *To improve clarity and minimize confusion between a DS1 channel, which is the network interface of DSS, and a 64 kbits/s channel, which is generated by the CPE, this publication will sometimes use the word trunk to indicate a 64 kbits/s channel.* The customer assigns a number of these trunks to the line side or the trunk side of QWEST’s central office switch. The two terminations within the switch, the line interface unit versus the trunk interface unit, determine the DSS options: *Basic DSS* and *Advanced DSS*.

The Basic DSS option indicates that the trunks from the CPE terminate on the line unit of the switch. Conversely, the Advanced DSS option indicates that the trunks terminate on the trunk unit of the switch. Customers may order one or the other, or a combination of both services called *Mixed DSS*. In addition, customers can also order ISDN (SLS) on the spare channels along with Basic DSS.

2.2 Basic DSS

For Basic DSS, QWEST terminates the DS1 into the line unit of the switch using a multiplexer. The customer premises equipment (CPE) derives the twenty-four 64 kbits/s trunks within the DS1. Figure 2-2 illustrates this application.

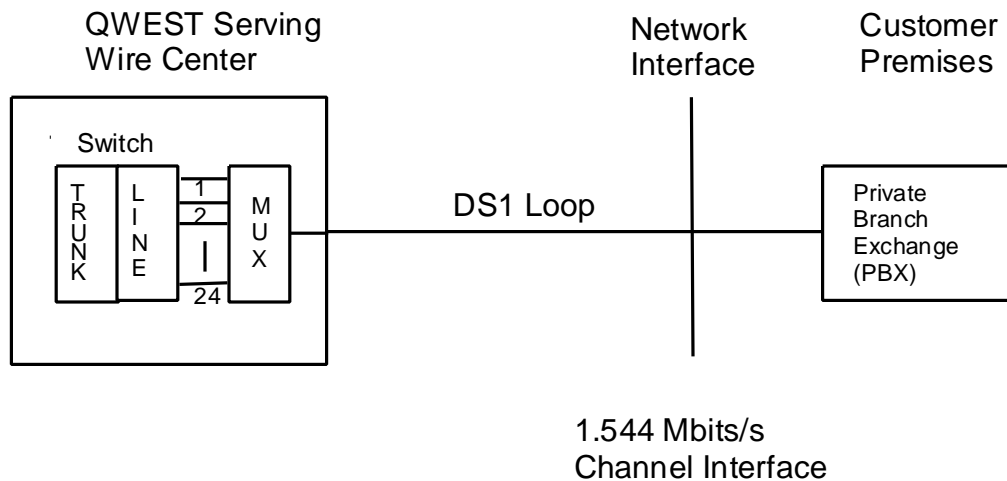

Note: The multiplexing function may or may not reside within the switch

Figure 2-2 All Basic Digital Switched Service

The customers can also order ISDN (SLS) service on the spare channels that are not utilized for Basic DSS. The ISDN (SLS) utilizes three consecutive DS0 channels on a DS1 to provide two primary 64 kbits/s or B channels. These channels can be used simultaneously and independently to carry any combination of voice, data, image or video calls. It also provides a third, secondary 16 kbits/s or D channel for low to moderate-speed data communications.

2.3 Advanced DSS

The option of terminating the DS1 into the trunk unit of the switch is referred to as Advanced DSS. It is CPE that derives the twenty-four 64 kbits/s trunks within the

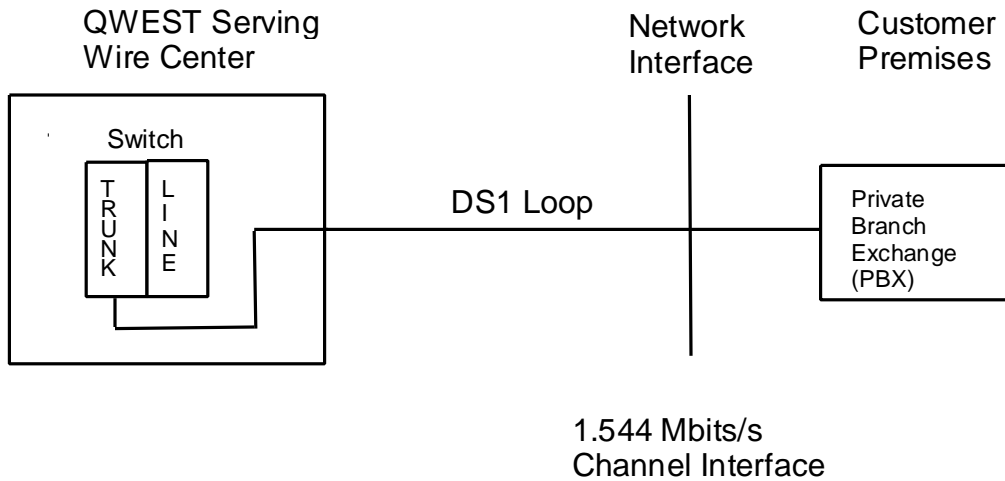

Note: The multiplexing function may or may not reside within the switch DS1. Figure 2-3 displays this application.

Figure 2-3 All Advanced Digital Switched Service

2.4 Mixed Basic and Advanced Services Option

Customers may allocate a combination of their CPE derived 64 kbits/s channels within the DS1 to terminate on the trunk unit and the line unit of the switch. Figure 2-4

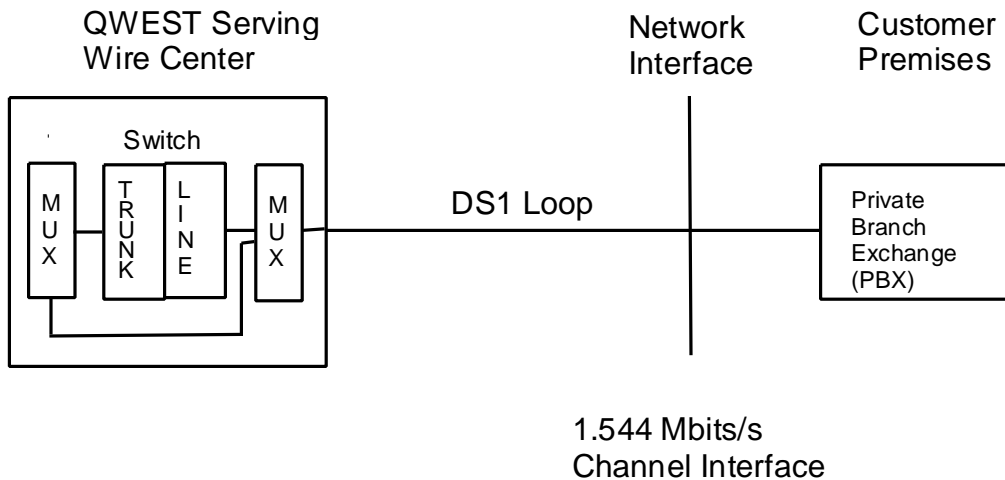

Note: The multiplexing function may or may not reside within the switch describes this offering.

Figure 2-4 Mixed (Basic and Advanced) Digital Switched Service

2.5 Availability

DSS is provided from both QWEST analog or digital switches, thereby making the service available across the QWEST 14-state region. DSS has been filed under the State Tariffs only and therefore offered within state jurisdictions. Customers may refer to the Local Exchange and Network Services Tariff from their state's Public Utilities Commission Office for DSS offering and pricing information.

DSS availability is only limited when the customer requests it to be delivered on a fiber facility, or when the customer is ordering DSS in conjunction with other services that require fiber facility to be in place e.g., SHARP or SHNS services described in the next chapter. In these unique instances, customers are advised to consult with the QWEST's Business Office and begin the service inquiry process on an individual case basis. The QWEST Customer Representative can then determine if facilities are available and provide a date of when the service can be offered.

2.6 Benefits

Digital Switched Service offers many benefits to potential customers who:

- Currently own a digital PBX
- Plan to purchase a new digital PBX or grow their existing PBX
- Want to save capital expense up front on the purchase of a new PBX
- Want the reliability and low error rate of digital transmission
- Want greater trunking efficiency
- Want precision timing for call accounting software
- Use dial-up data or direct 56 kbits/s transmission
- Want to update to current technology
- Need a low dB loss level on trunks
- Want WATS/800 Service to be used with DSS

CONTENTS

Chapter and Section	Page
3. QWEST Services or Features Offered with DSS.....	3-1
3.1 Clear Channel Capability.....	3-1
3.2 Interoffice Digital Switched Service.....	3-1
3.3 DSS With Self-Healing Alternate Route Protection (SHARP).....	3-2
3.4 DSS with SHARP Service and SHNS.....	3-2
3.5 Advanced DSS with Two-way Digital Data Trunk.....	3-3
3.6 Basic DSS with Wide Area Telecommunications Service.....	3-3

Figures

3-1 Interoffice Digital Switched Service.....	3-1
3-2 Digital Switched Service with Self-Healing Alternate Route Protection	3-2

3. QWEST Services or Features Offered with DSS

3.1 Clear Channel Capability

DS1 transmission has requirements on the minimum number of binary zeros that should be consecutively transmitted. This is commonly expressed as the inverse, which is *ones density*. When ones density becomes too low, recovery of the DS1 signal by receivers becomes more difficult. Jitter increases and bit errors will result. Simultaneously, network equipment may respond by generating alarms, alerting maintenance personnel of a service problem. Low ones density in any portion of the DS1 signal will affect all the channels in the DS1.

DS1 Clear Channel denotes that a 1's density management process is active in the terminal and transmission equipment, so that user data can contain any number of consecutive binary 0's. When the following are being transported, it may be advisable to use a DS1 Clear Channel option to assure a suitable level of 1's density:

- 64 kbit/s digital data
- Aggregations of 64 kbit/s for video transmission (384 kbit/s, 768 kbit/s, etc.)
- Aggregations of 64 kbit/s for Nx64 bandwidths of digital data where N = 2 to 24.

The conventional mean of providing DS1 Clear Channel is to use the B8ZS (binary 8 zero substitution) line code.

3.2 Interoffice Digital Switched Service

Customers have the flexibility of requesting a specific QWEST wire center to provide DSS, rather than from their serving wire center. The service design is identical to Figure 2-1, except that there would be one additional rate element for the interoffice transport facility. The interoffice facility is between the remote switch and the serving wire center. The multiplexing function of the DS1 channel occurs in the same wire center as switch. Figure 3-1 illustrates this application.

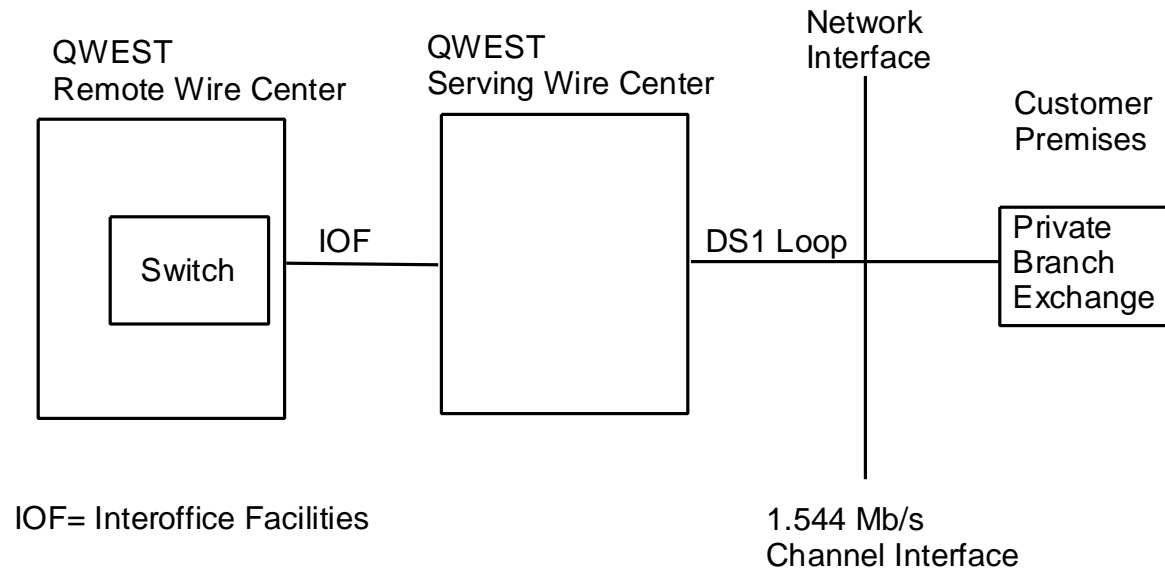

Figure 3-1 Interoffice Digital Switched Service

3.3 DSS with Self Healing Alternate Route Protection (SHARP)

SHARP is an optional service that improves the reliability of DSS that is transported over fiber optic facilities. This feature provides a separate facility path for the protection system between the serving wire center and the customer premises. Special construction charges apply when fiber facility is not in place. Figure 3-2 describes this configuration.

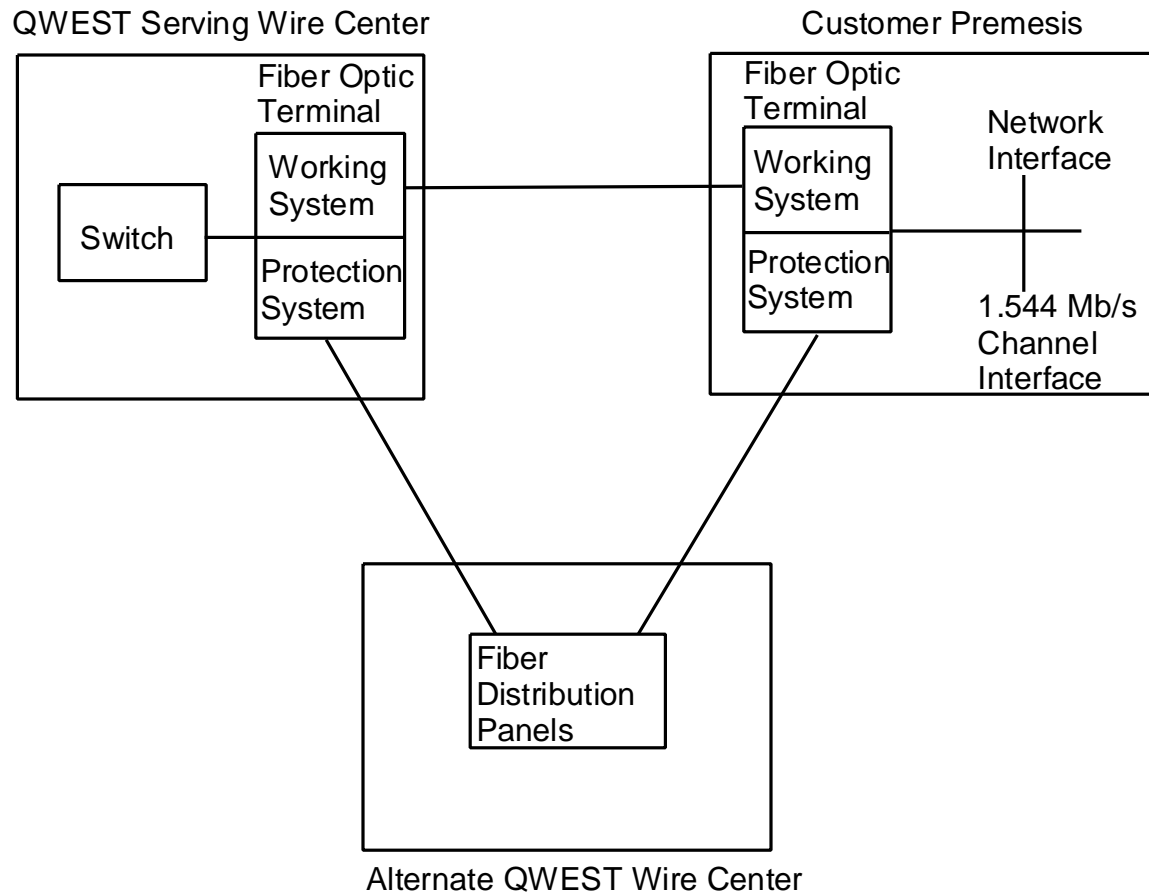

Figure 3-2 Digital Switched Service with Self-Healing Alternate Route Protection

3.4 DSS with SHARP Service and SHNS

Customers may also order DSS in conjunction with Self-Healing Alternate Route Protection (SHARP) Service or Self-Healing Network Service (SHNS). Chapter 6 provides more details on ordering SHARP Service and SHNS. These services are offered in the following combinations:

- Intrastate Tariff - DSS with DS1 SHARP Service
- Interstate Tariff - DSS with DS3 SHARP Service
- DSS with DS3 and SHNS

Technical descriptions of the services are available in QWEST's Technical Publication 77340 for SHARP Service and Publication 77332 for SHNS. Special construction charges apply when fiber facility is not in place.

3.5 Advanced DSS with Two-way Digital Data Trunk

In choosing the Advanced DSS, customers may allocate a portion of the trunks to be Two-way Digital Data Trunk. This service option is identical to QWEST SwitchNet 56® Service and tariffed in FCC #5.

3.6 Basic DSS with Wide Area Telecommunications Service (WATS)

Customers may purchase QWEST's WATS, 800 Service, or OutWATS and assign any number of Basic DSS trunks for these services. WATS provides dedicated analog access lines for customers who have substantial long distance usage. The 800 Service is a form of WATS, which permit only incoming calls. More information is available in QWEST's Technical Publication 77318.

CONTENTS

Chapter and Section	Page
4. Network Channel/Network Channel Interface Codes	4-1
4.1 Network Channel (NC) Codes	4-1
4.1.1 General	4-1
4.1.2 Format.....	4-1
4.2 Network Channel Interface (NCI) Codes.....	4-2
4.1.1 General	4-2
4.1.2 Format.....	4-2
Figures	
4-1 Format Structure for NC Codes	4-1
4-1 Format Structure for NCI Codes.....	4-2
Tables	
4-1 NCI Impedance Values.....	4-3

4. Network Channel/Network Channel Interface Codes

4.1 Network Channel (NC) Codes

4.1.1 General

Network Channel (NC) codes are a part of the Bellcore COMMON LANGUAGE® code set. The NC code is used to identify a channel used with the service. This section identifies the available channels and their NC codes.

4.1.2 Format

An NC code is a four-character code with two data elements:

- Channel Code
- Optional Feature Code

The format is illustrated in Figure 4-1.

Network Channel Code				
Data Element	Channel Code		Optional Feature Code	
Character Position	1	2	3	4
Character Key	X	X	X or -	X or -

X = Alphanumeric
- = Hyphen

Figure 4-1 Format Structure for NC Codes

The **Channel Code** (character positions 1 and 2) is a two-character alpha or alphanumeric code that describes the channel service in an abbreviated form. The channel code will frequently, but not always, be specified as the service code of the special service circuits or the transmission grade of the message trunk circuit. The NC channel code field is always filled.

The **Optional Feature Code** (character positions 3 and 4) is a two-character alpha or alphanumeric or hyphen code that represents the option codes available for each channel code. Varying combinations of this code will allow the customer to enhance the technical performance of the requested channel, or to further identify the type of service. It is also used to specify options such as conditioning, effective 4-wire, multiplexing, etc. The NC optional code field is always filled.

Further information about NC Codes may be found in ANSI T1.223-1997, *Information Interchange — Structure and Representation of Network Channel (NC) and Network Channel Interface (NCI) Codes for the North American Telecommunications System*.

4.2 Network Channel Interface (NCI) Codes

4.2.1 General

Network Channel Interface (NCI) codes are a part of the COMMON LANGUAGE® code set. The NCI code is used to identify a network interface of a service in our mechanized systems.

4.2.2 Format

An NCI code is a maximum twelve-character code that consists of five (5) data elements:

- Total Conductors
- Protocol
- Impedance
- Protocol Options
- Transmission Level Point(s) (TLP) - not required for this digital service.

The first three fields are required. The last two are optional. The format is illustrated in Figure 4-2.

Network Channel Interface Code

Total Conductors		Protocol		I m p e d a n c e	D e l i m i t e r	Protocol Options			D e l i m i t e r	TLP Level	
										T r a n s m i t	R e c e i v e
1	2	3	4	5	6	7	8	9	10	11	12
N	N	A	A	X	•	X	X	X	•	X or -	X or -

- A = Alpha
- N = Numeric
- X = Alphanumeric
- = Delimiter (normally a period)
- = Hyphen

Figure 4-2 Format Structure for NCI Codes

Total Conductors (character positions 1 and 2) is a two-character numeric code that represents the total number of physical conductors (e.g., wires or fibers) required at the interface.

Protocol (character position 3 and 4) is a two-character alpha code that defines requirements for the interface regarding signaling/transmission.

Impedance (character position 5) is a one-character alpha or numeric code representing the nominal reference impedance that will terminate the channel for the purpose of evaluating transmission performance. Values are listed in Table 4-1.

Table 4-1 NCI Impedance Values

Impedance in Ohms (Character Position 5)			
Data Value	Code	Data Value	Code
110	0	124	7
150	1	Variable	8
600	2	100	9
900	3 *	Fiber	F
1200	4	Radio	Z
135	5	50 Coaxial	C
75	6		

* Except for interface code 04DD3, the impedance character 3, when used with a 4-wire voice-frequency path at the POT, denotes a historical customer (IC) provided transmission termination rather than a 900 ohm impedance. Such terminations were provided by customers in accordance with FCC Docket No. 20099 settlement Agreement and by Automatic Transmission Test and Control Circuit used in the previous provisioning process.

Protocol Options (character positions 7, 8, and 9) is a one to three-character alpha, numeric, or alphanumeric code that describes additional features (e.g., bit rate or bandwidth) on the Protocol to be used. It is an optional field that is always left justified.

CONTENTS

Chapter and Section	Page
5. Compatible NC and NCI Code Combinations	5-1
5.1 Order the DS1 Channel.....	5-1
5.2 Order the Lower Channel	5-2
5.2.1 When Ordering Basic DSS.....	5-2
5.2.2 When Ordering ISDN (SLS) with Basic DSS.....	5-4
5.2.3 When Ordering Advanced DSS	5-4
Tables	
5-1 Codes for Ordering the DS1 or Digital High Capacity Channel.....	5-2
5-2 Codes for Ordering Basic DSS Trunks.....	5-3
5-3 Code for Ordering ISDN (SLS) with Basic DSS.....	5-4
5-4 Codes for Ordering Advanced DSS Trunks	5-5
5-5 Trunk Selection Algorithms for Advanced DSS.....	5-5

5. Compatible NC and NCI Code Combinations

The tables in this chapter provide code combinations for ordering Digital Switched Service. The Network Channel (NC) and Network Channel Interface (NCI) codes listed in the same row for each table indicate that these codes are compatible and can be interchanged. When the codes are listed in different rows, they are not compatible.

This chapter also provides the sequence of ordering Digital Switched Service (DSS) to better guide the customer. The major ordering steps are identified in each subsequent sections.

5.1 Order the DS1 Channel

The DS1 channel connects the customer premises terminal to U S WEST's serving wire center where the 24 channels in the 1.544 Mbit/s bitstream are multiplexed and demultiplexed to and from 24 individual channels. This DS1 channel is also referred to as a Digital High Capacity channel.

Customers have various options in selecting the 1.544 Mbit/s interface based on signal characteristics, line codes, framing, and physical connections. The technical specifications of these interfaces are described in Technical Publication 77375, *U S WEST 1.544 Mbit/s Channel Interfaces*.

To order the DS1 channel, refer to Table 5-1. In column A, locate the row having the required equipment options. Obtain the NC code from column C. Obtain from column D the NCI code for each end of the channel. It should be noted that the Frame Format and Line Code availability depends on the switch type in the serving wire center.

Table 5-1 Codes for Ordering the DS1 or Digital High Capacity Channel

	A	B	C	D
	Equipment Frame Format and Line Code	Other Options	NC Code	NCI at End-User Premises
1	SF & AMI	Direct Digital Connection to a Switch	HC-D	04DU9.BN 04DU9.BX
2	SF & AMI	CO Multiplexed, Analog and Digital - to DS0	HC-G	04DU9.BN 04DU9.BX
3	ANSI ESF & AMI	Direct Digital Connection to a Switch	HCDD	04DU9.KN 04DU9.KX
4	ANSI ESF & AMI	CO Multiplexed, Analog and Digital - to DS0	HCDG	04DU9.KN 04DU9.KX
5	ANSI ESF & B8ZS	Direct Digital Connection to a Switch	HCED	04DU9.1SN 04DU9.1SX
6	ANSI ESF & B8ZS	CO, Multiplexed, Analog and Digital to DS0	HCEG	04DU9.CN 04DU9.CX
7	Non-ANSI ESF & AMI	Direct Digital Connection on a Switch	HCFD	04DU9.CN 04DU9.CX
8	Non-ANSI ESF & AMI	CO Multiplexed, Analog and Digital - to DS0	HCFG	04DU9.CN 04DU9.CX
9	Non-ANSI ESF & B8ZS	Direct Digital Connection to a Switch	HCGD	04DU9.CN 04DU9.CX
10	Non-ANSI ESF & B8ZS	CO Multiplexed, Analog and Digital - to DS0	HCGG	04DU9.SX

5.2 Order the Lower Channels

The next two sections describe the NC codes used to order Basic DSS, Advanced DSS, or Mixed DSS lower channels. The lower channels are also known as *trunks*. NCI codes are not applicable when ordering DSS trunks.

5.2.1 When Ordering Basic DSS

The customer shall select the following options for Basic Service.

- Supervisory Signaling - two choices
 1. Loop-Start
 2. Ground-Start

- Call Origination - three choices
 1. In-Only. Traffic from the switch is transmitted towards the customer premises equipment.
 2. Out-Only. Traffic from the customer premises equipment is transmitted towards the switch.
 3. Two-Way. Traffic that is transmitted from either the switch or customer premises equipment.

To order the lower channels or trunks for Basic DSS, refer to Table 5-2. In column A, locate the row having the required technical performance or features of the requested channel. Obtain the NC Code from column C for each lower channel.

Table 5-2 Codes for Ordering Basic DSS Trunks

	A	B	C
	Voice Grade Channel Service	Technical Performance	NC Code
1	Voice Line Transmission Characteristics & CO Switching	Loop Start, DTMF, & 2-Way	UCGF
2	Voice Line Transmission Characteristics & CO Switching	Loop Start, DTMF, & In-Only (Terminate Only)	UCGR
3	Voice Line Transmission Characteristics & CO Switching	Loop Start, DTMF, & Out-Only (Originate Only)	UCGU
4	Voice Trunk Transmission Characteristics & CO Switching	Ground Start, DTMF, & 2-Way	UDGG
5	Voice Trunk Transmission Characteristics & CO Switching	Ground Start, DTMF & In-Only (Terminate Only)	UDGS
6	Voice Trunk Transmission Characteristics & CO Switching	Ground Start, DTMF & Out-Only (Originate Only)	UDGV

Basic DSS meets the parameters detailed in PUB 77311 *Analog Channel for Non-Access Service* for Voice Grade (VG) 32 and VG 33 Services for loop start and ground start signaling.

5.2.2 When Ordering ISDN SLS with Basic DSS

ISDN SLS can be ordered on the spare channels with Basic DSS only. This service consists of two B and one D channels and occupies 3 DS0 channels that are preferred to be consecutive.

Table 5-3 Code for Ordering ISDN (SLS) with Basic DSS

Network Channel Code	Description
UB - -	ISDN

5.2.3 When Ordering Advanced DSS

The customer shall select the following options for Advanced DSS.

- Supervisory Signaling - two choices
 1. Loop Reverse Battery Signaling. This is used for Direct Inward Dial (DID) Trunks or for Direct Outward Dial (DOD) Trunks with Answer Supervision
 2. E & M signaling, for two-way call origination. E & M Signaling also includes “Wink Start” signaling.
- Trunk (Channel) Types - five choices
 1. In-Only DID Trunk. Calls originate from the switch into the customer’s terminal using loop reverse-battery signaling.
 2. Out-Only DOD Trunk with Answer Supervision. Calls originate from the customer’s terminal into the switch using loop reverse-battery signaling.
 3. Two-Way DID Trunk with Answer Supervision. Calls may originate from either the switch or the customer’s terminal using E & M signaling.
 4. Two-Way DID Trunk with Answer Supervision and Trunk-Side Call Transfer. This option also uses E & M signaling.
 5. Two-Way Digital Data Trunk. This option is also called SwitchNet 56® Service and meets the technical parameters detailed in PUB 77329.

Answer Supervision is offered with Advanced Out-Only DOD or Two-Way DID Trunks only. This unique trunking arrangement provides answer back switch signaling that determines when a PBX call has been answered or completed. Answer supervision capability allows the called switch to originate the answer signal, indicated by an off-hook, after detecting an answer by the called station. Answer Supervision originates at the called or terminating switch and is sent toward the originating switch.

To order the lower channels or trunks for Advanced DSS, refer to Table 5-3. In column A, locate the row having the required technical performance or features of the requested channel. Obtain from column C the NC for each lower channel.

Table 5-4 Codes for Ordering Advanced DSS Trunks

	A	B	C
	Voice Grade Channel Service	Technical Performance	NC Code
1	Advanced Trunk	Direct Inward Dial (DID) Trunk	UDGT
2	Advanced Trunk	Direct Outward Dial (DOD) Trunk with Answer Supervision	UDGY
3	Advanced Trunk	2-Way DID/DOD Trunk with Answer Supervision	UDGM

The Advanced DSS meets the parameters detailed in U S WEST Technical Publication 77311 *Analog Channel for Non-Access Service* for VG 32 and VG 33 Services.

The customer may also choose the type of trunk selection algorithm or hunt on their Advanced DSS circuits to search for available trunks. The term *hunt* is used to describe the automatic process by which a switch progressed through trunk group(s) usually seeking an idle trunk. Table 5-4 summarizes the trunk selection algorithms available with Advanced DSS. The terminology varies depending on the switch type. It is advisable for customers to know the switch type that provides their Advanced DSS in order to select the appropriate hunt.

Table 5-5 Trunk Selection Algorithms for Advanced DSS

	Advanced DSS Option	Lucent Technologies 5ESS Digital Switch	Nortel DMS Digital Switch	Lucent Technologies 1AESS Analog Switch
1	One-Way DID or DOD Trunk (One Choice)	FIFO: First-In, First-out.	LIDL: Least Idle	Regular (similar to FIFO)
2	Two-Way DID Trunk	2WF: Two-Way Forward	ASEQ: Ascending Sequential	Forward Hunt
		2WB: Two-Way Backward	DSEQ: Descending Sequential	Backward Hunt
		UCD: Uniform Call Distribution	MIDL: Most Idle	

Customer may order trunk side Call Transfer feature with Two-way Advanced DSS. The feature allows a PBX customer to send a switch hook flash back to the Central Office and draw dial tone. This enables customer to transfer the incoming call to another number and free up the Advanced trunk for more incoming calls.

Trunk-Side Call Transfer feature is only available out of 1AESS analog switches and 5ESS digital switches.

CONTENTS

Chapter and Section	Page
6. Compatible NC and NCI Code Combinations for features of DSS.....	6-1
6.1 DSS with Self Healing Alternate Route Protection (SHARP).....	6-1
6.1.1 Order the High Capacity Channel.....	6-1
6.1.2 Order the Lower Channel	6-2
6.2 DSS Assigned to DS3 Service.....	6-2
6.3 Advanced DSS with Two-Way Digital Data Trunk.....	6-2
6.3.1 Ordering the DS1 Channel.....	6-3
6.3.2 Order Advanced DSS.....	6-3
6.3.2 Order the Two-Way Digital Data Trunk.....	6-3

Tables

6-1 Codes for Ordering DSS with SHARP	6-1
6-2 Codes for Ordering DSS with DS3.....	6-2
6-2 Codes for Ordering Advanced DSS with Two-Way Digital Data Trunk	6-3

6. Compatible NC and NCI Code Combinations for Features of DSS

6.1 DSS with Self Healing Alternate Route Protection (SHARP)

Digital Switched Service (DSS) may be ordered with Self-Healing Alternate Route Protection (SHARP) Service or SHARP Plus Service limited to Intrastate Jurisdiction for customer survivability and disaster recovery loop protection. SHARP is provisioned over fiber facilities.

6.1.1 Order the High Capacity Channel

To order DSS with SHARP or SHARP Plus Service, refer to Table 6-1. In column A, locate the row having the required technical performance or features of the requested channel. Obtain the NC code from column C. Obtain the NCI code from column D.

Table 6-1: Codes for Ordering DSS with SHARP

	A	B	C	D
	Equipment Frame Format and Line Code	Other Options	NC Code	NCI at End-User Premises
1	SF & AMI	DS1 with Self-Healing and Disaster Recovery Loop Protection (One End Only); Includes Voice and Digital Data Multiplexing; Also known as SHARP Service	HCHC	04DU9.BN
2	ANSI ESF & AMI	Same as Row 1, Column B	HCHC	04DU9.KN
3	Non-ANSI ESF & AMI	Same as Row 1, Column B	HCHC	04DU9.CN
4	SF & AMI	DS1 with Self-Healing and Disaster Recovery Loop and Interoffice Facilities Protection; Includes Voice and Digital Data Multiplexing; Also known as SHARP Plus Service	HCHS	04DU9.BN
5	ANSI ESF & AMI	Same as Row 4, Column B	HCHS	04DU9.KN
6	Non-ANSI ESF & AMI	Same as Row 4, Column B	HCHS	04DU9.CN

6.1.2 Order the Lower Channels

Refer to Table 5-2 and 5-3 to obtain the NC codes for ordering Basic or Advanced DSS respectively.

6.2 DSS Assigned to DS3 Service

The customer may assign DSS to DS3 Service, which tariffed under Interstate jurisdiction FCC No. 5.

To order DSS embedded within a DS3, refer to Table 6-1. In column A, locate the row having the required technical performance or features of the requested channel. Obtain the NC code from column C. Obtain the NCI code from column D.

Table 6-2 Codes for Ordering DSS with DS3 Service

	A	B	C	D
	Equipment Frame Format and Line Code	Other Options	NC Code	NCI at End-User Premises
1	M Framed & B3ZS	DS3 signal with M23 CO Multiplexing	HC-M	04DS6.44
2	M Framed & B3ZS	DS3 signal with M23 CO Multiplexing; Optioned for DS1 Clear Channel Capability	HC-1	04DS6.44
3	M Framed & B3ZS	DS3 with SHARP: Loop Protection (One End Only) and CO Multiplexing	HFHM	04DS6.44
4	M Framed & B3ZS	DS3 with SHARP Plus: Loop and Interoffice Facilities Protection and CO Multiplexing	HFHJ	04DS6.44

6.2.1 Order the Lower Channels

Refer to Table 5-2 and 5-3 to obtain the NC codes for ordering Basic or Advanced DSS respectively.

6.3 Advanced DSS with Two-Way Digital Data Trunk

In choosing the Advanced DSS, customers may allocate a portion of the trunks to be Two-Way Digital Data Trunk. This service option is identical to QWEST SwitchNet 56® Service and tariffed in FCC #5.

SwitchNet 56® Service is a high speed digital transport which provides end-to-end 56 kilobit per second (56 kbit/s) switched digital connectivity. It comprises those features needed to link Customer Provided Equipment (CPE) to switching systems and digital transmission facilities. SwitchNet 56® has the potential to support many different customer applications, such as, bulk data/file transfer, high speed facsimile, remote job entry, video teleconferencing, simultaneous voice/data, computer graphics, encrypted voice/data and high fidelity voice. Each SwitchNet 56® call provides full duplex two-way transmission. It is only offered over a 4-wire loop. Refer to Technical Publication 77329 *SwitchNet 56® SWITCHED 56 kbit/s DIGITAL SERVICE*.

6.3.1 Order the DS1 Channel

Refer to Section 5.1 and Table 5-1 to order the DS1 channel.

6.3.2 Order Advanced DSS

Refer to Section 5.2.2 and Table 5-3 to order Advanced DSS.

6.3.3 Order the Two-Way Digital Data Trunk

To order the lower channels or trunks assigned as Two-Way Digital Data Trunk, refer to Table 6-3. In column A, locate the row having the required technical performance or features of the requested channel. Obtain from column C the NC for each lower channel.

Table 6-2 Codes for Ordering Advanced DSS with Two-Way Digital Data Trunk

	A	B	C
	Switched Access Line Transmission Type B	Technical Performance	NC Code
1	Foreign Exchange 4-Wire Interface	FGA, DTMF-Ground Start, Two-Way	SDGG

CONTENTS

Chapter and Sections

7.	Definitions.....	7-1
7.1	Acronyms.....	7-1
7.2	Glossary	7-2

7. Definitions

7.1 Acronyms

ACD	Automatic Call Distributor
AMI	Alternate Mark Inversion
ANSI	American National Standards Institute
AWC	Alternate Wire Center
CFA	Connecting Facility Assignment
CPE	Customer Provided Equipment
DID	Direct Inward Dial
DOD	Direct Outward Dial
DSS	Digital Switched Service
EML	Expected Measured Loss
ERL	Echo Return Loss
ESF	Extended Superframe
EU	End-User
IC	Interexchange Carrier
ISDN	Integrated Services Digital Network
LEC	Local Exchange Carrier
NC	Network Channel
NCI	Network Channel Interface
NI	Network Interface
PBX	Private Branch Exchange
POP	Point of Presence
POT	Point of Termination
PSTN	Public Switched Telephone Network
SF	Superframe
SHARP	Self-Healing Alternate Route Protection
SHNS	Self-Healing Network Service
SLS	Single Line Service
SRL	Singing Return Loss

SWC Serving Wire Center
TLP Transmission Level Point

7.2 Glossary

Alternate Mark Inversion (AMI)

A line-code for transmission of baseband digital signals wherein a binary one pulse (called a mark) is the opposite polarity as its predecessor.

Answer Supervision

An off-hook signal transmitted towards the calling end of a connection when the called party answers.

Automatic Call Distributor (ACD)

A switching system designed to distribute a large volume of incoming calls to a group of attendants in the approximate order in which the calls were received.

Bipolar Return to Zero (BPRZ)

A three-level code in which a binary 1 is represented by a pulse of one of two polarities, and a binary zero is represented by the absence of a pulse. During the unit interval for a pulse, the signal voltage will rise in amplitude for a portion of the unit interval, possibly be sustained at some amplitude for part of the unit interval, then decrease in time to zero before the end of the unit interval. AMI and B8ZS line-codes are applications of BPRZ.

Central Office (CO)

A general term usually referring to a telephone company building in which telephone equipment is installed. Also used to refer to an end office switching system.

Channel Service Unit (CSU)

Customer owned Network Channel Terminating Equipment, providing regeneration of the signal received from the network, control of the pulse shape and amplitude of the customer signal transmitted into the network. (The CSU may also provide loopback capability). In data applications, the CSU function is usually found within a Data Service Unit. In non-data applications, the CSU functions are sometimes contained within the terminal equipment (PBX, etc.)

Connecting Facility Assignment (CFA)

Identifies the Exchange Company carrier system and channel to be used from a High Capacity Facility.

Customer Provided Equipment (CPE)

Equipment owned and maintained by the customer and located on their side of the EU-POT network interface. In the QWEST Digital Data Service application, CPE typically includes the DSU (CSU/DSU) and data terminal equipment, which are connected to the channel.

Direct Inward Dialing (DID)

A feature of some telephone switches, Centrexes, PBXs, and systems providing similar functions, where calls from the Public Switched Network (PSN) to stations on the PBX (etc.) can be completed without operator assistance.

Direct Inward Dialing (DID) Trunk

A trunk between a QWEST Communications, Inc. Public Switched Network (PSN) switch and a Centrex, PBX, or system providing similar functions, for the completion of DID calls.

Direct Outward Dialing (DOD)

A feature which permits a station on Centrex, PBX, or system providing similar functions, to gain access to the Public Switched Network (PSN) without operator assistance.

Direct Outward Dialing (DOD) Trunk

A trunk between a Centrex, PBX, or system providing similar functions, and a QWEST Communications International Inc. switch for the completion of DOD calls.

DS0 Channel

A rate of 64 kbit/s. Also, a term used to denote one of 24 64 kbit/s channels within a DS1 rate signal.

Dual Tone Multifrequency (DTMF) Signaling

A signaling method that employs signals consisting of two sinusoidal voice frequency components, one from a group of four low frequencies and the other from a group of four high frequencies.

Extended Superframe (ESF) Format

An extended Superframe consists of twenty-four consecutive DS1 frames. Bit one of each frame (the F-bit) is time shared during the 24 frames to describe a 6 bit frame pattern, a 6 bit CRC remainder, and a 12 bit data link. The transfer rate of each is 2 kbit/s, 2 kbit/s, and 4 kbit/s respectively.

E & M Signaling

A bi-directional, full duplex, direct current signaling arrangement between a switching machine and a transport facility, between two switching machines, or between two transport facilities. It uses two or four signaling conductors in addition to the transmission path conductors.

Ground-Start

A form of line supervision where a ground is placed on the ring lead to initiate a call set-up. A loop closure is simultaneously placed across the tip and ring leads.

Integrated Services Digital Network (ISDN)

A network providing or supporting a range of telecommunications services that provides digital connections between End-Users.

Line Side Connection

Denotes a connection of a transmission path to the dial tone side of a switching system.

Loop-Start

A form of line supervision where a resistive short is placed across the tip and ring leads to initiate a call set-up.

Loop Reverse-Battery

A form of supervision where a loop closure (a current path between the tip and ring) is used to initiate call set-up. When the terminating station answers, answer supervision is indicated to the originating end by the reversal of battery and ground on the Tip and Ring leads. This form of signaling is used on one-way trunks.

Multiplex

An equipment unit to multiplex, or do multiplexing: Multiplexing is a technique of modulating (analog) or interleaving (digital) multiple, relatively narrow bandwidth channels into a single channel having a wider bandwidth analog or higher bit-rate (digital). The term Multiplexer implies the demultiplexing function is present to reverse the process so it is not usually stated.

Network Channel (NC) Code

The Network Channel (NC) code is an encoded representation used to identify both switched and non-switched channel services. Included in this code set are customer options associated with individual channel services, or feature groups and other switched services.

Network Channel Interface (NCI) Code

The Network Channel Interface (NCI) code is an encoded representation used to identify five (5) interface elements located at a Point of Termination (POT) at a central office or at the Network Interface at a customer location. The Interface code elements are: Total Conductors, Protocol, Impedance, Protocol Options, and Transmission Level Points (TLP). (At a digital interface, the TLP element of the NCI code is not used).

Network Interface (NI)

The point of demarcation on the end-user's premises at which QWEST's responsibility for the provision of service ends.

Point of Termination (POT)

The physical telecommunications interface that establishes the technical interface, the test point(s), and the point(s) of operational responsibility. (See Network Interface).

Private Branch Exchange (PBX)

A switching system that provides internal telephone communications between stations located on a customer's premises as well as between these stations and exterior networks.

Pulse Code Modulation (PCM)

A type of modulation wherein the waveform of each channel is sampled many times per second in sequence. The amplitude of each sample is then encoded into a binary code and transmitted to the distant end where the pulse train is decoded and distributed to each channel in the exact time sequence to reproduce the original waveform of the channel.

Serving Wire Center (SWC)

The term "Serving Wire Center" denotes a QWEST Communications International Inc. Central Office from which dial tone for the Local Exchange Service would normally be provided to the demarcation point on the property at which the customer is served.

Superframe (SF) Format

A superframe consists of 12 consecutive DS1 frames. Bit one of each frame (the F-bit) is used to describe a 12 bit framing pattern during the 12 frames.

Trunk-Side Connection

Denotes the connection of a transmission path to the non-dial tone side of a local exchange switching system.

CONTENTS

Chapter and Section	Page
8. References.....	8-1
8.1 American National Standards Institute.....	8-1
8.2 QWEST Technical Publication.....	8-1
8.3 Telcordia Documents	8-1
8.4 Other Publications.....	8-2
8.5 Ordering Information	8-2
8.6 Trademarks	8-3

8. References

8.1 American National Standards Institute

ANSI T1.403 -1994 *American National Standard for Telecommunications-Carrier to Customer Installation - DS1 Metallic Interface Specification.*

ANSI T1.223 -1991 *American National Standard for Telecommunications - Information Interchange - Structure and Representation of Network Channel (NC) and Network Channel Interface (NCI) Codes for the North American Telecommunications System.*

8.2 QWEST Technical Publication

Service

PUB 77200 *QWEST DS1 Service and Synchronization Service Publication. Issue F, July 2001.*

PUB 77311 *QWEST Technical Publication, Analog Channels for Non-Access Service. Issue D, July 2001.*

PUB 77324 *QWEST DS3 Service. Issue D, July 2001.*

PUB 77332 *QWEST Self-Healing Network Service (DS1, DS3, OC3 & OC12). Issue L, July 2001.*

PUB 77340 *Self-Healing Alternate Route Protection (SHARP). Issue F, July 2001.*

PUB 77375 *QWEST 1.544 Mbit/s Channels Interfaces Technical Specifications for Network Channel Interface Codes Describing Electrical Interfaces at Customer Premises and at QWEST Communications International Inc. Central Offices. Issue E, July 2001.*

8.3 Telcordia Documents

SR-ST5-000307 *NC/NCI Code Dictionary. Issue 8, April 1997.*

TR-NWT-000397 *ISDN Basic Access Transport System Requirements. Issue 3, December 1993.*

8.4 Other Publications

Part 68 Code of Federal Regulations 47, Part 68

Tariff FCC No. 1 QWEST Communications ACCESS SERVICE (Interstate)

FCC Rules and Regulations, Part 68, may be obtained from the appropriate volumes of the Code of Federal Regulations (CFR).

8.5 Ordering Information

All documents are subject to change and their citation in this document reflects the most current information available at the time of printing. Readers are advised to check status and availability. Those who are not QWEST employees may order;

American National Standards Institute (ANSI) documents from:

American National Standards Institute
Attn: Customer Service
11 West 42nd Street
New York, NY 10036
Phone: (212) 642-4900
Fax: (212) 302-1286

ANSI has a catalog available which describes their publications.

Telcordia documents from:

Telcordia Customer Relations
8 Corporate Place, PYA 3A-184
Piscataway, NJ 08854-4196
Phone: (800) 521-CORE (2673) (U.S. and Canada)
Phone: (908) 699-5800 (Others)
Fax: (908) 336-2559
Web: www.telcordia.com

QWEST Technical Publications from:

<http://www.qwest.com/techpub>

Federal Communications Commission (FCC) documents may be obtained from:

Superintendent of Documents
Government Printing Office
Washington, D. C. 20402
Phone: (202) 783-3283

Employees of QWEST Communications, Inc. may order publications by submitting form RG 31-0033 to:

Central Distribution Center (CDC)
1005 17th St., S-30
Denver, CO 80202
Phone: (303) 896-9446
Fax: (303) 965-8652

Most QWEST publications are available to QWEST employees on the company network (E*Media). Call 303-624-4796 for further information.

8.6 Trademarks

COMMON LANGUAGE Registered Trademark of Telcordia.

NC/NCI Trademark of Telcordia

QWEST Registered Trademark of QWEST Communications International Inc.