

Qwest Corporation Technical Publication

Qwest COMMON CHANNEL SIGNALING (CCS) NETWORK INTERFACE SPECIFICATION (ADDENDUM TO GR-905 AND GR-954)

Copyright 1991, 1992, 1993, 2001, 2002, 2005, 2006
QWEST Corporation
All Rights Reserved

**77342
Issue H
March 2006**

Throughout this publication, the term QWEST signifies QWEST Corporation.

NOTICE

The Telcordia Technical Reference Documents TR-TSV-000905, "Common Channel Signaling (CCS) Network Interface Specification," and TR-TSV-000954, "Common Channel Signaling (CCS) Network Interface Specification Supporting Alternate Billing Services (ABS)," were issued to provide an in depth view of CCS architecture, and lay the foundation for the CCS Interconnection planning of the Telcordia Client Companies.

There are aspects of QWEST Corporation's Network that are not fully covered by the above documents. These elements of the architecture form the basis for this document, QWEST Common Channel Signaling (CCS) Network Interface Specification (Addendum to GR-905 and GR-954).

Many optional parameters will be negotiated, on an individual case basis, during prenegotiation meetings to meet specific customer needs.

QWEST Corporation reserves the right to revise this document for any reason, including but not limited to, conformity with standards promulgated by various governmental or regulatory agencies; utilization of advances in the state of the technical arts; or to reflect changes in the design of equipment, techniques, or procedures described or referred to herein.

Liability to anyone arising out of use or reliance upon any information set forth herein is expressly disclaimed, and no representation or warranties, expressed or implied, are made with respect to the accuracy or utility of any information set forth herein.

This document is not to be construed as a suggestion to any manufacturer to modify or change any of its products, nor does this publication represent any commitment by QWEST Communications International Inc. to purchase any specific products. Further, conformance to this publication does not constitute a guarantee of a given supplier's equipment and/or its associated documentation.

Future issues of Technical Publication 77342 will be announced to the industry at least 45 days prior to the issuance date. This notice, which will come through our standard customer notification channels, will allow the customer time to comment on the proposed revisions.

Ordering information for QWEST Technical Publications can be obtained from the Reference Section of this document.

If further information is required, please contact:

QWEST Corporation
Manager – New Services Planning
700 W Mineral Ave.
Littleton, CO 80120
303-707-7577
Mail: techpubs@qwest.com

Throughout this publication, the term QWEST signifies QWEST Corporation.

COMMENTS on PUB 77342

PLEASE TEAR OUT AND SEND YOUR COMMENTS/SUGGESTIONS TO:

QWEST Corporation
Manager – New Services Planning
700 West Mineral Ave
Littleton, CO 80120
(303) 707-7577
E-Mail: techpubs@qwest.com

Information from you helps us to improve our Publications. Please take a few moments to answer the following questions and return to the above address.

Was this Publication valuable to you in understanding the technical parameters of our service?	YES _____ NO _____
Was the information accurate and up-to-date?	YES _____ NO _____
Was the information easily understood?	YES _____ NO _____
Were the contents logically sequenced?	YES _____ NO _____
Were the tables and figures understandable and helpful	YES _____ NO _____
Were the pages legible?	YES _____ NO _____

If you answered NO to any of the questions and/or if you have any other comments or suggestions, please explain:

(Attach additional sheet, if necessary)

Name _____ Date _____

Company _____

Address _____

Telephone Number _____

E-Mail _____

CONTENTS

Chapter and Section	Page
1. Introduction.....	1-1
1.1 General	1-1
1.2 Reason For Reissue	1-1
1.3 Scope.....	1-1
1.4 Publication Organization	1-2
2. Qwest Corporation (Qwest) Common Channel Signaling Interconnection Requirements	2-1
2.1 Compliance References	2-1
2.2 Physical Level Specifications.....	2-1
2.2.1 Common Channel Signaling (CCS) Network Interconnection Architecture.....	2-1
2.2.1.1 ICN STP to Qwest STP.....	2-2
2.2.1.2 ICN SSP to Qwest STP	2-3
2.2.1.3 ICN SSP TO Qwest FSPOI.....	2-3
2.2.2 Link Transport Architecture.....	2-3
2.2.2.1 Link Architecture	2-3
2.2.2.2 Facility Architecture	2-4
2.2.2.3 Link Diversity.....	2-4
2.2.3 Synchronization.....	2-4
2.2.4 Interconnect Testing	2-4
2.3 Trunk Circuit Identification Codes (TCIC) Number Assignment.....	2-5
2.4 Tones and Announcements.....	2-5
2.5 Data Base Query Requirements.....	2-5
2.6 Transaction Capability Application Part (TCAP) Based Services	2-6
2.6.1 Alternate Billing Service (ABS)/Originating Line Number Screening.....	2-6
2.6.2 Toll Free Data Base (8XX DB).....	2-7
2.6.3 Call Management/Custom Calling Services	2-7
2.6.4 Calling Name Delivery.....	2-7
2.6.5 Local Service Provider Number Portability.....	2-8
2.6.6 Advance Intelligent Network (AIN) Services.....	2-8
2.7 Gateway Screening.....	2-9
2.7.1 Network Management Messages.....	2-10
2.7.2 SCCP Management Fields.....	2-11
2.7.3 SCCP Non-Management Fields	2-11
2.8 Transfer Prohibited (TFP) Procedures.....	2-12

CONTENTS (Continued)

Chapter and Section	Page
3. Network Channel/Network Channel Interface Codes.....	3-1
3.1 Network Channel (NC) Codes.....	3-1
3.1.1 General.....	3-1
3.1.2 Format.....	3-1
3.2 Network Channel Interface (NCI) Codes.....	3-2
3.2.1 General.....	3-2
3.2.2 Format.....	3-2
4. Compatible NC and NCI Code Combinations.....	4-1
4.1 Network Channel (NC) and Network Channel Interface (NCI) Codes.....	4-1
4.2 CCS Network Interface (NI) Link Configurations.....	4-4
4.3 Network Channel (NC) and Network Channel Interface (NCI) Code Sets.....	4-4
4.3.1 Network Channel (NC) Codes.....	4-4
4.3.2 Network Channel Interface (NCI) Codes.....	4-5
5. Definitions.....	5-1
5.1 Acronyms.....	5-1
5.2 Glossary.....	5-2
6. References.....	6-1
6.1 American National Standards Institute Documents.....	6-1
6.2 Telcordia Documents.....	6-1
6.3 Qwest Technical Publications.....	6-3
6.4 Other Publications.....	6-3
6.5 Ordering Information.....	6-3
6.6 Trademarks.....	6-4

CONTENTS (Continued)

Figures	Page
2-1 CCS Network Interconnection Architecture	2-2
3-1 Format Structure for NC Codes	3-1
3-2 Format Structure for NCI Codes.....	3-2
4-1 Qwest STP equipped with a DS0-A Port.....	4-4

Tables	
2-1 Translation Type Code Table.....	2-6
2-2 Qwest Gateway STP Screening - MTP Fields	2-9
2-3 Network Management Messages Supported by Qwest.....	2-10
2-4 Network Management Messages Not Supported by Qwest.....	2-11
2-5 Qwest Gateway STP Screening - SCCP Management Fields.....	2-11
2-6 Qwest Gateway STP Screening - SCCP Non-Management Fields.....	2-11
3-1 NCI Impedance Values.....	3-3
4-1 Permissible NCI Codes.....	4-2
4-2 NC and NCI Combinations for Inter-LATA Access Service	4-3
4-3 NC and NCI Combinations for Intra-LATA Access Service	4-3
4-4 NC Codes.....	4-5
4-5 NCI Codes and related Interface Groups FG D and CST with SS7.....	4-6

CONTENTS

Chapter and Section	Page
1. Introduction.....	1-1
1.1 General	1-1
1.2 Reason For Reissue	1-1
1.3 Scope.....	1-1
1.4 Publication Organization	1-2

1.1 General

Technical Publication 77342 *Qwest Common Channel Signaling (CCS) Network Interface Specification* provides InterConnecting Networks (ICNs) with the compatibility information required for interconnecting with the Qwest Corporation (Qwest) Network.

The Telcordia Generic Requirements (GR), GR-905 "Common Channel Signaling (CCSNIS) Network Interface Specification, Message Transfer Part (MTP) and Integrated Services Digital Network User Part (ISDNUP)," GR-954 "Common Channel Signaling (CCS) Network Interface Specification (CCSNIS) Supporting Line Information Database (LIDB) Service," were issued to provide an in depth view of CCS architecture, and lay the foundation for the CCS Interconnection planning of the Telcordia Client Companies.

There are aspects of Qwest's Local Network that are not fully covered by the above documents. These elements of the architecture form the basis for this document, Qwest Common Channel Signaling (CCS) Network Interface Specification (Addendum to GR-905 and GR-954). *Many optional parameters will be negotiated, on an individual case basis, during prenegotiation meetings to meet specific customer needs.*

1.2 Reason for Reissue

This publication is being reissued to:

- Clarified Intermediate Global Title query message routing requirement.
-

1.3 Scope

This document, in conjunction with Telcordia Generic Requirements GR-905 and GR-954 provides InterConnecting Networks (ICNs) with the compatibility information required for interconnecting with the Qwest Local Network. This document also contains the interconnection specifications that are considered optional in Telcordia GR-905 and GR-954 and may be negotiated with the ICNs during standard prenegotiation meetings.

The publication also provides the Network Channel (NC) and Network Channel Interface (NCI) codes and their definitions associated with interconnecting with Qwest's network.

1.4 Publication Organization

- Chapter 1 **Introduction**, provides the purpose and general information about this document.
- Chapter 2 **Overview of Qwest Common Channel Signaling (CCS) Network Interface Specifications**, describes the CCS network and its requirements.
- Chapter 3 **Network Channel and Network Channel Interface Codes**, provide a general explanation of the codes.
- Chapter 4 **Compatible NC and NCI Code Combinations**, illustrates compatible NC and NCI code combination tables for ordering the services described in the chapter.
- Chapter 5 **Definitions and Acronyms**
- Chapter 6 **References**

CONTENTS

Chapter and Section	Page
2. Qwest Corporation (Qwest) Common Channel Signaling Interconnection Requirements	2-1
2.1 Compliance References	2-1
2.2 Physical Level Specifications.....	2-1
2.2.1 Common Channel Signaling (CCS) Network Interconnection Architecture.....	2-1
2.2.1.1 ICN STP to Qwest STP.....	2-2
2.2.1.2 ICN SSP to Qwest STP.....	2-3
2.2.1.3 ICN SSP TO Qwest FSPOI.....	2-3
2.2.2 Link Transport Architecture.....	2-3
2.2.2.1 Link Architecture	2-3
2.2.2.2 Facility Architecture	2-4
2.2.2.3 Link Diversity.....	2-4
2.2.3 Synchronization Plan.....	2-4
2.2.4 Interconnect Testing	2-4
2.3 Trunk Circuit Identification Codes (TCIC) Number Assignment.....	2-5
2.4 Tones and Announcements.....	2-5
2.5 Data Base Query Requirements.....	2-5
2.6 Transaction Capability Application Part (TCAP) Based Services	2-6
2.6.1 Alternate Billing Service (ABS)/Originating Line Number Screening.....	2-6
2.6.2 Toll Free Data Base (8XX DB).....	2-7
2.6.3 Call Management/Custom Calling Services	2-7
2.6.4 Calling Name Delivery	2-7
2.6.5 Local Service Provider Number Portability.....	2-8
2.6.6 Advance Intelligent Network (AIN) Services.....	2-8
2.7 Gateway Screening.....	2-9
2.7.1 Network Management Messages.....	2-10
2.7.2 SCCP Management Fields.....	2-11
2.7.3 SCCP Non-Management Fields	2-11
2.8 Transfer Prohibited (TFP) Procedures.....	2-12

CONTENTS (Continued)

Figures	Page
2-1 CCS Network Interconnection Architecture	2-2

Tables	
2-1 Translation Type Code Table.....	2-6
2-2 Qwest Gateway STP Screening - MTP Fields	2-9
2-3 Network Management Messages Supported by Qwest.....	2-10
2-4 Network Management Messages Not Supported by Qwest.....	2-11
2-5 Qwest Gateway STP Screening - SCCP Management Fields.....	2-11
2-6 Qwest Gateway STP Screening - SCCP Non-Management Fields.....	2-11

2. Qwest Corporation (Qwest) Common Channel Signaling Interconnection Requirements

This chapter provides an overview of the Common Channel Signaling (CCS) interconnection requirements to Qwest signaling network. It also discusses compliance, operations, measurements and specific Intelligent and Advanced Intelligent message requirements.

2.1 Compliance References

Qwest uses the references listed in Chapter 6 as the foundation for CCS/SS7 interconnection requirements. The related industry standards for vendor compliance are also included in Chapter 6.

Specific requirements may be negotiated between Qwest and the InterConnecting Network (ICN) at the time of interconnection.

2.2 Physical Level Specifications

2.2.1 Common Channel Signaling (CCS) Network Interconnection Architecture

Interconnection to the Qwest Common Channel Signaling (CCS) Network is available to Interexchange Carriers (ICs), Independent Exchange Carriers, Enhanced Service Providers and End-Users (EU's) for interconnection to their CCS network.

Two basic CCS network interconnection arrangements will be supported to Qwest's STP pairs. These include Diagonal ("D") or Bridge ("B") link sets from an ICN STP and Access ("A") link sets from an ICN SSP. As illustrated in Figure 2-1, interconnecting STPs are deployed as geographically separated mated pairs to protect against simultaneous failure and to meet the availability objective for a CCS Network.

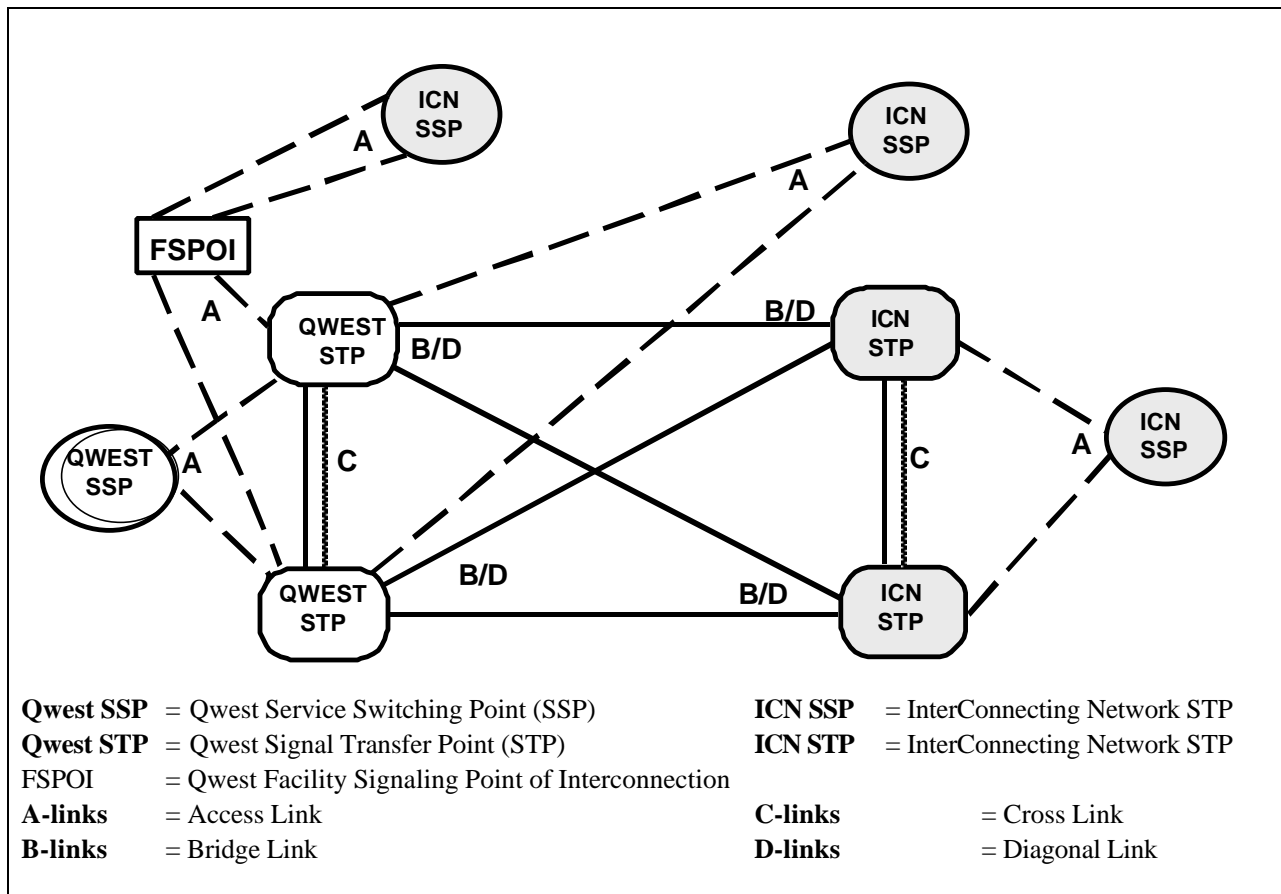

Figure 2-1 CCS Network Interconnection Architecture

Qwest requires all requests for signaling connectivity from new signaling nodes (i.e. node types that do not have current connectivity to the Qwest signaling network) be accompanied by an independent third-party assessment of the new node's compliance with Telcordia GR-905, *Common Channel Signaling Network Interface Specification (CCSNIS) Supporting Network Interconnection, Message Transfer Part (MTP), and Integrated Services Digital Network User Part (ISDNUP)*. The node vendor's own assessment is not acceptable. In all cases, Qwest reserves the right to isolate the Qwest network from any node if detrimental impacts to the signaling network occur.

2.2.1.1 ICN STP to Qwest STP

Qwest will support CCS network interconnection via B/D-link set quads from ICN STP pairs. In this configuration, the ICN mated STP pair is interconnected to the Qwest mated STP pair by way of quad "D" links. A minimum of three physically diverse, link facility routes are strongly recommended. Qwest will effectuate and maintain link diversity from the geographically separated Qwest STPs to the ICN SPOI per a joint agreement.

2.2.1.2 ICN SSP to Qwest STP

Qwest will support CCS network interconnection via A-link set pairs directly from an ICN SSP. In this configuration, each directly subtending ICN SSP is interconnected to the Qwest mated STP pair by two "A" link sets. The A-links are installed in pairs from the ICN SSP with a minimum of one link per link set to each STP pair. Link sets will be grown for capacity purposes in multiples of 1, 2, 4, 8 or 16 links per link set. The "A" links must be on physically diverse link facility routes in order to meet network reliability specifications in Telcordia GR-246 (see Reference Section). Qwest shall make reasonable effort to effectuate and maintain link diversity from the geographically separated Qwest STP to the ICN SPOI(s) per a joint agreement. The ability to meet network reliability objectives will be jeopardized if "A" link facility routes are not physically diverse. Initial sizing and capacity monitoring will be the responsibility of the ICN.

2.2.1.3 ICN SSP to Qwest Facility Signaling Point of Interconnection (FSPOI)

Qwest will support CCS network interconnection via A-link set pairs directly from an ICN SSP. In this configuration, each directly subtending ICN SSP is interconnected to the Qwest mated FSPOI pair by two "A" link sets. The A-links are installed in pairs from the ICN SSP with a minimum of one link per link set to each STP pair. Link sets will be grown for capacity purposes in multiples of 1, 2, 4, 8 or 16 links per link set. The "A" links must be on physically diverse link facility routes in order to meet network reliability specifications in Telcordia GR-246 (see Reference Section). Qwest shall make reasonable effort to effectuate and maintain link diversity from the geographically separated Qwest FSPOI to the ICN SPOI(s) per a joint agreement. The ability to meet network reliability objectives will be jeopardized if "A" link facility routes are not physically diverse. Initial sizing and capacity monitoring will be the responsibility of the ICN.

FSPOIs provide access to a single LATA and diverse signaling routes will be maintained to the serving STP pair. Customers requiring a greater level of diversity must connect at the serving STP pair.

2.2.2 Link Transport Architecture

2.2.2.1 Link Architecture

Each CCS signaling link must provide digital bi-directional transmission. Each full duplex-signaling link shall operate at the 56 kbit/s data rate and occupy a single DS0 (64 kbit/s) channel of a 24-channel DS1 digital transmission system. The DS0-A channels (signaling data links) are multiplexed into a DS1 format for hand-off at the Network Interface (NI); the point of interconnect between the Qwest's CCS/SS7 Network and the ICN.

2.2.2.2 Facility Architecture

A synchronized DS1 (1.544 Mbit/s rate) terrestrial digital facility is required. The facility must be channelized and comply with the requirements given in Telcordia GR-342, *High-Capacity Digital Special Access Service - Transmission Parameter Limits and Interface Combinations*.

The following aspects apply with respect to the supporting DS1 facility:

- For 56 kbit/s, the DS1 facility does not require Clear Channel Capability (CCC) and may have robbed-bit signaling.
- DS1 Extended Superframe (ESF) format is *strongly* recommended.
- DS1 Superframe (SF) may be used, but is not recommended.
- Refer to Section 4.1 for additional information on frame formats.

2.2.2.3 Link Diversity

Physical and electrical Common Channel Signaling (CCS) link diversity is necessary to achieve the Signaling Point (SP) to SP availability objective specified in Section 7 of Telcordia GR- 905-CORE (see Reference Section). ICN carriers should make all reasonable efforts to establish and maintain signaling link diversity.

2.2.3 Synchronization Plan

Synchronization of CCS networks to achieve established performance objectives, requires the application of *The Digital Synchronization Network Plan* described in Telcordia GR-436, *Digital Synchronization Network Plan*.

This plan advocates the establishment of a single master timing supply per administrative building known as a Building Integrated Timing Supply (BITS). The timing for BITS that supplies clocking for CCS networks, must be traceable to a Primary Reference Source (PRS) as described in American National Standard Institute (ANSI) document ANSI T1.101-1999, *Synchronization Interface Standards*.

2.2.4 Interconnect Testing

Qwest requires testing to be conducted with all ICN's in the initial LATA where they interconnect. The *Network Operations Forum (NOF) Installation and Maintenance Responsibilities SS7 Link and Trunk Installation and Maintenance Access Services document is the basis for compatibility testing*. Qwest prefers to run these tests once per hardware configuration.

Interconnection in subsequent LATAs will require testing based on the ICN's network configuration, equipment and switch software and must be negotiated with the Qwest Network Organization. Lab switches are prohibited from connecting to Qwest's live network.

All other interconnection testing must be negotiated through the Qwest Network Organization.

2.3 Trunk Circuit Identification Codes (TCIC) Number Assignment

Qwest supports the NOF plan for TCIC assignments. These assignments will not be duplicated on groups between the same point codes. TCIC numbers will be determined and initiated by the Inter Connecting Carrier and accepted by Qwest.

Any further administrative needs for assignment of TCIC's will be negotiated with Qwest.

2.4 Tones and Announcements

SS7 Link and Trunk Installations and Maintenance Access Services - Attachment HSS7 Cause Code and Tones & Announcements NIIF Reference Document provides release cause values and treatments.

2.5 Data Base Query Requirements

All query messages should have the routing indicator set for further Global Title Translations (GTT's). Qwest will perform the final GTT.

When a transit network (i.e., Hub provider) loses access to a remote network, signaling route management messages should be sent by the transit network. Verbal notification is also required at this time. The notification should include the time when network access was lost and when it was restored.

Qwest will share the following network information with the ICN accessing Qwest's Service Control Point (SCP) Data Base.

- Point codes, including alias point codes, of all Qwest Regional Signaling Transfer Points (STPs)
- Point codes of Qwest SCP's.
- SubSystem Number (SSN) of Qwest's SCP applications
- Physical points of interconnection
- Signaling Link Codes (SLC's) for each interconnecting link
- Identity of interconnecting link sets
- Primary and alternate routes for all Qwest Regional STP's.

The remote network must share the following information with Qwest:

- Point codes of all interconnecting STP's
- Point codes for STPs performing next-to-final intermediate GTT's
- Point codes of all Service Switching Points (SSP's) originating queries to Qwest
- SubSystem Number (SSN) of the SSP subsystem processing queries
- Primary and alternate routes for remote network's interconnecting STPs

2.6 Transaction Capabilities Application Part (TCAP) Based Services

Qwest offers several services that utilize the TCAP of the SS7 protocol. The TCAP requires the use of the SCCP layer of the SS7 protocol, which provides specialized routing capabilities. One of the SCCP parameters is the Global Title Indicator, which includes a Translation Type (TT), used to direct the message to the appropriate GTT function and, in some cases, to provide the context under which the Global Title digits are to be interpreted. The following table and subsections describe the services that Qwest will be providing and the TT value that Qwest will require from interconnecting networks for these services or capabilities.

All TCAP responses for services shall be returned over the same routing path as the query was sent. ISUP signaling shall be received on the same routing path as it was transmitted. When Qwest, pursuant to a service order, arranges to establish a route to a signaling point, such route to the other signaling point or other signaling network will be used by all signaling points within, and connected to the Qwest signaling network pursuant to the standard requirements of the SS7 protocol. Disputes concerning the association of a signaling point among specific link sets associated with a Qwest mated STP pair will be resolved by consultation with the signaling point owner, as defined in the LERG, Section 1, assignment of SPC. Qwest reserves the right to modify its network pursuant to specifications that may become necessary to meet prevailing demands. All such changes shall be announced in advance and coordinated.

All query messages destined for a Qwest database require a routing indicator to be set for Intermediate Global Title Translations (IGTTs). Qwest performs the final GTT. Do not send queries to Qwest which are destined for another company's database unless Qwest is your hub provider.

Table 2-1 Translation Type Code Table

Service	Translation Type Code
800 Data Base	254
Advance Intelligent Services	247
Alternate Billing Services / OLNS	253
Call Management/ CLASS / Custom Calling Services	251
Calling Name Delivery	5
Local Service Provider Number Portability	11

2.6.1 Alternate Billing Service (ABS) / Originating Line Number Screening (OLNS)

ABS is the offering of Calling Card, Collect and Third Number Billing validation services, via access to a data base. Interconnection with other SS7 networks provides access to each other's databases for this validation service.

Originating Line Number Screening (OLNS) provides the ability to return specific stored data on the Calling Party line.

Qwest supports the sending and receipt of the TT value of 253 for ABS or OLNS. The TT value of 2 will also be considered, but only under a bilateral agreement.

2.6.2 800 Data Base (8XX DB)

This service provides the capability to route 8XX calls via the carrier indicated on the Service Management System (SMS) 8XX-customer record through the use of a Qwest owned database. The data base stores carrier information for each 10 digit 8XX number. When an 8XX service call is recognized by the SSP, call progress is halted and a query is launched to the database. When the database responds with the required call handling instruction, the SSP/8XX office routes the call based on these instructions.

Networks interconnecting to Qwest CCS Network for the purpose of accessing Qwest's 8XX Database are required to use the TT value of 254.

2.6.3 Call Management/Custom Calling Services

Qwest has deployed custom calling services using SS7 network capabilities. These services are variously known as CLASSSM, Call Management Services or Custom Calling Services.

The TCAP based, switch-to-switch, non-Integrated Services Digital Network (ISDN) Call Management features being deployed by Qwest are Telcordia-defined Automatic Call Back, Automatic Recall, and the Screen List Editing capabilities that support Selective Call Rejection, Selective Call Acceptance, Selective Call Forwarding, and Distinctive Ringing/Call Waiting.

Companies requesting CLASS services must provide Qwest with a unique, specific CLASS alias for each Qwest LATA/Multi-LATA service area(s) to facilitate a symmetrical routing path as indicated in Section 2.6.

Interconnection with Qwest's Local Network for the above-mentioned switch-to-switch Call Management applications will require the use of the TT value 251.

2.6.4 Calling Name Delivery

Calling Name Delivery is a feature offered, in conjunction with Caller ID, that delivers the calling party's name, the date and the time of the call, to the called party's premise equipment during the first long silent interval of the ringing cycle. The CNAM service can be utilized only when both the originating and terminating switches are CCS/SS7-capable, when signaling for the call has preserved the originating CCS/SS7 information, and when the terminating central office is equipped with the CNAM feature. The name information is stored in a centralized database and retrieved by the Calling Name subscriber's central office via TCAP signaling messages. For non-Qwest customer data, Qwest may return a locality response.

Qwest requires networks interconnecting for the purpose of querying the Qwest Calling Name database to use the TT value of 5.

2.6.5 Local Service Provider Number Portability

Qwest supports Local Service Provider Portability (LSPP) and Local Number Portability (LNP) which allows local exchange subscribers to change their service provider, physical location and/or service type within a defined geographic LNP area, without having to change their geographic telephone numbers.

Detailed switch requirements for supporting call setup in an LNP environment are provided in the T1S1.6 Working Group on Number Portability Technical Requirements No. 2, *Number Portability Switching Systems*. Detailed Service Control Point (SCP) and Number Portability (NP) Global Title Translation (GTT) function requirements are presented in the T1S1.6 Working Group on Number Portability Technical Requirements No. 3, *Number Portability Database and Global Title Translation*.

If the ICN switch is not LNP-capable and cannot, therefore, launch a query to an LNP database, the ICN switch is expected to proceed with call setup. Qwest will query the call if required.

If the ICN switch that originates the call is an LNP-capable SSP, it may launch an LNP query to Qwest's network before setting up the LNP call. The query to Qwest's LNP database should follow the requirements in Section 5.1.1.1 of the T1S1.6 Technical Requirements No. 2, *Number Portability Switching Systems*. ICNs that query the Qwest LNP database are required to use a TT 11 (for internetwork AIN-based LNP queries).

When the ICN determines a call should be set up to a Qwest network switch, based on an LNP database response, the ICN SSP should set up the call as described in Section 4.1 of Telcordia GR-905 and Section 5.1.1.2.1 of T1S1.6 Technical Requirements No. 2.

Specifically for ported numbers, Qwest expects to receive in the IAM, the Location Routing Number (LRN) in the Called Party Number parameter and the dialed digits in the Generic Address Parameter (GAP). For non-ported numbers, Qwest should receive the dialed digits in the Called Party Number parameter. In either case, Qwest expects Bit M of the Forward Call Indicators of the received IAM to be set to "number translated".

If Qwest is a transient network for the call, Qwest will pass this information unchanged in an outgoing IAM.

2.6.6 Advanced Intelligent Network (AIN) Services

The Advanced Intelligent Network (AIN) is a service independent architecture that is designed to be programmable. AIN is controlled by software distributed in elements throughout the network rather than being translated in the originating or terminating switching offices.

Qwest requires a minimum of AIN 0.1 functionality as indicated in Telcordia GR-1298, *AINGR: Switching Systems*.

Qwest will require networks interconnecting for the purpose of querying the Qwest AIN SCP to use the Translation Type (TT) value of 247 only.

2.7 Gateway Screening

Qwest will perform screening for values in MTP, SCCP Management and SCCP Non-Management fields.

Table 2-2: Qwest Gateway STP Screening - MTP Fields

Screened MTP Message Fields	
Screened Field or Attribute	Allowable Values
Screening Link Set	LSSN
Originating Point Code (OPC)	Screen all valid OPC's
Destination Point Code (DPC)	screening valid to Qwest Communications, Inc. or third-party network signaling points for which traffic arriving from the OPC shall be allowed to route per agreements
Service Indicator Levels 0 to 7, 13 and 14	0 - MPT - NM 1 - MTP - T&M 2 - MTP - T&M (SLTM/SLTA) 3 - SCCP 5 - ISUP
Priority Level 0 to 3	0 - ISUP and SCCP 1 - ISUP 2 - Test and Maintenance 3 - MTP - NM

2.7.1 Network Management Messages

The following messages as defined in Telcordia GR-246, if received, will be screened for entrance into the network.

Table 2-3: Network Management Messages Supported by Qwest

CBA	Changeback Acknowledgment message
CBD	Changeback Declaration message
COA	Changeover Acknowledgment message
COO	Changeover Order message
ECA	Emergency Changeover Acknowledgment message
ECO	Emergency Changeover Order message
LFU	Link Forced Uninhibit message
LIA	Link Inhibit Acknowledgment message
LID	Link Inhibit Denial message
LIN	Link Inhibit message
LLI	Link Local Inhibit Test message (AS 51, 52, 61 and 62 only)
LRI	Link Remote Inhibit Test message (AS 51, 52, 61 and 62 only)
LUA	Link Uninhibited Acknowledgment message
LUN	Link Uninhibited message
* RCP	Signaling Route Set Test Cluster Prohibited message
* RCR	Signaling Route Set Test Cluster Restricted message
* RCT	Signaling Route Set Congestion Test message
* TCA	Transfer Cluster Allowed message
* TCP	Transfer Cluster Prohibited message
* TCR	Transfer Cluster Restricted message
RSP	Signaling Route Set Test Prohibited message
RSR	Signaling Route Set Test Restricted message
TFA	Transfer Allowed message
TFC	Transfer Controlled message
TFP	Transfer Prohibited message
TFR	Transfer Restricted message

*Not Available - Qwest will update as required.

Table 2-6 Identifies the network messages defined in GR-246 that Qwest does not generate and does not expect to receive them from interconnecting networks.

Table 2-4: Network Management Messages Not Supported by Qwest

Abbreviation	Network Management Message
CNP	Connection Not Possible message
CNS	Connection Not Successful message
CSS	Connection Successful message
DLC	Signaling Data Link Connection Order message

2.7.2 SCCP Management Fields

The following SCCP Management fields will be screened for all arriving internetwork messages as summarized in Table 2-5. There are three types of messages: Query, Response, and Management.

Table 2-5: Qwest Gateway STP Screening - SCCP Management Fields

Screened Field or Attribute	Required	Table Driven
SCCP network management point code	Y	Y
Screening Link Set	Y	Y
SCCP network management point codes	Y	Y
SCCP network management messages SSA - SSP - SST	Y	Messages that relate to SCCP Network Management point codes
Affected point code	Y	Y
Affected sub system number	Y	Y

2.7.3 SCCP Non-Management Fields

Table 2-6: Qwest Gateway STP Screening - SCCP Non-Management Fields

Screened Field or Attribute	Required	Table Driven
Originating point code	Y	Y
Sub system number	Y	Y
Local sub system number	NA - Qwest will update as needed	
Screen Link set	Y	Y
Global title translation type	Y	Y
Destination point code	Y	Y
Sub system number	NA - Qwest will update as needed	
Local sub system number	NA - Qwest will update as needed	

2.8 Transfer Prohibited (TFP) Procedures

The Transfer Prohibited (TFP) procedure is performed at a signaling point acting as an STP for messages relating to a given destination, when it has to notify one or more adjacent signaling points that they must no longer route the concerned messages via that STP.

There are two methods, broadcast and response, for sending TFP messages to inform adjacent signaling points about the inaccessibility of a signaling point. In the broadcast method, the STP, recognizing its inability to transfer traffic to a given inaccessible SP, broadcasts TFP's about that SP to all accessible adjacent signaling points. In the response method, the STP only sends a TFP to the adjacent signaling point that sent the message destined to the inaccessible SP. At this time, Qwest gateway STPs use the broadcast method for the sending of TFP's.

CONTENTS

Chapter and Section	Page
3. Network Channel/Network Channel Interface Codes.....	3-1
3.1 Network Channel (NC) Codes.....	3-1
3.1.1 General.....	3-1
3.1.2 Format.....	3-1
3.2 Network Channel Interface (NCI) Codes.....	3-2
3.2.1 General.....	3-2
3.2.2 Format.....	3-2

Figures

3-1 Format Structure for NC Codes.....	3-1
3-2 Format Structure for NCI Codes.....	3-2

Tables

3-1 NCI Impedance Values.....	3-3
-------------------------------	-----

3. Network Channel/Network Channel Interface Codes

3.1 Network Channel (NC) Codes

3.1.1 General

Network Channel (NC) codes are a part of the Telcordia COMMON LANGUAGE® code set. The NC code is used to identify a channel used with the service. This section identifies the available channels and their NC codes.

3.1.2 Format

A NC code is a four-character code with two data elements:

- Channel Code
- Optional Feature Code

The format is illustrated in Figure 3-1.

Data Element	Channel Code		Optional Feature Code	
Character Position	1	2	3	4
Character Key	X	X	X or -	X or -

X = Alphanumeric
 - = Hyphen

Figure 3-1 Format Structure for NC Codes

The **Channel Code** (character positions 1 and 2) is a two-character alpha or alphanumeric code that describes the channel service in an abbreviated form. The channel code will frequently, but not always, be specified as the service code of the special service circuits or the transmission grade of the message trunk circuit. The NC channel code field is always filled.

The **Optional Feature Code** (character positions 3 and 4) is a two-character alpha or alphanumeric or hyphen code that represents the option codes available for each channel code. Varying combinations of this code will allow the customer to enhance the technical performance of the requested channel, or to further identify the type of service. It is also used to specify options such as conditioning, effective 4-wire, multiplexing, etc. The NC optional code field is always filled.

Further information about NC Codes may be found in ANSI T1.223-1997, *Information Interchange — Structure and Representation of Network Channel (NC) and Network Channel Interface (NCI) Codes for the North American Telecommunications System*.

3.2 Network Channel Interface (NCI) Codes

3.2.1 General

Network Channel Interface (NCI) codes are a part of the COMMON LANGUAGE® code set. The NCI code is used to identify a network interface of a service in our mechanized systems.

3.2.2 Format

An NCI code is a maximum twelve-character code that consists of five (5) data elements:

- Total Conductors
- Protocol
- Impedance
- Protocol Options
- Transmission Level Point(s) (TLP) - not required for this digital service.

The first three fields are required. The last two are optional. The format is illustrated in Figure 3-2.

Network Channel Interface Code

Total Conductors		Protocol		I m p e d a n c e	D e l i m i t e r	Protocol Options			D e l i m i t e r	TLP Level	
										T r a n s m i t	R e c e i v e
1	2	3	4	5	6	7	8	9	10	11	12
N	N	A	A	X	•	X	X	X	•	X or -	X or -

- A = Alpha
- N = Numeric
- X = Alphanumeric
- = Delimiter (normally a period)
- = Hyphen

Figure 3-2 Format Structure for NCI Codes

Total Conductors (character positions 1 and 2) is a two-character numeric code that represents the total number of physical conductors (e.g., wires or fibers) required at the interface.

Protocol (character position 3 and 4) is a two-character alpha code that defines requirements for the interface regarding signaling/transmission.

Impedance (character position 5) is a one-character alpha or numeric code representing the nominal reference impedance that will terminate the channel for the purpose of evaluating transmission performance. Values are listed in Table 3-1.

Table 3-1 NCI Impedance Values

Impedance in Ohms (Character Position 5)			
Data Value	Code	Data Value	Code
110	0	124	7
150	1	Variable	8
600	2	100	9
900	3 *	Fiber	F
1200	4	Radio	Z
135	5	50 Coaxial	C
75	6	Multi-Impedance	M

* Except for interface code 04DD3, the impedance character 3, when used with a 4-wire voice-frequency path at the POT, denotes a historical customer (IC) provided transmission termination rather than a 900 ohm impedance. Such terminations were provided by customers in accordance with FCC Docket No. 20099 settlement Agreement and by Automatic Transmission Test and Control Circuit used in the previous provisioning process.

Protocol Options (character positions 7, 8, and 9) is a one to three-character alpha, numeric, or alphanumeric code that describes additional features (e.g., bit rate or bandwidth) on the Protocol to be used. It is an optional field that is always left justified.

CONTENTS

Chapter and Section	Page
4. Compatible NC and NCI Code Combinations.....	4-1
4.1 Network Channel (NC) and Network Channel Interface (NCI) Codes	4-1
4.2 CCS Network Interface (NI) Link Configurations.....	4-4
4.3 Network Channel (NC) and Network Channel Interface (NCI) Code Sets.	4-4
4.3.1 Network Channel (NC) Codes.....	4-4
4.3.2 Network Channel Interface (NCI) Codes.....	4-5
Figures	
4-1 Qwest STP equipped with a DS0-A Port.....	4-4
Tables	
4-1 Permissible NCI Codes.....	4-2
4-2 NC and NCI Combinations for Inter-LATA Access Service.....	4-3
4-3 NC and NCI Combinations for Intra-LATA Access Service.....	4-3
4-4 NC Codes.....	4-5
4-5 NCI Codes and related Interface Groups FG D and CST with SS7.....	4-6

4. Compatible NC and NCI Code Combinations

The tables in this chapter provide code combinations for ordering Common Channel Signaling Access Service offering. The Network Channel (NC) and Network Channel Interface (NCI) codes listed in the same row for each table indicate that these codes are compatible and can be interchanged. When the codes are listed in different rows, they are not compatible.

4.1 Network Channel (NC) and Network Channel Interface (NCI) Codes

The interface with the Qwest Common Channel Signaling Network is described by a NC Code and a NI Code for each signaling link termination. This subsection addresses the channel and interface codes that apply specifically to Qwest Common Channel Signaling Service. The customer must specify these codes when ordering service.

Network Interface (NI): The NI between the Qwest Common Channel Signaling Network and the interconnecting CCS network, shall be a channel using the DS0-A format within a DS1 bit stream. The DS0-A signals (channels) are multiplexed into a DS1 signal for transport. Each DS0-A channel carries information for one CCS link. The DS1 bit stream may be multiplexed within a DS3 bit stream.

Network Channel (NC) Codes

The NC code is a four-character code that identifies the channel service, parameters and available feature options.

NC code "YNS -" describes an interLATA (Local Access and Transport Area) CCS access channel, and NC code "US - -" describes an intraLATA CCS access channel.

Network Channel Interface (NCI) Codes

The NCI code identifies interface specifications associated with a particular channel and it provides the means to define the physical and electrical/optical characteristics at the channel interface, thus ensuring compatibility between the NC and the associated ICN SPOI.

A concise description of applicable NCI codes is provided in Table 4-1.

The following definitions, descriptions and reference specifications apply to the specified codes:

- ANSI Extended Superframe (ESF) format refers to the ESF format described in the, ANSI T1.403-1999, "Carrier-to-Customer Installations-DS1 Metallic Interface" or Telcordia GR-342 (see Reference Section).
- ANSI ESF terminal equipment generates a Performance Report at 1-second intervals across the NI, which may be read by terminal equipment monitor units at either end of a DS1 path providing end-to-end performance for both directions of transmission. *Consequently, the ANSI ESF format is strongly recommended.*
- *Non-ANSI ESF* refers to versions prior to ANSI T1.403-1989 standards, hence, it is not fully compatible with the ESF structure described in ANSI T1.403-1999 (see

Reference Section) or Telcordia GR-342 (see Reference Section).

- The significant difference is the Data Link, it is either not used for network messages, or messages used are proprietary, therefore no messages other than a Yellow Alarm during a failure condition will be acknowledged. *Non-ANSI ESF format is not recommended.*
- SF format, described in Telcordia GR-342 (see Reference Section) is permitted but *not recommended* due to severely limited performance monitoring capabilities.
- The B8ZS line code which enables DS1 CCC is not required for CCS interconnect service. These codes were included to accommodate existing or planned facility arrangements.
- Consult T.1.223-1997, "Information Interchange - Structure and Representation of Network Channel (NC) and Network Channel Interface (NCI) Codes for the North American Telecommunications System" or Qwest Technical Publication 77375, "1.544 Mbit/s Channel Interfaces," for additional information and an expanded description.

Table 4-1 Permissible NCI Codes

Definition of Network Channel Interface Code and Protocol Option Code	Qwest CO premises Options	Other Carrier premises Options	End-user premises Options
Free Framing Line code = B8ZS	04DS9.15J	04DJ9.15J 04DS9.15J	04DU9.AN 04DU9.AX
Frame Format = Superframe (SF) Line code = Alternate Mark Inversion (AMI)	04DS9.15	02DJ9.15*** 04DJ9.15 04DS9.15	02DU9.BN*** 04DU9.BN 04DU9.BX
Frame Format = Superframe (SF) Line code = Binary, 8 Zero Substitution (B8ZS)	04DS9.15B	04DJ9.15B 04DS9.15B	04DU9.DN 04DU9.DX
Frame Format = non-ANSI Extended Superframe (ESF) Line code = Alternate Mark Inversion (AMI)	04DS9.15K	04DJ9.15K 04DS9.15K	04DU9.CN 04DU9.CX
Frame Format = non-ANSI Extended Superframe (ESF) Line code = Binary, 8 Zero Substitution (B8ZS)	04DS9.15S	04DJ9.15S 04DS9.15S	04DU9.SN 04DU9.SX
Frame Format = ANSI Extended Superframe (ESF) Line code = Alternate Mark Inversion (AMI)	04DS9.1K	04DJ9.1K 04DS9.1K	04DU9.1KN 04DU9.1KX
Frame Format = ANSI Extended Superframe (ESF) Line code = Binary, 8 Zero Substitution (B8ZS)	04DS9.1S	04DJ9.1S 04DS9.1S	04DU9.1SN 04DU9.1SX

EACH CODE IS COMPATIBLE WITH ITSELF, WITH THE OTHER CODES WITHIN THE SAME BOX,
AND WITH THE CODES IN THE OTHER BOXES IN THE SAME ROW

Note: *** 02DU9.BN and 02DJ9.15 are used only for the Synchronization interface.

DS1 can be included in DS3 transmission rates offered by Qwest. Refer to Qwest

Technical Publication, 77324, *Qwest DS3 Service*, for more information.

Tables 4-2 and 4-3 below summarize permissible NC and NCI code combinations for ordering interLATA or intraLATA CCS access service.

Table 4-2 NC and NCI Combination for Inter-LATA Access Service

NC code: YNS– Digital Access Channel Service (SS7-56 kbit/s Link)			
NCI code at the SPOI			
DS1 ANSI ESF	DS1 Non-ANSI ESF	DS1 SF	DS1 NCI Description
04DJ9.1K	04DJ9.15K	04DJ9.15	Carrier Interface•Joint Designed•AMI
04DJ9.1S	04DJ9.15S	04DJ9.15B	Carrier Interface•Joint Designed•B8ZS
04DS9.1K	04DS9.15K	04DS9.15	Carrier Interface•Templated•AMI
04DS9.1S	04DS9.15S	04DS9.15B	Carrier Interface•Templated•B8ZS
04DU9.1KN	04DU9.CN	04DU9.BN	Digital Access Interface•End User•AMI
04DU9.1SN	04DU9.SN	04DU9.DN	Digital Access Interface•End User•B8ZS

DS1 can be included in DS3 transmission rates offered by Qwest. Refer to Qwest Technical Publication, 77324, *Qwest DS3 Service*, for more information.

Table 4-3 NC and NCI Combination for Intra-LATA Access Service

NC code: YNS – Digital Access Channel Service (SS7-56 kbit/s Link)			
NCI code at the SPOI			
DS1 ANSI ESF	DS1 Non-ANSI ESF	DS1 SF	DS1 NCI Description
04DJ9.1K	04DJ9.15K	04DJ9.15	Carrier Interface•Joint Designed•AMI
04DJ9.1S	04DJ9.15S	04DJ9.15B	Carrier Interface•Joint Designed•B8ZS
04DS9.1K	04DS9.15K	04DS9.15	Carrier Interface•Templated•AMI
04DS9.1S	04DS9.15S	04DS9.15B	Carrier Interface•Templated•B8ZS
04DU9.1KN	04DU9.CN	04DU9.BN	Digital Access Interface•End User•AMI
04DU9.1SN	04DU9.SN	04DU9.DN	Digital Access Interface•End User•B8ZS

DS1 can be included in DS3 transmission rates offered by Qwest. Refer to Qwest Technical Publication, 77324, "*Qwest DS3 Service*", for more information.

Additional information unique to the following interfaces and channel options may be obtained from the following documents:

NCI code 04DJ9, 04DU9	Qwest Technical Publication 77375
Qwest Digital Switching Services	Qwest Technical Publication 77319

Also, Telcordia Technical Reference GR-499, "Transport Systems Generic

Requirements (TSGR): Common Requirements," defines generic requirements for digital transport systems. This includes signal interfaces, formats and coding for the interconnection of equipment at the DS1 rate. Telcordia Technical Reference GR-510, "LSSGR: System Interfaces Section 10.2," describes the DS1 signal format and code structure.

4.2 CCS Network Interface (NI) Link Configurations

The transmission interface interconnecting the Qwest CCS Local Network to an ICN CCS network is at the DS1 rate. Care must be taken in the selection of facilities and/or leased circuits so that link physical diversity is maintained as described in Subsection 2.4.2.

Figure 4-1 Qwest STP Equipped with a V.35 Port

Figure 4.1 depicts a typical 56 kbit/s signaling link configuration for a Qwest Signaling Transfer Point equipped with a DS0-A interface port.

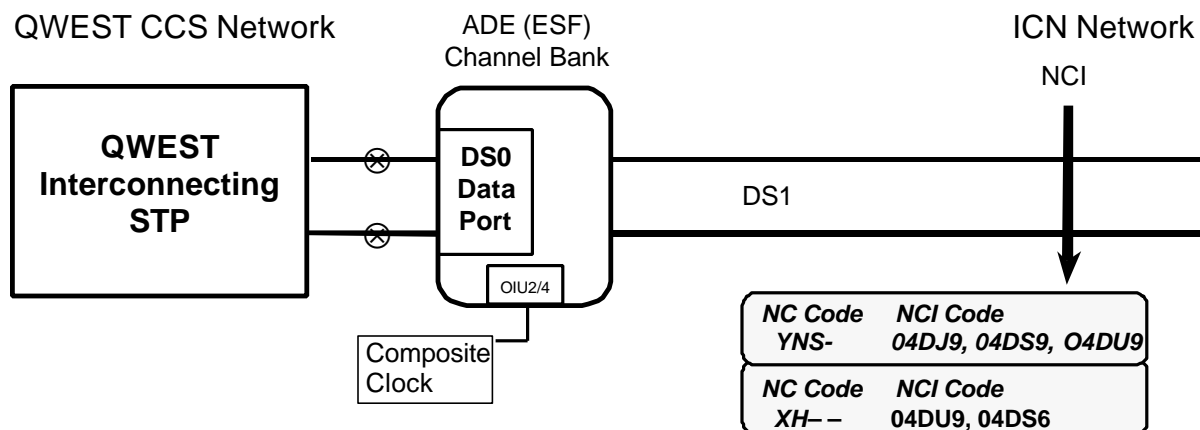

Figure 4-1 Qwest STP Equipped with a DS0-A Port

4.3 Network Channel (NC) and Network Channel Interface (NCI) Code Sets

Customer NI options and transmission parameters supported for FG D and CST 3 Services are described by channel and interface codes. This section addresses the specific NC and NCI codes used to describe and order Qwest Access Service offering CCS SS7 out-of-band signaling.

4.3.1 Network Channel (NC) Codes

The NC code is a four character code that describes the channel parameters and available channel options. Consult ANSI T1.223, *Information Interchange - Structure and Representation of Network Channel (NC) and Network Channel Interface (NCI) Codes for the North American Telecommunications System* (see Reference Section), Telcordia Generic Requirement GR-342 (see Reference Section) or Qwest Technical Publication 77319, (see Reference Section) for additional information and an expanded explanation.

Transmission parameters and Limits are documented for the different Transmission Types for FG D in Telcordia Generic Requirement GR-334, "Switched Access Service: Transmission Parameter Limits and Interface Combinations." Qwest recognizes these same types for CST 3.

Error performance parameters for the transport circuit (DS1) for FG D or CST 3 service equipped with 64 kbit/s CCC are delineated in Telcordia Technical Reference TA-NWT-000938, "Integrated Services Digital Network (ISDN): Network Transmission Interface and Performance Specifications."

The NC Codes that describe FG D or CST 3 Services with CCS SS7 out-of-band signaling offered by Qwest are shown in Table 4-4 below.

Table 4-4 NC Codes

1ST and 2ND		Character Position			
		3RD		4TH	
SDSA		S	SS7	A	FG D or CST 3
SD	Transmission Type B1 (previously Grade B)				
SDSC		S	SS7	C	FG D or CST 3 with 64 kbit/s Clear Channel Capability
SD	Transmission Type B1 (previously Grade B)				
SHSA		S	SS7	A	FG D or CST 3
SH	Transmission Type A1 (previously Grade A)				

4.3.2 Network Channel Interface (NCI) Codes

The interfaces applicable to SS7-controlled circuit-switched exchange-access trunk interfaces are grouped together with other similar interfaces and are offered in the Qwest FCC 1 Access Tariff and typically referenced in other documents as "Interface Groups." Technical descriptions of these groups are available in Telcordia Generic Requirement GR-334, (see Reference Section).

Interface Groups 1 through 10 offered by Qwest for FG D and CST 3 access services provide the option of CCS SS7 out-of-band signaling, with certain restrictions. These restrictions are not technical in nature, but relate to the availability of historical Interface Groups, which Qwest no longer offers as new service, but supports on existing service.

The NCI Codes, Interface Groups, and brief explanations of interfaces are shown in Table 4-5. Restrictions on availability of historical interfaces are noted where applicable. Detailed descriptions of the interfaces can be found in Telcordia

Generic Requirement GR-334 (see Reference Section) and Qwest Technical Publication 77324, " Qwest DS3 Service."

Table 4-5 NCI Codes and related Interface Groups FG D and CST with SS7

INTERFACE GROUP	NCI CODE AND DESCRIPTION	AVAILABILITY Standard (S) Historical (H) (NOTE 1) Not Offered (N) (NOTE 2)
1	02NO2 2-Wire No Inband Signaling	S
2	04NO2 4-Wire No Inband Signaling	S
3	04AH5.B Analog High Capacity 60 KHz to 108 KHz 12 Channels (Group)	H
4	04AH6.C Analog High Capacity 312 KHz to 552 KHz 60 Channels (Supergroup)	H
5	04AH6.D Analog High Capacity 564 KHz to 3084 KHz 600 Channels (Mastergroup)	H
6	04DS9.15 Digital 1.544 Mbit/s (DS1) 04DS9.15B Digital 1.544 Mbit/s (DS1) Superframe (SF) Format and B8ZS 04DS9.15S Digital 1.544 Mbit/s (DS1) Non-ANSI Extended Superframe (ESF) and B8ZS	S S S
7	04DS9.31 Digital 3.152 Mbit/s (DS1C)	H
8	04DS0.63 Digital 6.312 Mbit/s (DS2)	H

INTERFACE GROUP	NCI CODE AND DESCRIPTION	AVAILABILITY Standard (S) Historical (H) (NOTE 1) Not Offered (N) (NOTE 2)
9	04DS6.44 Digital 44.736 Mbit/s (DS3) 02FCF Optical Interface Capacity 2 to 36 DS3s	S N
10	04DS6.27 Digital 274.176 Mbit/s (DS4)	H
NA	02RFZ.____ Mid-Air Meet Interface 6 or 11 GHz Digital Radio Systems Capacity 3, 6, 9, or 12 DS3s	NOTE 3

Notes:

1. This Interface Group is not offered on new requests for service. Only existing FG D or CST 3 services with this Interface Group may order SS7 out-of-band signaling.
2. Customers wishing a Fiber Optic Interface may order US WEST Communications, Inc. Digital Access as Special Services (Section 7) of Qwest FCC 1 Access Tariff. These facilities may be used to provision Switched Access trunks under tariffed Shared Use Arrangements.
3. At the time of this publication, Qwest does not offer a Mid-Air Meet (Digital Radio) Interface for FG D or CST 3 Service. There is not a Switched Services Interface Group Number for this interface. It is offered as Special Services (Section 7) of Qwest FCC 1 Access Tariff.

CONTENTS

Chapter and Section	Page
5. Definitions	5-1
5.1 Acronyms.....	5-1
5.2 Glossary.....	5-2

5. Definitions

5.1 Acronyms

ABS	Alternate Billing Service
ANSI	American National Standards Institute
BSA	Basic Serving Arrangement
BDFB	Battery Distribution Fuse Board
CCC	Clear Channel Capabilities
CCS	Common Channel Signaling
CCSAC	Common Channel Signaling Access Capability
CLEC	Competitive Local Exchange Carrier
CO	Central Office
CPN	Calling Party Number
CSP	Carrier Selection Parameter
CST 3	Circuit Switched Trunk 3
ESF	Extended Superframe
EU	End-Users
EUC	End-Use Customer
FCC	Federal Communications Commission
FG D	Feature Group D
FSPOI	Facility Signaling Point of Interconnection
GTT	Global Title Translations
IAM	Initial Address Message
IC	Interexchange Carrier
ICN	InterConnecting Network
ISDN	Integrated Services Digital Network
ISDNUP	Integrated Services Digital Network User Part
ISI	Industry Support Interface
LATA	Local Access and Transport Area
LIDB	Line Information Data Base
MTP	Message Transfer Part
NC	Network Channel

NCI	Network Channel Interface
NI	Network Interface
NOF	Network Operations Forum
NPA	Number Plan Area
OSSGR	Operator Services Systems Generic Requirements
PBX	Private Branch Exchange
PRS	Primary Reference Resource
SCCP	Signaling Connection Control Part
SCP	Service Control Point
SF	Superframe
SLC	Signaling Link Codes
SMS	Service Management Systems
SP	Signaling Point
SPOI	Signaling Point of Interface
SSN	SubSystem Number
SSP	Service Switching Points
STP	Signaling Transfer Point
TCAP	Transaction Capabilities Application Part
TCIC	Trunk Circuit Identification Code
TFP	Transfer Prohibited
TT	Translation Type

5.2 Glossary

Alternate Billing Service (ABS)

ABS is the validation of calling card, collect, and third number billing services.

American National Standards Institute (ANSI)

American National Standards Institute (ANSI), as one of its stated purposes, serves as the national coordinating institution for voluntary standards, certification and related activities in the United States of America through which organizations concerned with such activities may cooperate in establishing, improving and recognizing standards, based on consensus of parties-at-interest, and certification programs to the American National Standards Institute (ANSI).

Building Integrated Timing Supply (BITS)

A binary word used for timing contained within messages.

Common Channel Signaling (CCS)

A signaling method in which a single channel conveys, by means of labeled messages, signaling information relating to a multiplicity of circuits or calls and other information, such as that used for network management. CCS is defined as a dedicated network for transporting signaling messages. The primary components of the network are STPs, signaling end points (including service control points and service switching points) and data links. The two basic types of CCS signaling are: 1) circuit-associated signaling to support trunk signaling for call control; 2) and non-circuit associated signaling to handle the exchange of queries and responses between CCS Switching Offices and data bases (SCP's) or between two CCS Switching Offices. This is also known as TCAP message routing.

Central Office (CO)

A general term usually referring to a telephone company building in which telephone equipment is installed. Also used to refer to an end office switching system.

Extended Superframe (ESF)

An Extended Superframe consists of twenty-four consecutive DS1 frames. Bit one of each frame (the F-bit) is time shared during the 24 frames to describe a 6 bit frame pattern, a 6 bit CRC remainder, and a 12 bit data link. The transfer rate of each is 2 kbit/s, and 4 kbit/s respectively.

Global Title

An address such as customer dialed digits which does not explicitly contain information that would allow routing in the signaling network, i.e., the SCCP translation function (Global Title Translation), is required.

Interexchange Carriers (IC)

Any individual partnership, association, joint-stock company, trust governmental entity or corporation engaged for hire in interstate or foreign communication by wire or radio between two LATAs.

InterConnecting Networks (ICN)

Two independent networks which connect to each other.

Line Information Data Base (LIDB)

The LIDB contains originating line, billing number and terminating line call treatment status. The LIDB is used for Alternate Billing Service calls and, in Qwest, the LIDB provides the listed directory name used in Calling Name Delivery (CNAM).

Network Channel (NC) Code

The Network Channel (NC) code is an encoded representation used to identify both switched and non-switched channel services. Included in this code set are customer options associate with individual channel services, or feature groups and other switched service.

Network Channel Interface (NCI)

The Network Channel Interface (NCI) code is an encoded representation used to identify five (5) interface elements located at a Point of Termination (POT) at a central office or at the Network Interface at a customer location. The Interface code elements are: Total Conductors, Protocol, Impedances, Protocol Options, and Transmission Level Points (TLP). (AT a digital interface the TLP element of the NCI code is not used).

Network Interface (NI)

The point of demarcation on the end-user's premises at which the Telephone Companies responsibility for the provision of Access Service ends.

Network Operations Forum (NOF)

A national committee of users, suppliers, and regulators, with the purpose of developing procedures and processes to enhance the communications arena.

Operator Services Systems Generic Requirements (OSSGR)

Is a comprehensive compilation of requirements and objectives, that, in the view of Telcordia, meet typical Operating Company operator services call handling needs. The requirements may be used by suppliers as a resource for their development of operator services systems. The OSSGR may also be used as a basis for analyzing operator systems developed by suppliers.

Service Control Point (SCP)

Serves as signaling nodes for access to data base information. Signaling messages usually consist of a query from any switch (End Office, Access Tandem, or Operator Services System, all of which can be SSP's) to a database. The message is routed first to the STP, which then forwards it to the SCP for access to the data base. The reply is passed from the SCP back to the STP, which routes it back to the originating switching office.

Service Switching Point (SSP)

Can be End Offices, Tandems, or Operator Services Switches that have CCS and SS7 capability. SSP's serve as "control points" for data base query services by suspending call processing while accessing SCP data bases to obtain information required to complete the call. 800 and Calling Card calls must be routed to an SSP office for access to the appropriate data base.

Signaling Link Codes (SLC)

A field of information in certain signaling network management messages, which indicates the identity of the affected signaling link to which the message refers.

Signaling Point (SP)

A node in a signaling network which either originates and receives signaling messages, or transfers signaling messages from one signaling link to another, or both.

Signaling Point of Interface (SPOI)

An interface in a signaling network which either originates and receives signaling messages, or transfers signaling messages from one signaling link to another, or both.

Signaling Transfer Point (STP)

A signaling point with the function of transferring signaling messages from one signaling link to another and considered exclusively from the viewpoint of the transfer. STPs are stored program control packet switches that are inter-connected with other nodes in the signaling network by digital datalinks. The STPs perform a switching function to route signaling traffic within the signaling network.

Subsystem Number (SSN)

A number to identify a user of the Signaling Connection Control Part (SCCP). The SSN is used in SCCP addressing to route an SS7 message to the appropriate subsystem at the destination node, such as 800 service at an SCP or CLASSSM services application at an end office SP.

CONTENTS

Chapter and Sections

6.	References.....	6-1
6.1	American National Standards Institute Documents.....	6-1
6.2	Telcordia Documents.....	6-1
6.3	Qwest Technical Publications.....	6-3
6.4	Other Publications.....	6-3
6.5	Ordering Information.....	6-3
6.6	Trademarks.....	6-4

6. References

6.1 American National Standards Institute (ANSI) Documents

T1.101-1999	<i>Synchronization Interface Standards</i>
T1.107-1995	<i>Digital Hierarchy - Formats Specifications</i>
T1.223-1997	<i>Information Interchange — Structure and Representation of Network Channel (NC) and Network Channel Interface (NCI) Codes for the North American Telecommunications System</i>
T1.403-1999	<i>Carrier-to-Customer Installations – DS1 Metallic Interface</i>
T1.TRQ.PP.2-2001	<i>Number Portability Switching Systems</i>
T1.TRQ No. 3	<i>Number Portability Database and Global Title Translations</i>
EIA/TIA-464-B-96	<i>Requirements for Private Branch Exchange (PBX) Switching Equipment</i>
EIA/TIA-594-1991	<i>Private Digital Network Synchronization</i>

6.2 Telcordia Documents

BR780-150-140	<i>Network Management for Toll Free Service</i>
FR-271	<i>Operator Services Systems Generic Requirements (OSSGR)</i>
GR-30	<i>LSSGR: Voiceband Data Transmission Interface, Section 6.6</i>
GR-246	<i>Telcordia Specification of Signaling System Number 7</i>
GR-310	<i>SEAS(TM) Interface Specification: User Program Layer (UPL) Application Message Descriptions and Functional Requirements</i>
GR-317	<i>LSSGR: Switching System Requirements for Call Control Using the Integrated Services Digital Network User Part (ISDNUP)</i>
GR-334	<i>Voice Grade Switched Access Service: Transmission Parameter Limits and Interface Combinations</i>

GR-342	<i>High-Capacity Digital Special Access Service Transmission Parameter Limits and Interface Combinations</i>
GR-394	<i>LSSGR: Switching System Generic Requirements for Interexchange Carrier Interconnection (ICU) Using the Integrated Services Digital Network User Part (ISDNUP)</i>
GR-436	<i>Digital Synchronization Network Plan</i>
GR-446	<i>Generic Requirements For The Administrative (AS)/Line Information Database (LIDB) - LIDB Interface</i>
GR-499	<i>Transport Systems Generic Requirements (TSGR): Common Requirements)</i>
GR-510	<i>LSSGR: System Interfaces Section 10</i>
GR-905	<i>Common Channel Signaling (CCS) Network Interface Specification (CCSNIS) Supporting Message Transfer Part (MTP), and Integrated Services Digital Network User Part (ISDNUP). A module of CCNIS, FR-905.</i>
GR-954	<i>Common Channel Signaling (CCS) Network Interface Specification Supporting Line Information Database (LIDB) Service. A module of CCNIS, FR-905.</i>
GR-1149	<i>(OSSGR) Section 10: System</i>
GR-1158	<i>OSSGR Section 22.3: Line Information DataBase</i>
GR-1188	<i>LSSGR: CLASS Feature: Calling Name Delivery Generic Requirements (FSD 01-02-1070)</i>
GR-1298	<i>AINGR: Switching Systems</i>
GR-1299	<i>AINGR: Switch - Service Control Point (SCP)/Adjunct Interface</i>
GR-1519	<i>CCSNIS Supporting TR-1188 Calling Name Delivery</i>
TR-NWT-000938	<i>Network Transmission Interface and Performance Specification Supporting Integrated Services Digital Network (ISDN)</i>

TR-NWT-000029 *Service Control Point Node Generic Requirements for IN1*

6.3 Qwest Technical Publications

77319 *Qwest Digital Switched Service*

77324 *Qwest DS3 Service*

77375 *1.544 Mbit/s Channel Interfaces*

6.4 Other Publications

Network Operations Forum (NOF) Installation and Maintenance Responsibilities SS7 Link and Trunk Installation and Maintenance Access Services

SS7 Link and Trunk Installations and Maintenance Access Services - Attachment HSS7 Cause Code and Tones & Announcements, HIIF Reference Document

6.5 Ordering Information

All documents are subject to change and their citation in this document reflects the most current information available at the time of printing. Readers are advised to check status and availability of all documents.

Employees of Qwest Corporation may order publications by submitting form RG 31-0033 to:

Central Distribution Center (CDC)
1005 17th St., S-30
Denver, CO 80202
Phone: (303) 896-9446
Fax: (303) 965-8652

Those who are not Qwest employees may order;

American National Standards Institute (ANSI) documents from:

American National Standards Institute
Attn: Customer Service
11 West 42nd Street
New York, NY 10036
Phone: (212) 642-4900
Fax: (212) 302-1286

ANSI has a catalog available which describes their publications.

Telcordia documents from:

Telcordia - Customer Services
8 Corporate Place, PYA 3A-184
Piscataway, NJ 08854-4146
Fax: (908) 699-0936
Phone: (800) 521-CORE (2673) (U. S. and Canada)
Phone: (908) 699-5800 (Others)
Web: <http://telecom-info.telcordia.com/site-cgi/ido/index.html>

Qwest Technical Publications from:

<http://www.qwest.com/techpub>

6.6 Trademarks

CLASS	Service Mark of Telcordia Inc.
DIGICOM®	Registered Trademark of Qwest Corporation
Qwest®	Registered Trademark of Qwest Corporation