

U S WEST
Communications, Inc.
Technical Publication

Central Office
Telecommunications Equipment
Standard Drawing Requirements

77352
Issue A
April, 1985

U S WEST
Communications, Inc.
Technical Publication

Central Office
Telecommunications
Equipment Standard Drawing
Requirements

Copyright Date 1985
Printed in U.S.A.
All Rights Reserved

77352
Issue A
April 1985

NOTICE

This publication is prepared as a guideline for those suppliers providing equipment drawings to U S WEST Communications, Inc.

U S WEST assume no responsibility for any costs incurred by a given manufacturer in conforming to the requirements of these guidelines. Further, conformance to these guidelines does not constitute a guarantee of acceptance of a given supplier's equipment and/or its associated documentation for the U S WEST system.

U S WEST Communications, Inc. reserves the right to revise this document for any reason, including but not limited to, conformity with standards promulgated by various governmental or regulatory agencies; utilization of advances in the state of the technical arts; or to reflect changes in the design of equipment, techniques, or procedures described or referred to herein.

Liability to anyone arising out of use or reliance upon any information set forth herein is expressly disclaimed, and no representation or warranties, expressed or implied, are made with respect to the accuracy or utility of any information set forth herein.

This document is not to be construed as a suggestion to any manufacturer to modify or change any of its products, nor does this publication represent any commitment by U S WEST Communications, Inc. to purchase any specific products. Further, conformance to this publication does not constitute a guarantee of a given supplier's equipment and/or its associated documentation.

Future issues of Technical Publication 77352 will be announced to the industry at least 45 days prior to the issuance date. This notice, which will come through our standard customer notification channels, will allow the customer time to comment on the proposed revisions.

Ordering information for U S WEST Technical Publications can be obtained from the Reference Section of this document.

If further information is required, please contact:

U S WEST Business Resources, Inc.
Manager - Information Release
1801 California, Rm. 1320
Denver, CO 80202
(303) 298-8740

Throughout this publication, the term U S WEST signifies U S WEST Communications, Inc.

COMMENTS

PLEASE TEAR OUT AND SEND YOUR COMMENTS/SUGGESTIONS TO:
U S WEST BUSINESS RESOURCES, INC.

Manager - Writing Services
1801 California, Room 1320
Denver, Colorado 80202
(303) 298-8740

Information from you helps us to improve our Publications. Please take a few moments to answer the following questions and return to the above address.

Was this Publication valuable to you in determining our requirements?

YES _____ NO _____

Was the information accurate and up-to-date?

YES _____ NO _____

Was the information easily understood?

YES _____ NO _____

Were the contents logically sequenced?

YES _____ NO _____

Were the printed pages legible?

YES _____ NO _____

Do you feel the description in the Catalog of Technical Information and/or Digest of Technical Information adequately described this Publication?

YES _____ NO _____

If you answered NO to any of the questions and/or if you have any other comments or suggestions, please explain:

(Attach additional sheet, if necessary)

Name _____ Date _____

Company _____

Address _____

Telephone Number _____

1. General

This publication outlines requirements for equipment specification, circuit schematic and wiring diagram drawings and has been prepared to provide telecommunication manufacturers with documentation guidelines. The guidelines are necessary to enable Telco personnel and their engineering and installation suppliers to engineer, install, test, and maintain telecommunication equipment.

The drawing guidelines are standards for Mountain, Northwestern, and Pacific Northwest Bell (henceforth Telcos). The Telcos may at their discretion specify additional requirements for specific installations or types of orders.

Normally satisfactory engineering and installation of manufacturer's equipment may be accomplished without the need for any proprietary information from a supplier. A submission of proprietary information is neither solicited nor expected.

1.1 Purpose

The intent of the guidelines delineated in this document are applicable and generic in nature to all types of telecommunications equipment i.e., switching and transmission. Two criteria are highlighted, namely the ordering and the external connection of the equipment(s). These criteria are illustrated through the use of drawings and description of activities so that a unified approach may be made toward the creation of standardized documents and procedures.

1.2 Content

The information included in this document includes:

1.2.1 Equipment Specification Drawings

Equipment Specification Drawings are those drawings usually provided by the manufacturer to provide for the assembly and wiring of apparatus and framework parts into units of equipment which perform specific functions. These specifications are usually in "drawing" form and contain a list of the material required, as well as assembly and wiring requirements.

The primary purpose of Equipment Specification Drawings is to allow the Engineer to identify the physical makeup of equipment and to specify items of material to be ordered and installed in a Central Office.

Typically, Equipment Specification Drawings are identified by five digit numbers which are preceded by an alpha prefix such as J, H or ED, and which are suffixed to show the serial number (A, AI, etc.) of the drawing. As changes are made or features are added to equipment by the manufacturer, the serial or issue number of Equipment Specification Drawings may change. It is important that the Engineer insure that the correct issue of a drawing be used to engineer the equipment being added on a job and also be reflected on Central Office Base Drawings.

1.2.2 Circuit Schematic Drawings

Circuit Schematic Drawings consist primarily of graphical symbols or conventions representing the apparatus components such as relays, inductors and resistors interconnected by circuit patterns.

Typically, Circuit Schematic Drawings contain the basic circuit information for a part of a communications system, and provide circuit information needed for engineering, installation, testing and maintenance of the circuit it depicts.

Circuit Schematic Drawings are typically five characters in length and are preceded by the letters "SD." An attached suffix usually indicates the serial number used to distinguish a drawing required to complete the schematic "series" for a single circuit. If more than one sheet is required, a sheet number may follow the serial number.

In some cases the manufacturer will provide a Circuit Description along with the Schematic Drawing. The Circuit Description outlines, in written form, the functions of the circuit and gives a detailed description of its operation. Usually these Circuit Descriptions carry the same number as the Schematic Drawings but are prefixed by the letters "CD."

1.2.3 Wiring Diagrams

Wiring Diagrams are those drawings created by a manufacturer, usually from Schematic Drawings, to show the actual method and type of wiring installation with respect to the physical arrangement of equipment. They may be either tabular (non-pictorial) or non-tabular (pictorial).

Wiring Diagrams are typically used in connection with the engineering, manufacturing, installation and maintenance of equipment, and show the actual method and type of wiring installation; methods of running and terminating wire; type and color of wire used; etc.

The Wiring Diagrams also may cross-reference an Equipment Specification Drawing or show other information to assist the Engineer in specifying equipment or options to be added on a job.

The Wiring Diagrams may be designated by an alpha prefix, i.e., "T," and will usually be numbered the same as the Schematic Drawings with which they are associated. As there may be more than one Wiring Diagram associated with a Schematic Drawing, the suffixes on Wiring Diagrams will vary.

1.4 Responsibility

It is intended that the documents prepared in accordance with this publication be compatible with the engineering standards established in the Central Office Telecommunications Equipment Engineering Standards for Mountain Bell, Northwestern Bell and Pacific Northwest Bell (PUB 77351) and the Central Office Telecommunications Equipment Installation and Removal Guidelines (PUB 77350). The media required by the three Operating Telephone Companies of U S WEST is discussed in the Technical Drawing Media Standards (PUB 77002).

Comments, questions or suggestions for the improvement of this publication should be submitted to:

Director, Network Engineer
Bell Tri-Co Services
Room 2802 Bell Plaza
1600 Seventh Avenue
Seattle, Washington 98191
(206) 345-3885

1. General

The following categories can serve as a check list to the equipment manufacturer to insure that the basic information has been provided.

- Master Index and Supporting Information
- Schematic Drawing
- Equipment Ordering
- Application and Connection Narrative for Identification
- Wiring Diagram

1.2 Master Index and Supporting Information

The equipment supplier should index documentation in an orderly manner. This master index should serve as the transmittal vehicle for the manufacturer's product documentation.

The approach shown in Figure 2-1 separates each functional area by utilizing alphabetical headings. Internal to each grouping the document should be sensitive to issue numbers.

MASTER INDEX																					
CONTENTS	SHEET NO.																			SHEET NO.	
		1	2	3	4	5	6	7	8	9	10	11	12	13	14	15	16	17	18		19
Master Index and Supporting Information	A1	1	2	3	4	5															A1
Detached Schematic	B1	1	2	3	3	4															B1
Stocklist	C1	1	2	3	4	4															C1
Application and Connection	D1	1	1	3	3	3															D1
Wiring Diagrams	E1	1	1	3	3	3															E1

Figure 2-1 Master Index

Supporting information may consist of notes, additional equipment required, special tools, and any special operating conditions. Suggested format is indicated by Figure 2-2.

CATEGORY	NO.
For patch cords, connectors, insertion tools, and other supporting information, refer to drawing XH-000-010	

Figure 2-2 Supporting Information

1.3 Circuit Schematic Drawings

The schematic drawing may include the following items:

- Schematic Drawing Indices and Supporting information
- Functional Schematics
- Apparatus Figures
- Engineering Notes
- Sequence Charts
- Tables
- Cabling Diagrams
- Block Diagrams
- Circuit Pack Schematics

1.3.1 Schematic Drawing Indices and Supporting Information

- A sheet index identifies the sheet on which desired information can be found. It also contains the issue number of all sheets (see Figure 2-3).
- Supporting information is depicted within a table that shows equipment drawings and equipment design requirements for the circuit (see Figure 2-4).

CONTENTS	SHEET NO.	SHEET INDEX																				
		1	2	3	4	5	6	7	8	9	10	11	12	13	14	15	16	17	18	19	20	21
SHEET NOTES SUPPORTING INFORMATION APPARATUS NOTES LEAD NOTES OPTION NOTES	1	1	2	3	4	5	6	7														
CIRCUIT NOTES INFORMATION NOTES TRANSMISSION TEST REQ TABLE	2	1	2	3	4	5	6	7														
FS 1 T, R & S LEADS	3	1	2	3	4	5	6	7														
FS 2 REGISTER LINE-SENDER LINE AND TRAIN LINE & CONNECTOR CRT CONTROL	4	1	2	3	4	5	6	7														
FS 3 CHANGE CONTROL FEATURES FS 4 CHANGE DELAY INTERRUPTED RELAYS, CHANGE DELAY FS 5 CHANGE DELAY INTERRUPTED PROTECTION	5	1	2	3	4	5	6	7														
APP FIGS. 1, 2, 3	6	1	2	3	4	5	6	7														
SC 1 NORMAL CALL	7	1	2	3	4	5	6	7														
SC 2 END OF TIMED DISCONNECT CALL SC 3 ABANDONED CALL	8	1	2	3	4	5	6	7														
SC 4 NON-CHARGE CALL	9	1	2	3	4	5	6	7														
CKT REG TABLES	10	1	2	3	4	5	6	7														
CAB1	11	1	2	3	4	5	6	7														

Figure 2-3 Sheet Index

CATEGORY	NO.
EQUIPMENT DRAWINGS	J23055H-() J23055H-()
EQUIPMENT DESIGN REG	J23055
TRUNK TABLES	J29261

Figure 2-4 Supporting Information - Schematic Drawing

- An apparatus index contains information for locating all apparatus in the functional schematic and apparatus figures (see Figure 2-5).
- A lead index provides the location on the functional schematic and cabling diagram of all leads that connect to other circuits (see Figure 2-6).
- An option index provides the location of all optional apparatus figures, all optional apparatus, and all optional wiring (see Figure 2-7).

APPARATUS INDEX

DESIG	LOCATION		
	FS	APPFIG	EQPT
RELAYS			
11A	SH5	18	1-10
11B	SH6	18	1-10
11C	SH7	18	1-10
AG, 1, 2, 4, 7	11F2	13	1-5
ASL	9A4	12	1-7
ARBO	12B2	10	1-6
ATO-1	12A6	10	1-6

Figure 2-5 Apparatus Index

LEAD INDEX

DESIG	FS LOC	CAD LOC
AUTOMATIC MONITOR REG & SDN TEST CKT		
BS	11E5	14E3
CN	11E5	14E3
FR	11E5	14E3
N	11B1	14E3
H	11E5	14E3
HB	11B1	14E3
	11E5	14E3

Figure 2-6 Lead Index

OPTION INDEX	
APP OR WIRING	LOCATION
8	APP FIG. 8
9	APP FIG. 9
19	APP FIG. 19, 64F7, 6582-5502, 67C3, 6701, 86A4, 86A5
20	APP FIG. 20
21	APP FIG. 21
FIG. A	APP FIG. A
FIG. B	APP FIG. B
Z	64H1, 54H2, 54H7, 67C2

Figure 2-7 Option Index

1.3.2 Functional Schematics

Functional schematics represent a function or a related group of functions and show the complete functioning path of a circuit (see Figure 2-8).

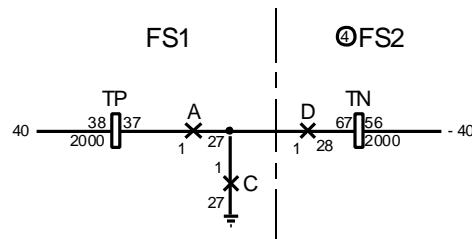

Figure 2-8 Functional Schematic

1.3.3 Apparatus Figures

Apparatus figures indicate where each piece of apparatus is shown on the functional schematic (see Figure 2-9).

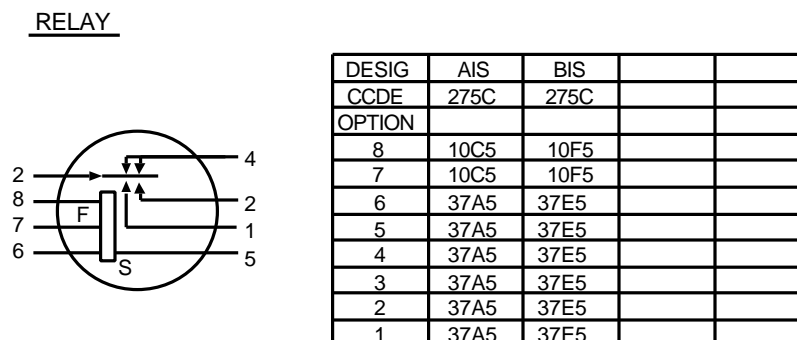

Figure 2-9 Apparatus Figure

1.3.4 Engineering Notes

Engineering notes include the following

- Circuit notes pertain to the operation of the circuit (see Figure 2-10).
- Equipment notes contain manufacturing and installation information (see Figure 2-11).
- Information notes are utilized for information of a general nature which cannot be correctly listed with other notes (see Figure 2-12).
- Cross-Connection information and notes contain information for assigning and making cross-connections that are subject to periodic changes (see Figure 2-13).
- Working limits show limiting conditions such as external circuit loops, each potential insulation resistance, etc. (see Figure 2-14).

1.3.5 Sequence Charts

- Sequence charts reflect the time order of operation and release of devices as they perform their functions in the circuit (see Figure 2-15).

FEATURE OR OPTION	PROVIDE		
	APP FIG.	APP OR WIR	QUANTITY
REGISTER CONTROL RELAYS			
DIAL PULSE COUNTING			
FOR 4 DIGITS		ZN	
FOR 5 DIGITS		ZE, ZN	
FOR 6 DIGITS		ZE, ZF, ZD	
FOR 7 DIGITS		ZE, ZF, ZC, ZP	
FOR 8 DIGITS		ZE, ZF, ZG, ZN, ZQ	
FOR 9 DIGITS		ZE, ZF, ZG, ZN, ZJ, ZR	
FOR 10 DIGITS		ZE, ZF	

Figure 2-10 Circuit Notes

EQUIPMENT NOTES:

201. ON INSTALLATIONS HAVING A SUPPLEMENTARY TRANSVERTER CONNECTOR FRAME, J22153C LEADS SWO 1, 2, 4, 7 AND VFO-4 FOR THE SIXTH AND SEVENTH TRANSVERTERS SHOULD BE CABLED TO THE STVC FRAME.
202. TRANSLATOR CIRCUITS FOR OPERATION WITH AMA MAGNETIS TAPE RECORDING SHOULD CONNECT TO AMA TRANSVERTER CONNECTOR FRAME.

Figure 2-11 Equipment Notes

INFORMATION NOTES:

301. UNLESS OTHERWISE SPECIFIED: RESISTANCE VALUES ARE IN OHMS, CAPACITANCE VALUES ARE IN MICRO FARADS, VALUES PRECEDED BY THE SYMBOL + (PLUS) OR - (MINUS) ARE IN VOLTS.

Figure 2-12 Information Notes

EQUIPMENT NOTES:

201. ON INSTALLATIONS HAVING A SUPPLEMENTARY TRANSVERTER CONNECTOR FRAME, J22153C LEADS SWO 1, 2, 4, 7 AND VFO-4 FOR THE SIXTH AND SEVENTH TRANSVERTERS SHOULD BE CABLED TO THE STVC FRAME.
202. TRANSLATOR CIRCUITS FOR OPERATION WITH AMA MAGNETIC TAPE RECORDING SHOULD CONNECT TO AMA TRANSVERTER CONNECTOR FRAME.

Figure 2-13 Cross-Connection Information and Notes

WORKING LIMITS

MAX EXT	CKT	LOOP RES	1650
MIN IHS	RES		10,000
MAX EARTH POT.			±10V

Figure 2-14 Working Limits

SYMBOLS

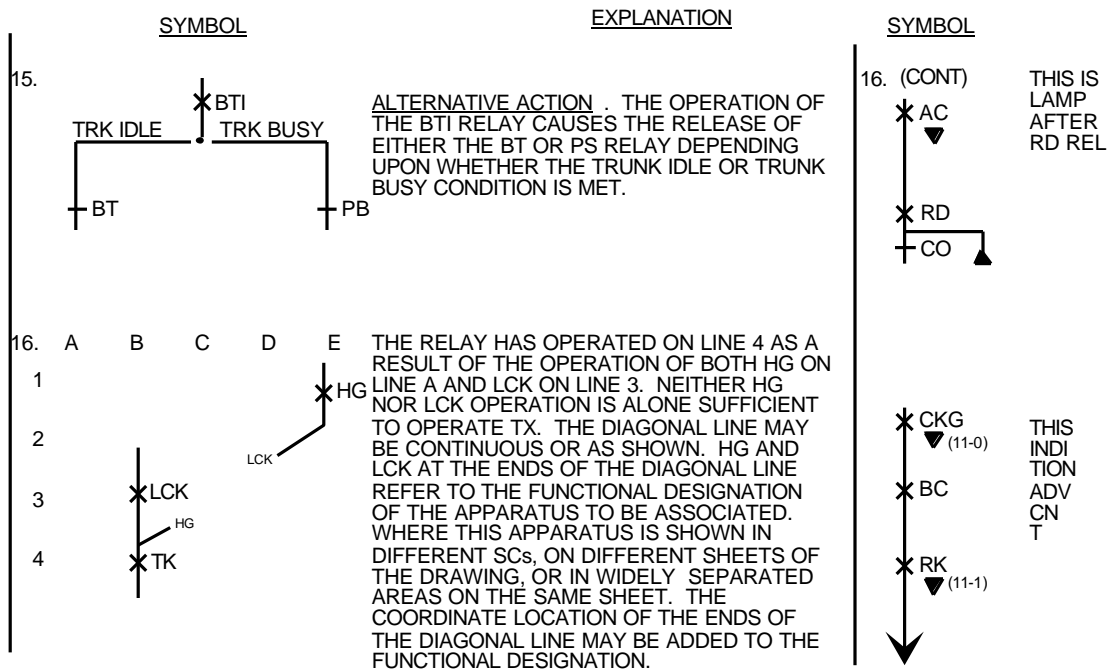

Figure 2-15 Sequence Chart

1.3.6 Tables

- Circuit requirement tables illustrate electrical and mechanical requirements to be followed when testing or adjusting equipment (see Figure 2-16).
- Timing requirement tables depict timing requirements as applied to apparatus such as relays, tubes, and relay interrupter circuits (see Figure 2-17).
- Voice-frequency drawings should include transmission test tables and notes. Frequency values used in the measurement should be shown in hertz (Hz), kilohertz (kHz), etc. (see Figure 2-18).

CIRCUIT REQUIREMENTS																COORD NODE												
ORIGINATING REGISTER CIRCUIT - DIAL PULSING (OR)																1												
APPARATUS				WORK ROBT			CLOSED PREPARATION			QUINCY CURRENT PLOW						REMARKS												
DEMO	CODE	OPTIO	PHL	SOP FIG	COT PET	AQL TUR	BLAME OR HUMILIATE	TEST CLIP BOARD		TEST MY PREP	SEE TEST NOTE	TEST WOG	TEST FOR	AFTER SAND	TEST		MAGD											
								CARD ME	CARD ME																			
RELAYS																												
11A	4F3		18				1RAIQ		U(11A)	GRC			O		31	29.5												
MID	4F57		18				1RAIQ		U(11B)	GRC			O		27	29.5												
11C	1/2 ARE		18					20(11C)	IU(11C)	B7G			O		3.2	3.7	MOUNTEC WITH (AS)											
EP	4F24		13				(PRL)0		U(TP)	GRC			O		27	25.5												
<p>TEST NOTES:</p> <p>1. CONNECT GROUND TO TERMINAL OF RELAY UNDER TEST (1,4,8,9,10 FOR -0,-1,-2,-4,-7 RESPECTIVELY). PROCEDURE FOR TESTING DRY REED RELAYS USED FOR REGISTERING DIGITS.</p> <p>PREPARATION:</p> <p>CONNECT DIRECT BATTERY TO TERMINAL L2 OF TEST SET. PLACE L KEY IN NEUTRAL POSITION CONNECT SLEEVE OF TEST T & A TO LOAD CONTACT (5,7,11,12,13 FOR -0,-1,-2,-4,-7 RESPECTIVELY) OF RELAY UNDER TEST. ADJUST RED RHEOSTAT 4 AND THE THREE 4 SWITCHES FOR MINIMUM RESISTANCE. CONNECT THE TIP OF THE 4W JACK TO TERMINAL (3) OF THE RELAY UNDER TEST.</p> <table style="width:100%; border:none;"> <tr> <td style="text-align:center"><u>STEP</u></td> <td style="text-align:center"><u>PROCEDURE</u></td> <td style="text-align:center"><u>INDICATION</u></td> <td style="text-align:center"><u>CHECK</u></td> </tr> <tr> <td style="text-align:center">A.</td> <td style="text-align:center">CLOSE OPERATE & RELEASE KEYS.</td> <td style="text-align:center">LAMP LIGHTED</td> <td style="text-align:center">CLOSURE OF LOAD</td> </tr> <tr> <td style="text-align:center">B.</td> <td style="text-align:center">CLOSE HOLD KEY & OPER OPERATE KEY.</td> <td style="text-align:center">LAMP REMAINS LIGHTED.</td> <td></td> </tr> </table>																	<u>STEP</u>	<u>PROCEDURE</u>	<u>INDICATION</u>	<u>CHECK</u>	A.	CLOSE OPERATE & RELEASE KEYS.	LAMP LIGHTED	CLOSURE OF LOAD	B.	CLOSE HOLD KEY & OPER OPERATE KEY.	LAMP REMAINS LIGHTED.	
<u>STEP</u>	<u>PROCEDURE</u>	<u>INDICATION</u>	<u>CHECK</u>																									
A.	CLOSE OPERATE & RELEASE KEYS.	LAMP LIGHTED	CLOSURE OF LOAD																									
B.	CLOSE HOLD KEY & OPER OPERATE KEY.	LAMP REMAINS LIGHTED.																										

AGE 5) PAGE 1

Figure 2-16 Circuit Requirements Table

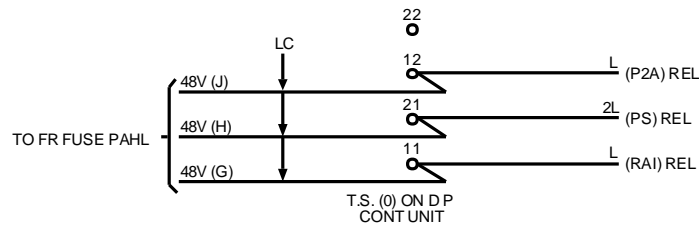

Figure 2-19 Cabling Diagram

1.3.8 Block Diagrams

Block diagrams are provided to convey significant functional relationships between circuits. Block diagrams are used for electronic components only (see Figure 2-20).

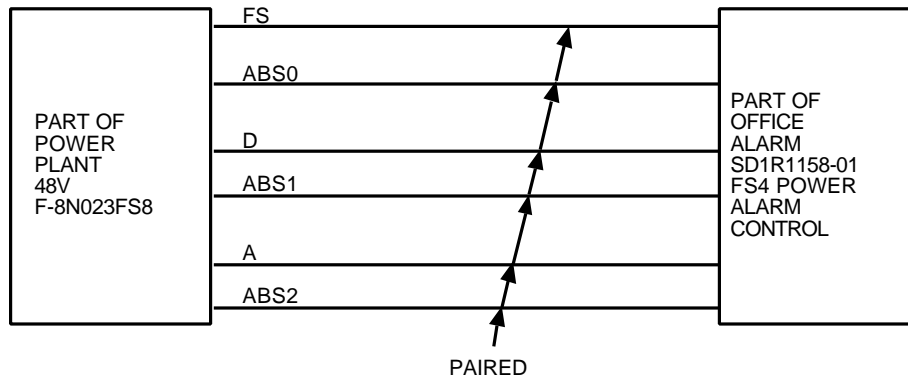

Figure 2-20 Block Diagram

1.3.9 Circuit Pack Schematics

Circuit pack schematics show the individual components within the circuit pack and how they are interconnected. Circuit pack schematics are used with electronic components only (see Figure 2-21).

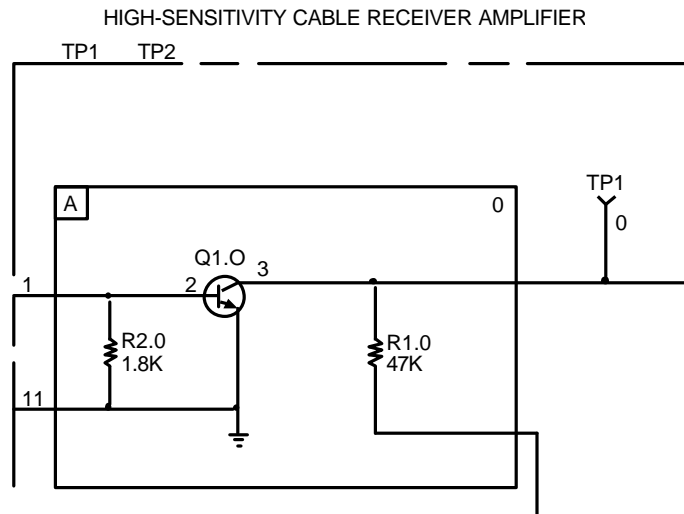

Figure 2-21 Sample Circuit Pack Schematic

1.4 Equipment Ordering

The manufacturer should provide a narrative or functional description of the equipment and its use encompassing the specific information required for ordering (see Figure 2-22).

The document must include a stocklist which provides a breakdown of all components by quantity, code, and model or vintage. Where required, installation or manufacturing notes may be cross-referenced to any individual component (see Figure 2-23).

LINE	EQUIPMENT	RATING	LIST
1	FRAMEWORK, ASSEMBLY, WIRING AND EQUIPMENT FOR ONE STATUS POLLING CENTRAL CONTROL SYSTEM		1
2	ASSEMBLY, WIRING AND EQUIPMENT REQUIRED IN ADDITION TO LIST 1 TO PROVIDE DATA FACILITY TEST JACKS		2
~~~~~			
11	WIRING AND EQUIPMENT FOR LINE UNIT E/W 4W-4W BRIDGE ACCEPTING 1 TO .16	MFR DISC.	A
12	REMOTE STATIONS ALWAYS REQUIRED IN ADDITION TO LIST 1		B
~~~~~			
51	WIRING REQUIRED IN ADDITION TO LIST 1	75 BPS	WA
52	FOR DATA TELEGRAPH CHANNELS USED WITH	105 BPS	WB

Figure 2-22 Equipment Product Drawing - Tabular Information

A	B	C	D
STOCKLIST			
LIST	QTY PER LIST	IDENT NO.	DESCRIPTION
1	1	ED-10000-70 GR 9	RELAY RACK ASSEMBLY
1	2	H-001-001 DET 26	BLANK PANEL
1	1	LCJ10001A-3 GR 1	LOCAL CABLE
1,2,3	1	J10000A-1 L1, A WA	MONITOR AMPLIFIER UNIT
1,2,3	1	840254585	COVER ASSEMBLY
2,3	1		S3B CORD, RED 6-0 LONG E/W
2,3	1		310 PLUG, GREY SHELL
2,3	1		KS-13492 L1 RESISTOR 1000
1,2,3	4	P-353447	SCREW, SPL RHM. 216 X 1/2
2,3	1	P-225678	CLIP
1	1		INDICATOR LIGHT BEPH-GL 128-WBL-X (SHELLY) OR EQUIV

Figure 2-23 Equipment Product Drawing - Stocklist

1.5 Application and Connection Narrative for Identification

In order to properly identify the equipment, the following information is required.

- Name of unit
- Description of circuit features
- Circuit capacity of unit
- Area of use
- Physical dimensions

This information may be presented as indicated by Figure 2-24.

NOTICE:- NOT FOR USE OR DISCLOSURE OUTSIDE THE BELL SYSTEM EXCEPT UNDER WRITTEN AGREEMENT			
SUPERSEDED BY ISSUE 8			
STEP-BY-STEP SYSTEM SPECIFICATION FOR 350A COIN TRUNK EQUIPMENT	1099	AT&T CO RATING AT&T CO STANDARD	
		WECO RATING STANDARD	
FOR USE PRECEDING A FIRST SELECTOR SERVING PREPAYMENT COIN LINES 23 INCH 3 MTG PLT SINGLE CKT UNIT SURFACE WIRED	DWG SIZE	ISSUE	
	6S	7	
WESTERN ELECTRIC	ED-12345-30	SHEET 1 OF 12	

(a) FIRST SHEET FORMAT

SUPERSEDED BY ISSUE 4		
SPECIFICATION FOR 350A COIN TRUNK EQUIPMENT	DWG SIZE	
	6S	ISSUE 3
WESTERN ELECTRIC	ED-12345-30	SHEET 5

(b) SUPPLEMENTARY SHEET FORMAT

Figure 2-24 Narrative for Identification

An application schematic is a pictorial block diagram which depicts the relationship of the unit and its support equipment (see Figure 2-25).

Figure 2-25 Application Schematic

The following information is required to properly interconnect, fasten, and support equipment:

- A cabling plan is a sketch showing the location and termination of cabling (see Figure 2-25).
- Material requirements specify cable type and terminating equipment.
- Reference must be made to support drawings to furnish information to properly terminate the unit.
- Superstructure requirements and fastening details must show provisions for cable rack mounting and fastening details of the unit (see Figure 2-26).

Figure 2-25 Cabling Plan

Figure 2-26 Cable Rack Mounting and Fastening Details

1.6 Wiring Diagram

Wiring diagrams consists of three parts.

- Engineering information: This part contains engineering information for various circuit features and indicates requirements for switchboard cable and external wiring in pictorial form. Refer to Figures 2-27 through 2-30.
- Internal Wired Components: This part provides a list of all internally wired components by functional designation in alphabetical and numerical order (Figure 2-31). Following the list of wired components is a listing of all pigtail components and their connections as shown by Figure 2-32.
- Detailed run information: Contains the detailed wiring run information arranged numerically from run No. 1 up as indicated in Figure 2-33.

For further information on wiring diagrams, refer to Bell Communications Research PUB 53325, Tabular Wiring Diagrams-Description.

Figure 2-27 Sheet Index - Wiring Diagram

Figure 2-28 Record of Figures, Components, and Wiring Change - Wiring Diagram

Figure 2-29 Cross-Reference Table - Wiring Diagram

Figure 2-30 Cabling Plan - Wiring Diagram

Figure 2-31 List of Internal Wired Components - Wiring Diagram

Figure 2-32 List of Pigtail Components and Their Connections - Wiring Diagram

Figure 2-33 Detailed Run Information - Wiring Diagram

1. General

Equipment Specification Drawing convey both design and functional requirements for the assembly of electronic, electrical, electro-mechanical, or mechanical components into equipment for use in communication systems. These drawings generally fall into two broad categories: those used to convey only engineering requirements and those used to convey both engineering and manufacturing requirements. Engineering and manufacturing requirement drawings differ from the engineering requirement drawings mainly with respect to the inclusion of stocklist and such supplementary information relative to ordering specific features and associated supporting information as is contained in separate tables.

Since these drawings convey both engineering and manufacturing requirements, they are basically suited for use directly in the manufacture or installation of the equipment. Typical of this information are the requirement detail drawings and lists of associated drawings such as wiring diagram drawings, etc.

For requirements applicable to the preparation of equipment detail drawings or a combination of equipment detail and partial assembly drawings associated with engineering requirement or engineering and manufacturing requirement drawings, refer to Bell Communications Research PUB 53145, Illustration Specification.

2. Drawing Identification Information Fields

For purpose of identification and ready reference, certain drawing information is grouped and shown in specific fields in the lower right corner on every drawing sheet. The information shown in a specific field is:

- Ownership
- Drawing Number
- Sheet Number
- Drawing Size
- Issue
- Title
- Rating Status
- Restrictive Notice

Common information to all drawings include the following:

- On first sheet drawing formats, the applicable identification information fields are as shown in Figure 3-A(a).
- On supplementary sheet drawing formats, the applicable identification fields are as shown in Figure 3-A(b).

- In applications where drawing sheets are formatted into page-type information, the title box may be rotated counterclockwise, see Figure 3-A(c). This will provide drawing space for the maximum number of page formats on a given sheet, providing the page format layout is also rotated 90 degrees counterclockwise from the border at the bottom of the sheet. When the drawing is multisheet, the rotated title box is shown on all sheets.

In addition to the main drawing number box shown in Figure 3-A (a), (b), and (c), a supplementary box for entering the drawing number is shown in the lower-left corner of every drawing sheet, see Figure 3-A (d).

Unless otherwise specified, all lettering for drawing identification information should be 1/8 inch high.

Figure 3-A Drawing Identification Information Fields

An ownership field appears on all drawing sheets to identify the manufacturer of the product.

A drawing number field must appear on all drawing sheets. The drawing number appears in the main and supplementary drawing number boxes lettered in 3/16 inch characters (see Figure 3-B). The numbering should be centered between the top and bottom borders of the number box, and the first character should be approximately 1/8 inch from the left border of the box, in order to conform to Telco microfilm standards. As with Circuit Schematic Drawings and Wiring Diagrams, the associated Equipment Specification Drawing number may conform to any appropriate numbering scheme assigned by the product manufacturer.

A sheet number field appears on all drawing sheets (see Figure 3-B). On single sheet drawings, no sheet indication is shown in the sheet number field.

SUPERSEDED BY ISSUE 8		
STEP-BY-STEP SPECIFICATION FOR 350A COIN TRUNK EQUIPMENT FOR USE PRECEDING A FIRST SELECTOR SERVING PREPAYMENT COIN LINES 23 INCH 3 MTG PLT SINGLE CKT UNIT SURFACE WIRED	1099	AT&T CO RATING AT&T CO STANDARD
		WECO RATING STANDARD
	DWG 6S	ISSUE 7
WESTERN ELECTRIC	ED-12345-30	SHEET 1 OF 12

(a) FIRST SHEET FORMAT

SUPERSEDED BY ISSUE 4		
SPECIFICATION FOR 350A COIN TRUNK EQUIPMENT		
	DWS SIZE 6S	ISSUE 3
WESTERN ELECTRIC	ED-12345-30	SHEET 5

(b) SUPPLEMENTARY SHEET FORMAT

Figure 3-B Drawing Identification Information --Entries

A drawing size field appears on all drawing sheets. The drawing size designation should appear in the drawing size box in 1/8 inch characters, if the manufacturer assigns size codes to the product drawing.

A drawing issue field appears on all drawing sheets in the issue number box. The current issue should be recorded in accordance with the following:

- **Single Sheet Drawing** The issue posted is in addition to and agrees with the latest issue posted in the Issue and Revision Note column.
- **Multisheet Drawing:** The issue posted on the first sheet of the drawing is in addition to and agrees with the latest issue posted in the Issue and Revision Note column shown on the first sheet. Issues posted on supplementary sheets of the drawing are as follows:
 - If the drawing is reissued on a total sheet reissue basis, the issue posted on each supplementary sheet should be identical to the latest issue posted on the first sheet.
 - If the drawing is reissued on an individual sheet basis, the issue posted on each supplementary sheet depends upon the revision activity of each sheet. On a revision, irrespective of its present issue, the issue posted on each reissued supplementary sheet should be identical to the latest issue posted on the first sheet.

A drawing title field appears on all drawing sheets. The drawing title information appears in the drawing title box as shown in Figure 3-B. The composition of the title information comprises the main and supporting title information as shown in Figure 3-C. The main information indicates the particular system for which the drawing is used and the type of design covered by the drawing. The supporting information indicates the general system for which the drawing is used and the particular application, special features, and equipment designation, if applicable, of the design covered by the drawing.

Figure 3-C Composition of Title Information

In title information, abbreviations shown are those shown in Bell Communications Research PUB 53351, Wiring Symbols, Wiring Abbreviations, and Definitions-Wiring and Cabling.

A rating field appears only on first sheet formats. When applicable, the rating is shown in the rating box and drawing ratings should conform to the manufacturer's conventions.

An Issue and Revision Note field appears on all first sheet formats in a right border column (see Figure 3-D). The column generally extends downward to the top of the drawing identification information field. The following information is pertinent:

- The issue number is shown in the issue number box. The number 1 should be assigned to the original issue of the drawing and subsequent revisions to the drawing are sequentially added to the column with each reissue carrying the next highest number.
- The date of Issue 1 and all subsequent issues of the drawing should be no later than the date that the drawing is available for general use. Original issue date information is shown directly above the issue number box. Subsequent issue date information is shown directly above the first approval box for each revision.
- Approval signatures (initials) are shown in the approval boxes indicated in Figure 3-D (a).
- On Issue 2 and all subsequent issues of the drawing, unless otherwise specified, all drawing changes are recorded as revision notes in the field preceding the issue and approval boxes shown for each issue.

Figure 3-D Issue and Revision Note Column Format

The revision notes cover a brief but complete record of the information, that is: changed (information revised); removed (information erased); added (information added); canceled (information lined out or cross-hatched); and transferred (information transposed to another drawing. The method of recording revision notes usually depends entirely upon the format of the drawing information. As a general guide, the following is recommended.

- For revisions to tabular formats, specific features are incorporated in the format of the stocklist and tables primarily for referencing the revisions in the revision notes.
- For information erased from the drawing, record the information removed.
- For the addition of new features such as, lists, groups, figures, etc., refer to the feature added.
- For revisions to pictorial information and notes, reference the changes, removals, etc., in a manner most suitable to the form of the information revised.

On the existing drawing, in no case should the previously recorded revisions be altered or erased from the drawing.

When a drawing is superseded by another drawing having the same drawing number, none of the issues and associated revision notes on the superseded drawing should be transferred to the superseding drawing.

3. Notes

When information on the drawing can be conveyed in words of sufficient clarity in the form of notes, this method of presentation is used instead of showing graphic layouts such as views, sections, etc. Notes are also used to supplement the information shown in graphic layouts, stocklists, or tables.

Notes are shown ~ the first sheet of the drawing. information in note form may ~e classified as notes, manufacturing notes, or engineering notes. These designations and the drawing field in which they are shown depend upon the type of drawing prepared as covered in the following:

- Engineering Requirement Drawings: The information in note form on these drawings covers engineering information only, and the notes required are shown under the heading NOTES.
- Engineering and Manufacturing Requirement Drawings: The information in note form on these drawings may cover manufacturing information or

engineering information, or both. Notes required to cover manufacturing information are shown under the heading MANUFACTURING NOTES, and notes required to cover engineering information are shown under the heading ENGINEERING NOTES.

Notes-Field and Numbering: On engineering requirement drawings, all notes are grouped in one field, shown directly below the top border of the sheet and adjacent to the Issue and Revision Note column (Figure 3-E), or in any other position on the drawing as considered appropriate by the manufacturer. Notes are numbered sequentially, starting with the number 1 and are listed from the top down under the heading shown in Figure 3-E. When the drawing area beneath this heading is fully used, additional notes may be continued in a similar field to the left of, or as nearly adjacent to the initial note field as possible.

Figure 3-E Notes Field

Manufacturing Notes-Field and Numbering: On engineering and manufacturing requirement drawings, the manufacturing notes cover information affecting manufacturing or installation. The notes are grouped in one field, shown directly below the top border of the drawing and adjacent to the Issue and Revision Note column as shown in Figure 3-F.

Figure 3-F Manufacturing Notes Field

- Notes are all numbered sequentially, starting with the number 1 and are listed from the top down under the heading shown in Figure 3-F. When the drawing area beneath this heading is fully used, additional notes may be continued in a similar field to the left of, or as nearly adjacent to the initial note field as possible.

- In the event more than 50 manufacturing notes are required, the notes can be numbered in the ranges of 1 to 50, 101 to 150, 201 to 250, etc., or as considered appropriate by the manufacturer.
- Shop-or Installer-Affected Notes: In the two columns designated SHOP and INSTL, an indication that the note shown applies to Manufacturing or Installation, or both is shown by entering an "X" in the appropriate column against the particular note. Notes which convey meanings of symbols shown on the drawing are not designated with an "X" in either column.

Symbol, Convention, and Letter-Designated Notes: Notes Listed under NOTES or MANUFACTURING NOTES involving the interpretation of symbols, conventions, letter designations, or special characters are composed so that the symbol, convention, letter designation or special character appears as the first part of the note, and is followed by the descriptive interpretation. Each symbol, convention, letter designation, or special character is covered by an individual note.

Specific Notes or Manufacturing Notes: Notes applicable to certain drawing types are listed in Section II of these guidelines.

General Notes or Manufacturing Notes: The following notes occur with sufficient frequency to warrant standardization of their expression and the use of symbols or special characters. These notes may be used on drawings where they are applicable. Avoid changing the standard expression, or the associated symbol or special character. Although these notes may not be initially shown on a drawing, consider their future application, and avoid the use of their associated symbols or special characters for other purposes, such as the use-of parentheses to enclose references to other information on the drawing.

1. () - INDICATES DESIGNATIONS TO BE STAMPED IN ACCORDANCE WITH JOB INFORMATION.
2. [] - INDICATES DESIGNATIONS SHOWN FOR INFORMATION ONLY AND ARE NOT TO BE STAMPED.
3. < > - INDICATES INFORMATION PROVIDED IN ACCORDANCE WITH OTHER INFORMATION.
4. O or ~ ~ INDICATES DESIGNATIONS TO BE STAMPED ON WIRING SIDE ONLY.
5. TERMINAL STRIPS TO BE SHIPPED LESS MOUNTING SCREW, NUTS, AND WASHERS

Note 5 has application only on drawings with stocklists and is generally specified when fastening parts furnished with the terminal strip and are to be replaced by other parts to satisfy a particular mounting condition.

6. ALL PARTS NOT OTHERWISE INDICATED ARE ASSEMBLED FOR SHIPMENT WHEN ORDERED WITH LIST ().

Note 6 has application only on drawings with stocklists. The main lists are specified in place of the parenthesis and the note may be used when a specific assembly of a main list cannot be conveyed by the use of the standard assembly and shipping notes.

7. LIST () IS ASSEMBLED AND WIRED INDIVIDUALLY WHEN ORDERED SEPARATELY.

Note 7 has application only on drawings with stocklists. Secondary lists covering separate entities are specified in place of the parenthesis, and the note may be used when the separate assembly of supplementary Lists cannot be conveyed by the use of the standard assembly and shipping notes.

8. C - INDICATES APPARATUS TO BE MOUNTED IN CONSECUTIVE ORDER POSITIONS INDICATED.

Note 8 has application only on drawings with stocklists and is used when specific apparatus must be mounted in a certain sequence.

Engineering Notes-Field and Numbering: On engineering and 1 manufacturing requirement drawings, the engineering notes cover information pertaining to requirements which control the design, function, application, and appearance of the design covered by the drawing. Engineering notes are not comprised of symbols, conventions special characters, and information interpreting such designations. The notes are grouped in one field generally shown adjacent to the Issue and Revision Note column (see Figure 3-G). This field is located in an area between the manufacturing notes and title box, depending upon the drawing space required or reserved for manufacturing notes.

Figure 3-G Engineering Note Field

- Notes are numbered sequentially, starting with the number 51 and are listed from the top down under the heading shown in Figure 3-H or the boxed area. When the drawing area beneath this heading is fully used, additional notes may be continued in a similar field to the left of, or as nearly adjacent to the initial note field as possible. On framework assembly drawings, the notes generally are continued near the top border of the drawing to the left of the field reserved for manufacturing notes similar to Figure 3-G.

Figure 3-H Tabular Form of Engineering Note 51

- In the event that more than 50 engineering notes are required, the notes can be numbered in the ranges of 51 to 100, 151 to 200, 251 to 300, etc.

Source of Design-Note 51: All drawings made from other drawings or design sources should refer to these drawings or design sources in a Note 51. If more than one design source is used, all the sources should be listed. Note 51 is always used or reserved for this reference, and is not used for any other purpose. If no design reference is to be listed, Note 51 should be left unused. Any other notes required should begin with Note 52. When used, Note 51 should appear as follows.

- Equipment Assembly Containing Wiring Information - On drawings of equipment assemblies such as printed wiring assemblies or certain equipment for which the assembly drawing includes wiring information that would otherwise normally appear on a wiring diagram, Note 51 on the assembly drawing should, in addition to listing the design sources, cross-reference the issue of the assembly drawing with the issues of the design sources in tabular form as shown in Figure 3-H. Changes made to this form of Note 51 are not recorded in the revision notes.

- All Other Drawings - Unless otherwise specified, no cross-reference between the issue of the drawing and the issues of the design sources is required, and Note 51 appears in accordance with the following:
 - 51. INFORMATION FURNISHED PER THIS DRAWING IS ACCORDANCE WITH_____.
 - Changes made to this form of Note 51 are recorded in the revision notes simply as: NOTE 51 CHANGED.
 - Insert manufacturers reference number in the blank above.

Other Engineering Notes: These notes reflect information of engineering significance, which may include information pertaining to the following:

- Function
- Application
- Appearance
- Additional assemblies, units, components, parts, etc. required
- Specific ordering information for the arrangement of the design covered

4. Multisheet Drawings

The following requirements are applicable to multisheet Equipment Specification Drawings other than Wiring Diagram type drawings.

- The general format of the sheet index used on the first sheet of a multisheet drawing is as shown in Figure 3-J. This record of sheet numbers and respective issues is an index and should not be assigned a table designation. Individual sheets are listed in sequence starting with the first sheet.

Figure 3-J Sheet Index

- The issue number posted depends upon the revision activity of each sheet. After the initial issue, subsequent issues can be posted only against those sheets that are revised. Sheets not changed retain their existing issues. The issues shown should agree with the latest issue of the respective sheets. Previous recorded issues are removed only when the limits of the index shown on the drawing are exceeded. If the drawing sheet containing the index is superseded, only the latest issue of each sheet need be recorded in the index on the superseding drawing.
- When an automatic change has been incorporated on a drawing sheet, an indication of such a change is shown in the sheet index in accordance with the following:
 - All drawings which specify coded apparatus, coded cable, or coded wire are subject to automatic changes, and when the sheet index is shown on these drawings, the automatic change indication columns can either be initially included with the index, or provisions can be made to leave drawing space for the addition of the columns when required.
 - When automatic changes are recorded in the sheet index, the automatic change indication boxes at the top of the Issue and Revision Note column in Figure 3-D are not used.
 - When the sheet containing the index is superseded due to redraw or reproduction processes, all previously indicated automatic change designations on the superseded sheet are shown in the index on the superseding sheet.
- When a revision of a multisheet drawing results in the elimination of certain sheets, and the remaining sheets are not renumbered, the sheets to be canceled are lined out in the sheet index.
- Once canceled and lined out, the canceled sheet may be reinstated if the sheet is used again to show drawing information. In this case, the issue of the reinstated sheet is the same as the highest issue of the first sheet.
- The information shown in the sheet index reflects the status of the drawing sheets. When required, the status of any sheet will be treated individually in the revision notes, and therefore, any revisions pertaining to the sheet index are not recorded in the revision notes.

Information should be shown in page-type formats on drawings only where it is intended to provide for placing paper copy reproductions in books or loose leaf binders. Page-type formats shown on drawings should adhere to the following requirements.

- The overall sizes of page formats is as shown in Figure 3-K. The use of page size 11" x 17" is restricted to conditions where the informational content presented in page form cannot be shown on an 8.5" x 11" page without loss of clarity.

Figure 3-K Page Type Formats

- Each page should contain the following basic identification information:
 - Drawing Number: Is shown on each page and should be identical to the number of the drawing on which the page format is shown.
 - Issue Number The issue number posted for each page should agree with the latest issue of the drawing as a whole. If the page format contains Issue Number Assignment boxes, the issues should be posted sequentially. If Issue Number Assignment boxes are used, previous recorded issues on each page should be erased only when the limits of the Issue Number Assignment boxes are exceeded. If the drawing is superseded by a redraw or reproduction, omit all prior recorded issues on the page and start the issue number with the superseding issue of the drawing.
 - Page Number: When the drawing contains two or more page formats, page numbers should be assigned consecutively throughout the drawing starting with the number 1. Page identification is indicated by PAGE 2, PAGE 3, etc. The term SHEET is to used to designate page numbering. On the first page only, the total number of pages is indicated by PAGE 1 of, followed by only the number representing the total pages, as for example: PAGE 1 of 12.

- **Title Information:** This information is shown on the first page only.

5. Lined Out Drawing Information

Lining out portions of a drawing may be used where the information must be preserved for a permanent record. However, lining out of information often causes the information to become illegible. In addition to the preservation of existing information, the use of line outs in stocklists, or for automatic changes in the body of the drawing may have special significance to manufacturing and other users of the drawing.

In general, the use of line outs on drawings should be limited to notes and table information. However, in either application, portions of the information such as, a single word or phrases in notes or individual column entries in tables should not be lined out. In the case of notes, the entire note should be lined out. In the case of table information, the information in all the columns (except line number if shown) for the particular entry should be lined out.

Where the information is lined out for purposes of avoiding lengthy revision notes, the lined out information is treated in the revision notes as canceled information.

Unless otherwise specified, line outs should be continuous horizontal lines drawn with a thin lineweight.

When a drawing containing lined out information is superseded due to redraw or reproduction processes, the following applies to showing the existing lined out information on the superseding drawing.

- Ascertain which portion of the information was lined out for purposes of avoiding lengthy revision notes, and which portion was lined out to maintain a permanent record of the information.
- Information Lined out for purposes of avoiding lengthy revision notes is not shown on the superseding drawing. All other line outs are considered permanent record type changes, and this lined out form of information should be retained on the superseding drawing.

6. Cross-Hatched Drawing Information

Cross hatching portions of the information on a drawing is used to indicate that the affected information is no longer applicable as part of the design covered by the drawing. Cross hatching can be used where the information involved is not required for a permanent record and could otherwise be completely erased from the drawing.

Cross hatched information is treated in revision notes as canceled information.

The usual procedure for cross hatching is to draw a grid pattern with uniformly spaced lines 45 and 135 degrees from the horizontal using thin lineweights. The

spacing between lines depends upon the information area involved. The general rule is to draw the minimum number of lines required to ensure that the cross hatching is evident.

7. Assembly Layouts

Assembly layouts are prepared to present information incorporating the arrangement and identification of the component parts which enter into the assembly of the design as follows:

- **Engineering Requirement Drawings:** The designs covered on these drawings do not include any ordering information, and the content of the drawing is comprised principally of assembly layouts and supporting information in the form of notes that may be required.
- **Engineering and Manufacturing Requirement Drawings:** The designs covered on these drawings include ordering information, and the drawings may be of the following types.
 - **Equipment Assembly Drawing** In addition to the assembly layouts, this drawing includes the stocklist, supplementary information tables, and manufacturing and engineering notes.
 - **Framework Assembly Drawing:** In addition to the assembly layouts, this drawing includes the stocklist and manufacturing and engineering notes.
 - **Stocklist and Tables:** Requirements for stocklists and supplementary information tables are to be found with the assembly layouts.

Assembly layouts usually include one or more views consisting of the main, supplementary, and rear views as follows:

- The main view is the principal layout and generally includes the major component parts that enter into the assembly. Depending upon the complexity of the design covered or if the design covers a number of major assemblies, a drawing may contain one or more main views. Each main view may consist of a front view, plan view, end view, and rear or bottom view. In general, the views shown are as follows.
 - On frame layouts of equipment units, the front view is always required, and the plan or end views are optional.
 - On mounting plate equipment unit layouts, usually only the front view is required.
 - On chassis and similar type equipment unit layouts, front, plan, end, and rear or bottom views are usually required.

- On framework layouts, the front, plan, and end views are usually required.
- Supplementary Views: The main view may be supplemented by other more detailed layouts classified as figures, views, sections, and sketches.
- Rear Views: This view is usually required only when the assembly consists of an almost equal number of component parts on the front and rear of the assembly, or where the front view alone cannot clearly convey the arrangement of the component parts located on the rear of the assembly. In certain cases, partial rear views may be sufficient to convey the required rear assembly information.

Letter designations for sections and views are assigned in alphabetical sequence. The same letter designation is not duplicated in either a section or view. An example of the appropriate sequence and assignment would be: VIEW A-A, SECT. B-B, VIEW C-C, VIEW D-D, SECT. E-E. On a multisheet drawing, it is preferred that the designation of main and supplementary views be assigned in a left-to-right page reading sequence throughout the drawing.

Designating each mounting plate with a sketch designation applies only to mounting plates in assemblies with a stocklist. The sketch designation is shown on the right adjacent to the mounting plate view, and does not replace the lettered figure designation of the mounting plate layout.

For general guidance on usable scales for assembly drawings, the following list indicates recommended scale applications for the representation of figures, views, sections, etc. The scales may be varied as required for purposes of improving clarity or when available usable drawing area is limited. Attention should be given to providing space for entering information in accordance with lettering standards.

<u>APPLICATION</u>	<u>SCALE</u>
Figures	1/1 or 1/2
Views and Sections	1/1 or 1/2
Submit assemblies	1/1 or 1/2
Equipment units	1/2

In general, dimensions required for manufacturing purpose conform to the dimensioning standards covered in the manufacturer's drafting conventions.

Reference dimensions reflect data needed to ascertain vertical space occupied by equipment units in frames, or overall dimensions of equipment frames or framework likely to be needed in determining building space requirements for installation of equipment. When applicable, the term "REF" follows the

dimension shown in the assembly layout. Reference dimensions shown for the above purposes are indicated in feet, inches, and fractions of an inch.

On the equipment assembly layout, in addition to the dimensions required for manufacturing or reference purposes, vertical distances in terms of occupied mounting plate unit spaces are to be shown as follows:

- On the frame assembly of equipment units, the vertical distance is determined from the floor level.
- On the assembly of individual equipment units, the vertical distance is the overall vertical mounting space required for the unit.

8. Component Identification

Components which enter into an assembly may be identified in the assembly layout as follows:

- **List or Group Designations:** On drawings containing stocklists ordering assemblies by lists or groups, if an assembly layout ordered by a mainlist or group includes other components or parts ordered by supplementary or alternate lists or groups, then these other components or parts are identified by their associated supplementary or alternate list or group. The designations, for example: L 4, or GR 3, precede the identification of the component or part shown in the assembly layout. Identification of components ordered by supplementary lists or groups is not indicated in assembly layouts of mounting plates.
- **Name or Description:** The name or description of the item always follows the number identification of the part, and is shown as follows:
 - **Assembly with stocklist:** Unless otherwise specified, the name or description is shown in the simplest form, usually as the single word noun name. Full names or descriptions are covered in the stocklist.
 - **Assembly without Stocklist:** Name or description is the same as would normally appear for listing the item in a stocklist.
 - **Coded apparatus** is identified by code number.
 - **Subassemblies** are identified by drawing number, and list, group, or detail number.
 - **Other manufacturer's components** are identified by the supplier's part number and supplier's name.
 - **Raw material** is identified by description.

Specify fastening devices in assembly layouts from the top-down in the order of assembly used in manufacturing or field assembly.

It is necessary only to show the center line of the assembled fastening device seen in end views, or by the conventional cross lines (+) in a plan view.

Screwhead side is conveyed by the use of the qualifying note - HEAD ON FAR SIDE.

9. Equipment Assembly - Main View

Assembly with Stocklist: Showing the main view on Sheet 1 depends entirely upon the space available on the sheet. The appearance of the stocklist, notes, and supplementary information tables, and the provisions made for expansion of these types of information usually dictate showing the main view on a supplementary sheet of the drawing. Supplementary views are shown on the same sheet containing the main view or on subsequent sheets of the drawing as required. Figure 3-I, represents the general arrangement of information shown on assembly drawing Sheet 1.

Figure 3-I General Layout - Equipment Assembly With Stocklist

Main View: Depending upon the design covered, the main view may include a complete frame assembly or a mounting plate or chassis-type unit assembly.

- Complete Frame Assembly: Refer to Figure 3-M for a sample layout of this assembly.
- Chassis-Type Unit Assembly: Refer to Figure 3-N for a sample layout of this assembly.

- Mounting Plate Unit Assembly: Refer to Figure 3-P for example layout of this assembly.

Assembly without Stocklist: The main view is shown on Sheet 1. If required, supplementary views also appear on Sheet 1 or subsequent sheets. Figure 3-Q represents the general arrangement of information on Sheet 1. Refer to Figure 3-R for a sample layout of a main view.

10. Components-General

For the purpose of identifying components on drawings the following factors should be considered:

- Surface-Mounted Type: These are screw-fastened, lug-fastened, and nut-fastened components such as relays, inductors, stud-mounted capacitors or resistors, etc.
- Pigtail Type: These are fastened and supported by means of leads furnished with the component.

Figure 3-M Equipment Assembly Frame Layout - Main View (With Stocklist)

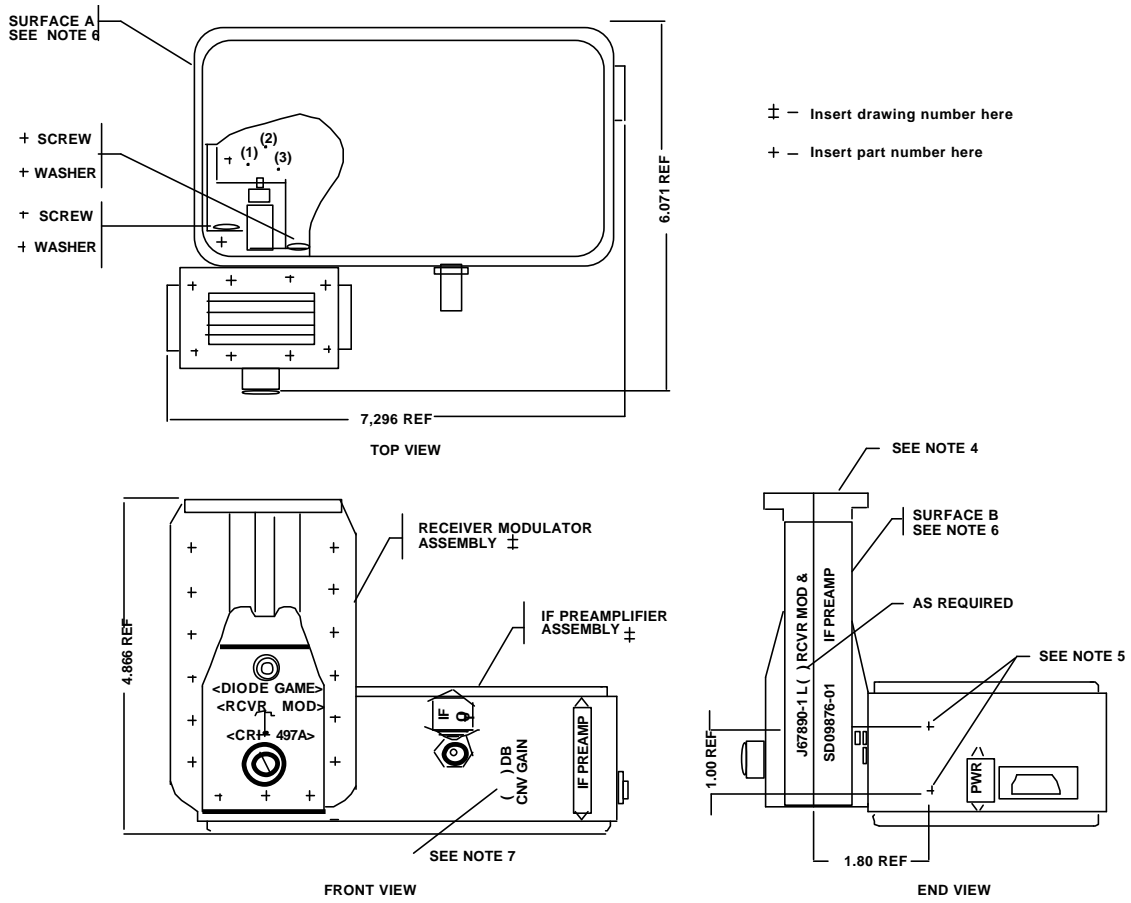

Figure 3-N Equipment Assembly, Chassis Unit-Main View (With Stocklist)

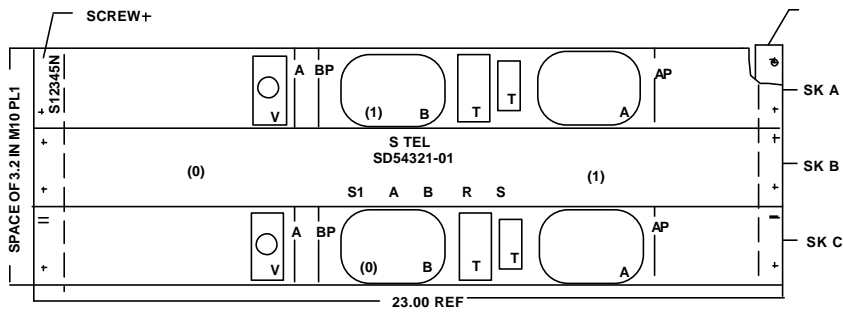

Figure 3-P Equipment Assembly, Mounting Plate Unit-Main View (With Stocklist)

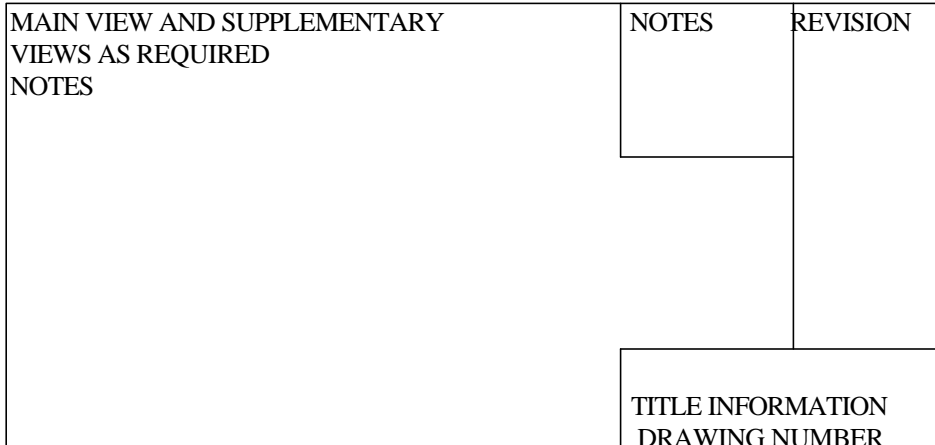

Figure 3-Q General Layout, Equipment Assembly Without Stocklist

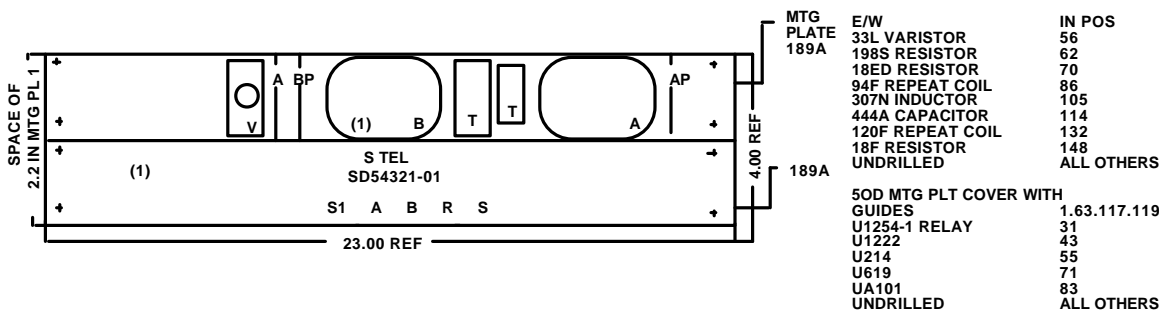

Figure 3-R Equipment Assembly, Mounting Plate Unit - Main View (Without Stocklist)

- Location, Representation, and Identification Two methods, the position number or convention view, are used to indicate the location, representation, and identification of components in the assembly layout.
 - Position Number Method This method is based upon the established concept of assigning position numbers from left-to-right on the surface of coded mounting plates. Referencing to these position numbers provides for indicating the location, representation, and identification of components.
 - Convention View Method This method is applied when position numbers cannot be predefined on mounting surfaces such as chassis, panels, etc. In this case, the views of assemblies are shown incorporating the location, representation, and identification of components in the view.
- Application of Methods: The type of mounting surface governs whether the position number or conventional view method is used to indicate the location representation, and identification of components in assembly layouts.
- Mounting Surfaces: These may be either of the following two general types.
 - Mounting plates are manufacturers' coded items, and their standard design usually includes assigned position numbers on the surface for locating components.
 - Coded mounting plates without predefined positions may be assigned position numbers from left-to-right provided the assigned positions are located by dimensions and numbered in the assembly layout.
 - The position number method of referencing is generally used for indicating location, representation, and identification of components located on mounting plates.
 - Chassis, panels, and similar mounting surfaces are not usually designed with predefined position numbers, and it is not a general practice to assign position numbers on these surfaces. The convention view method is generally used for indicating location, representation, and identification of components located on chassis and similar mounting surfaces.
- Dimensional Mounting formation: Mounting information as to location or size of holes required for mounting the component is shown only when the component mounting is special and is not covered by any layout of holes information. A supplementary view as shown in Figure 3-S is the means of indication.

Figure 3-S Dimensional Information for Components Not Covered by Layout of Holes Drawing

Components should be drawn to scale, but generally no deliberate attempt is made to show exact differences in size among components, especially when the components are basically similar in shape or are functionally similar.

In representing components, all shapes are shown as simple geometric forms consisting of circles or rectangles as indicated in Figure 3-T.

- A circle is used when the component is nearly or exactly circular in shape, and a rectangle of appropriate size is used when the components are approximately rectangular in shape (see Figure 3-U).
- When it is necessary to indicate normal orientation, or a physical feature of the component, it is permissible to show the component pictorially in the most simplified manner, as for example, the resistor in Figure 3-V.

Figure 3-T Method of Representing Component Shapes

Figure 3-U Simplification of Component Shape Representation

Figure 3-V Method of Showing Normal Orientation of Component

Multiple Appearances: When a component or a group of components appear in multiples, the following apply.

- When components of the same code or type are mounted in line, only the first and last components of the group should be shown (see Figure 3-W).
- When there is a series of adjacent like circuits, the first and last components of the first and last like circuits only should be shown (see Figure 3-W).
- The first and last components or sets of components of end circuits should be indicated (see Figure 3-W).
- For components other than relays, when there is a wide difference in size between adjacent components such as for 437, 439, and 441 capacitors, conventions of varying size are shown (see Figure 3-X).
- When components are mounted in two or more horizontal rows on a single-row mounting plate, component symbols are shown in each component position (see Figure 3-Y).
- When mounting plates are equipped with common covers, components under the covers are not shown. Only the functional or reference designations in sequence of the position of the components under the cover are shown (see Figure 3-Z).
- For all unequipped "Drilled For" mounting plate positions on drilled-type mounting plates, the plus (+) symbol is shown on the front view of the mounting plate (Figure 3-AA). Where the components are arranged symmetrically across the plate, the symbol is shown only for the first and last circuits. On mounting plates arranged for two circuits only, positions for both circuits are shown.
- When unassigned (undesigned) and unequipped "Drilled For" positions occur under a common cover and there is no rear view shown, each of the positions is indicated on the front view of the cover with the (+) symbol. This symbol is shown in proper sequence in relation to the indicated functional or reference designations (Figure 3-Z). The object of the symbol indication is to facilitate rear stamping of the mounting plate when unequipped but "Drilled For" positions occur between equipped positions.

Figure 3-W Components of Same Type, Adjacent and Multiple Appearances

Figure 3-X Convention Size Variation, Components of Relatively Different Sizes

Figure 3-Y Components in Multiple Rows, Single Row Mounting

Figure 3-Z Components Located on Mounting Plate Under Common Cover

Components on chassis, panels, etc. are drawn to scale or as near to scale as possible. Components are treated individually, unless they are aligned and arranged similar to the arrangement of components on mounting plates, in which case the procedures for components on mounting plates apply.

The symbol for representing A-, B-, C-, or D-type jacks is a circle. Frames associated with these jacks need not be shown.

When three or fewer keys are shown, the symbol for the lever is indicated for all keys. When more than three keys are shown, the first and last lever of each group only is shown (see Figure 3-BB).

Figure 3-BB Method of Showing Keys

The circle is used as a symbol for a lamp. The lamp socket mounting angle is also indicated when necessary. Both code and color of lamp caps are shown, for example:

2H, LAMP CAP, RED

Terminal strips are shown with a dash line (vertical) approximately 1/8 inch long. If terminal groups are shown, the first and last terminal rows only of each group are shown (see Figure 3-CC).

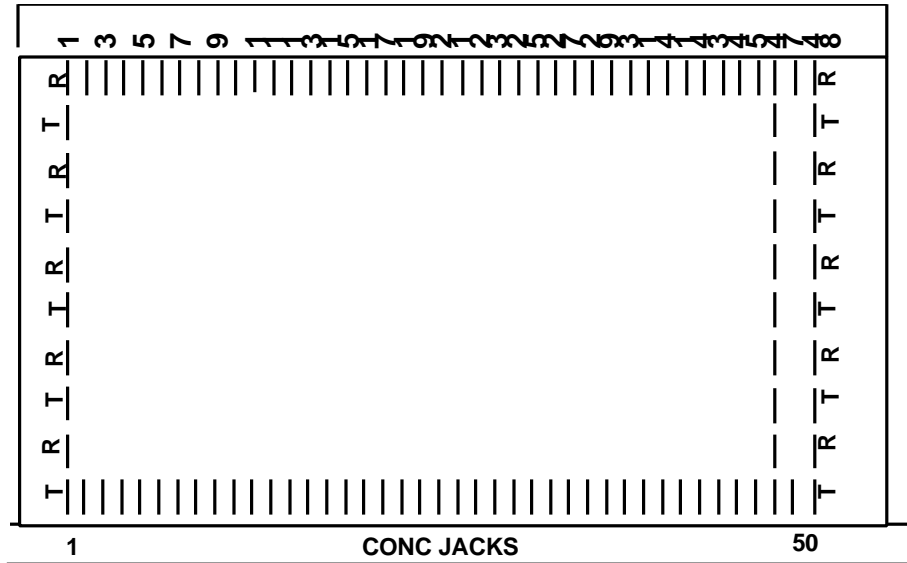

Figure 3-CC Method of Showing Terminal Strips and Terminals

In general, rear views of the assembly layout may be avoided by showing the component in place with dash lines in the front view to indicate that the component is located on rear.

Unless it is otherwise specified, component orientation corresponds to the normal horizontal and vertical positioning shown on layout of holes drawings. When it is necessary to indicate other than normal orientation, a supplementary view is used to indicate positioning of hole layout (Figure 3-DD). As an alternative, orientations may be conveyed in a note similar to the following:

ROTATE HOLE LAYOUTS FOR POSITION
() 30 DEGREES COUNTER-CLOCKWISE

Add the note under Manufacturing Notes on the drawing, and add a reference to the associated note number in the Stocklist Note column against the affected component.

Figure 3-DD Method of Showing Rotation of Component

A rear view is necessary when showing rear-mounted components if the front view interferes with information shown in the front view for components mounted on the front surface. Component locations cannot be expressed in terms of position numbers on chassis, panels, etc., and rear views are generally required. Rear views of mounting surfaces are shown by rotating the mounting plate, chassis, etc., 180 degrees in a left-to-right or right-to-left direction.

Markings are indicated on the component of the equipment side only. When components mount on both sides of the mounting plate, rear views are provided as required. Marking and stamping of components is determined by the manufacturer.

When the equipment unit includes a local cable assembly, the approximate cable path is indicated in one or more views with a path of cable line symbol. It may be necessary for mechanical reasons to specify paths for wires which would be otherwise run as surface-type wiring. Specification of wiring paths may arise, for example, from the need to keep wiring clear of movable parts, or to prevent wiring congestion. Instructions for running the wires should be covered in a manufacturing note, if possible, for example:

DRESS WIRES AT REAR OF PANEL TO
CLEAR 453 NETWORK WHEN INSERTED.

If a note is not adequate for conveying such requirements, the wire paths may be shown on an equipment view with a path of cable line symbol designated.

The method of indicating paths for pigtail leads is the same as described for wiring.

Position, representation, and identification of surface-mounted components is shown as follows.

Indicate position location as follows:

- Mounting Plates: The position number method is applied as follows:
 - Assembly with Stocklist-The position location is shown in the stocklist.

- On mounting plates having predefined position numbers, omit showing the position number of the component in the assembly layout.
- On mounting plates without predefined position numbers, if assigned, show the position number of the component in the assembly layout.
- Assembly without Stocklist-The position numbers of components are shown adjacent to the listed components in the assembly layout (Figure 3-R).
- Chassis, Panels, etc.-The surfaces are not designed to identify location of components by position number.
- Components are represented in assembly layouts as follows.
 - Mounting Plates: Components are shown individually with a simplified convention of the component shape.
 - Chassis, Panels, etc.: Components are shown in the simplest outline of their physical shape omitting or minimizing specific details. In all cases where the component is shown in the assembly layout, the component is accompanied by its functional or reference designation shown in brackets [] within or adjacent to the component convention.
- Components are identified by code or part number, name, and the supplier's name. Identification may also include functional or reference designations and associated circuit numbering.

Mounting Plates: Identification is shown as follows:

- Assembly With Stocklist-Identification by code or part number and name is shown in the stocklist.
- Identification in the assembly layout is limited to functional or reference designations and associated circuit numbering.
- Assembly without Stocklist-Identification by code or part number and name is listed adjacent to the assembly layout (Figure 3-R). Identification by functional or reference designation and circuit number is shown in the assembly layout. The order of listing components is as follows:
 - Surface-mounted components, arranged numerically according to the position number equipped.
 - Pigtail components
 - "Drilled For," but unequipped positions.
- Chassis, Panels, etc.-Identification by code or part number, name, functional designation and circuit number is shown in the assembly layout. When the

same component appears more than once, a single identification by code or part number, and name is sufficient.

Position, representation, and identification of pigtail components is shown as follows.

- Due to their method of mounting, indicating the location of pigtail components by position number is not applicable in assembly layouts. However, position location can be accomplished by association with the respective surface-mounted component to which the pigtail component is fastened, or by representation or identification of the component.
- The component may be shown in the front view (as rear-mounted) or in a rear view, depending upon which view will best serve to represent the assembly layout. Components shown in assembly layouts do not convey positional requirements.
 - Mounting Plate Assembly with Stocklist: On these drawings, the pigtail component is omitted from the assembly layout when a Pigtail Component Location-Mounting Plates Table is shown on the drawing.
 - Electrical Positional Requirements: Electrical positional requirements involving pigtail components are shown for maintenance reasons only on the wiring diagram drawing. In these cases, add a note reference to the wiring diagram drawing similar to the following under Manufacturing Notes on the assembly drawing. In place of the parentheses in the note, show the functional or reference designations of the affected components.

PIGTAIL COMPONENTS () ARE AS SHOWN ON T-

The above note is altered and shown in accordance with the following example, where in the absence of a wiring diagram drawing, the electrical positional requirements are shown in wiring figures included on the assembly drawing.

PIGTAIL COMPONENTS () ARE AS SHOWN IN FIG.

- Components are identified by functional or reference designations and code or part number, and supplier's name.
 - Functional or Reference Designations: In all cases where the component is shown in the assembly layout, the component is accompanied by its functional or reference designation shown in brackets [] within or adjacent to the component convention.
 - Mounting Plates: Identification is as follows.
 - Assembly with Stocklist-If the components are listed in a Pigtail Component Location-Mounting Plates Table, complete identification is covered between this table and the stocklist. If the components are not

listed in the table, the components are identified by a functional or reference designation in the assembly layout.

- Assembly without Stocklist-Identification by code or part number, and name is listed adjacent to the assembly layout (Figure 3-R). In addition, show functional or reference designations in brackets [] and electrical values of components.
- Chassis, Panel, etc.: Full identification is shown in the assembly layout if the assembly drawing does not include a stocklist, or a Pigtail Component Identification Table.

Equipment Partial Assembly Partial assemblies consisting of electrical components are always described on the assembly drawing.

Wiring Information: When wiring information is to be included on the equipment assembly drawing because of the absence of a wiring diagram drawing, refer to paragraphs on wiring diagrams contained herein for the applicable conventions to be followed in showing the wiring information.

Framework Assembly: In general, the main view of the assembly layout is shown in the lower-left corner of the drawing, which provides space both above and to the right of the view to show supplementary views as required. The main view appears on Sheet 1 providing the view does not interfere with the drawing space required for showing the stocklist or notes. If there is insufficient space on Sheet 1, show the assembly layouts on supplementary sheets of the drawing in the same manner as described above. Figure 3-EE represents the general arrangement of information shown on Sheet 1.

Figure 3-EE General Layout - Framework Assembly Drawing

1. General

This Section covers the requirements for the preparation and maintenance of the stocklist shown on assembly-type drawings of telephone equipment products. The requirements apply to all assembly drawings containing stocklists. The stocklist format has been standardized for the purpose of uniformity in its preparation and maintenance regardless of the sheet size and format of the drawing on which it is shown, and to provide for uniform interpretation of information to meet the needs of the drawing users.

For the general requirements to be followed in preparing stocklists on assembly drawings, see dimensioning details for the basic standard stocklist formats covered in this Section are reflected in the representative figure of each particular format. In addition to dimensioning details, each representative stocklist format includes in the figure, circled information indicating the maximum number of characters that can be entered in the columns based upon typewriter lettering of 10 characters per inch.

The stocklist is not a "table," and is not assigned a designation. The stocklist is a list of material and is not intended to be a source of reference for the selection of features of design, or for the manufacture, assembly, installation, or maintenance of the feature.

The stocklist is always required on an assembly drawing where provisions for listing of assemblies, units, subunits, components, parts, fastening devices, etc., for the selection of items are required in the manufacture or assembly of the design covered by the drawing. The assembly drawings on which the stocklist is shown are those drawings which convey both engineering and manufacturing requirements. These drawings fall under the following two general categories.

- Equipment-type assembly covers equipment designs of "wired" or "nonwired" units or subunits.
- Framework-type assembly covers structural or mechanical designs having no "wired" parts and intended for use in the mounting of or support for equipment units or subunits.

2. List and Group Designations

On assembly drawings, the list or group designation represents an assembly, unit, subunit, component, part, or a combination of items required for the assembly of the design covered by the drawing.

- Equipment-type assembly: Either list or group designations are used. A combination of both should not be used on the same drawing.
- Framework-type assembly: Only group designations are used.

- List Designation: Lists are designated either by number or letter, i.e.: List 1, List A, List WA.
- Group Designation: Groups are designated by number or letter, i.e.: Group 4, Group B, Group WC.

3. Equipment - Type Assembly

Format, location, and growth of a stocklist on an equipment-type assembly drawing are in accordance with the following.

- The basic format is as shown in Figure 4 - A

Figure 4 - A Stocklist Format - Equipment - Type Assembly Drawing

- The initial stocklist is shown on Sheet 1 of the drawing beginning in the upper left-hand corner of the sheet, or as determined by the manufacturer.
- Growth is from the top-down. When required, continuance of the stocklist should be as follows.
 - Additional stocklists may be shown adjacent to, and to the right of the previous stocklist. All adjacent stocklists have one common title band (see Figure 4-B).
 - Additional stocklists are not shown on Sheet 1 if it necessitates showing other information tables on a supplementary sheet of the drawing. In this case, the stocklist is continued on Sheet 2 of the drawing and shown according to the arrangement covered in Figure 4 -B.

Figure 4-B Stocklist Continued - Equipment-Type Assembly Drawing

- If the stocklist appears on two or more sheets, the sheets containing the stocklists should be consecutive. Directly below the end of the last stocklist on each sheet, it should be indicated on which sheet the stocklist is continued, for example: STOCKLIST CONTINUED ON SHEET 4.
- On Sheet 2 and subsequent sheets containing stocklists, the title band of the stocklist indicates its continuance, for example: STOCKLIST CONTINUED.

4. Framework - Type Assembly

Format, location, and growth of a stocklist on a framework-type assembly drawing are in accordance with the following.

- The basic format is as shown in Figure 4-C.

Figure 4-C Stocklist Format - Framework-Type Assembly Drawing

- The initial stocklist is shown on Sheet 1 of the drawing beginning in the lower-right corner above the Engineering Note field and to the left of the title box.
- Growth is shown from the bottom-up for stocklist items, and from right to left for groups and features. On Sheet 1, growth from bottom-up is limited to provide space across the top of the sheet required to show manufacturing notes or the continuance of engineering notes. Growth from right to left is limited only by the border on the left side of the sheet.

The size of the stocklist depends upon the number of horizontal lines required for stocklist items, and the number of vertical columns required for groups and features. When abnormal requirements exist for either of these conditions, continuance of the stocklist can be avoided by considering the following.

- When an abnormal number of horizontal lines is required, utilize the standard drawing form which provides for showing the maximum number of lines between the top and bottom borders of the sheet. Show all manufacturing notes and the continuance of engineering notes down the left

side of the sheet, and utilize the space usually reserved for these notes along the top of the sheet to show additional lines in the stocklist.

- When an abnormal number of vertical columns are required, utilize the standard drawing form which provides for showing the maximum number of columns between the right and left border of the sheet. Avoid showing any assembly layouts on Sheet 1, and instead, utilize the space to show additional column in the stocklist.

If continuance of the stocklist is found to be unavoidable, the following is recommended.

- If the number of stocklist items exceeds the limits of the initial stocklist and space is available, it is preferable to show a second stocklist on Sheet 1. The alternative is to show the second stocklist on Sheet 2.
- If a second stocklist is added, indicate directly above the initial stocklist, that it is continued, for example: STOCKLIST CONTINUED ON THE LEFT. In the title band of the second stocklist, indicate its continuance, for example: STOCKLIST CONTINUED.
- If the second stocklist is added on Sheet 2, on Sheet 1 directly above the stocklist, indicate that it is continued, for example: STOCKLIST CONTINUED ON SHEET 2. In the title band of the stocklist on Sheet 2, indicate its continuance, for example: STOCKLIST CONTINUED.
- If the number of groups and features exceeds the limits of the initial stocklist, the stocklist is continued on Sheet 2.
- On Sheet 1, in the column heading below the groups and features, indicate that these items are continued, for example: FEATURES AND GROUPS CONTINUED ON SHEET 2.
- On Sheet 2, in the column heading below the groups and features, indicate the continuance of these items, for example: FEATURES AND GROUPS CONTINUED.

5. List or Group Entries

Equipment-Type Assembly: Entry is only the number or letter portion of the list designation (see Figure 4-D). Different lists may be grouped as a single entry against an item, if the quantity of the item is the same for all lists. When grouped, lists are shown sequentially with numbered lists followed by lettered lists, and a comma separating each list (Figure ~D). The standards applying to lists also apply when group designations are used.

Framework-Type Assembly: The column used for group entries is also used to describe the feature that is provided by the particular group, and to show the status of the group if it differs from the status of the drawing as a whole.

- Individual columns are used for each group and associated feature description. Columns are designated 1A, 2A, 3A, etc. progressing from right to left. When the stocklist is continued on the same or another sheet, each group designation carries the same column designation as shown for the particular group in the initial stocklist.
- Group entries are shown as: GR1, GR2, GR A, etc.
- Feature entries consist of an adequate, but concise description of the item furnished by the group, and when necessary, any provisions for selecting the feature.
- In the box directly below the group entry, the rating of the group is entered, provided the rating of the group differs from the rating of the drawing as a whole. When shown, the rating is entered using standard 1/8 inch high lettering.

Figure 4-D Stocklist - Equipment Type - Assembly Drawing - Description Entries

6. Quantity Per List or Group Entries

Equipment-Type Assembly: Entry is the quantity of each item required per the list shown in Figure 4-D. The standards applying to lists also apply when group designations are used. A list may reduce or eliminate the quantity of an item furnished in other lists in the same stocklist if the affected lists are interdependent and are to be ordered together. In these cases, the term "OMIT" precedes the quantity against the item to be reduced or eliminated.

Framework-Type Assembly: The quantity per group column is an extension of the specific feature and group column. The quantity of each item required per group is entered in this column against each item in the group. A group may reduce or eliminate the quantity of an item furnished in other groups in the same stocklist if the affected groups are interdependent and are to be ordered together. In these cases, the term "OMIT" precedes the quantity against the item to be reduced or eliminated.

7. Identification Number Entries

Equipment- or Framework-Type Assembly: Entries are as follows, and as shown in Figure 4-D.

- **Drawing Number and Associated List, Group, or Detail Number:** This entry includes the following items.
 - Equipment assembly, unit, subunit, component, or part ordered by list or group on the manufacturer's other drawings.
 - Framework assembly, subassembly, part, or detail ordered by group or detail number on other of the manufacturer's drawings.
 - Local cable ordered by the manufacturer may or may not be ordered by group number.
- **Entries:** The complete entry in this column consists of the drawing number and associated list, group, or detail number. If the quantity of each is identical, a number of lists or groups from the same drawing may be combined as a single entry, and it may be necessary to use more than one line to make the complete entry.
- **Items Ordered by Another Drawing:** When the stocklist entry is an item ordered by another drawing, and that drawing carries an engineering note specifying additional material then the assembly drawing refers to the engineering notes on the other drawing.

8. Description Entries

All stocklist items on assembly drawings have an entry in this column, and the description is the name of the item. The description may also include special features, such as physical characteristics, electrical values, units of measure, or assembly information (Figure 4-D or 4-E).

Figure 4-E Stocklist - Framework Type Assembly Drawing - Description Entries

With the exception of the name of the item, standard abbreviations or symbols may be used for description entries. In the case of names of items, the following apply.

- No abbreviation is used when the name of the item consists of one word.

The following applies when the name of the item consists of two or more words:

- **Principal Noun:** No abbreviations are used; see the following examples.
- **Two Word Name:** It is preferred that abbreviation of the modifier of the principal noun be avoided. However, the standard abbreviation of the single-word modifier may be used for the purpose of consistent use of abbreviations in the same stocklist when the same abbreviation occurs in name phrases of three or more words (see the following examples).
- **Three or More Words, or Two Words and Number Name:** The standard abbreviations may be used for the modifying word or words of the principal noun, provided there is no loss in clarity by abbreviating the modifying words (see the following examples).

EXAMPLES:

For the purpose of identification only in the following examples, modifiers are shown in lower case and the principal noun is shown in upper case letters.

	<u>UNABBREVIATED FORM</u>	<u>ABBREVIATED FORM</u>
One Word	RESISTOR base ASSEMBLY	RESISTOR base ASSEMBLY
Two Words	cable CLIP terminal STRIP mounting PLATE	ca CLIP term. STRIP mtg PLATE
Two Words and Number	resistance LAMP 12,16 terminal PUNCHING 2R, 4R	res LAMP 12,16 term. PUNCHING 2R, 4R
Three Words	mounting plate COVER cable rack ASSEMBLY	mtg plt COVER ca rk ASSEMBLY

Stocklist items are grouped by type of item described and listed in the following table. The order of sequence for listing the item-groups in the stocklist is shown in parentheses.

- **Equipment-Type Assembly Stocklist:** The order of sequence is listed top-down.
- **Framework-Type Assembly Stocklist:** The order of sequence is listed bottom-up.
- **Spacing of Item-Groups:** The minimum recommended space shown after each item-group is at least two blank lines.

- Fastening devices such as, screws, nuts, washers, etc., are described in the following sequence: principal noun name of part, modifier, and as required: thread, length, thickness, diameter or finish.

EQUIPMENT ASSEMBLY-TYPE STOCKLIST		FRAMEWORK-TYPE ASSEMBLY STOCKLIST
WITH FRAMEWORK UNIT	SUBUNIT ASSEMBLY ONLY	
(1) Frame work units or item, partial assemblies, and mounting details (2) Local cable & local cable items, batteries (3) Terminal strips (4) Equipment subunit assemblies (5) Surface-mounted components (6) Pigtail components (7) Equipped mounted plates (8) Fastening devices (9) General use items, P—or COMCODE numbered piece parts spare parts (10)Other supplier items	(1) Chassis, printed wiring boards, panels, etc. (2) Partial assemblies (3) Mounting details All other item-groups shall follow sequence arrangement shown in column on the left	(6) Other supplier items (5) General use items, P-or COMCODE numbered piece parts (4) Fastening devices (3) Details (2) Partial assemblies (1) Framework units

Description and sequence consist of apparatus code number, name of apparatus, and any electrical values.

Description and sequence consist of the name of the item, special features, supplier's catalog number, and supplier's name and location (city and state). Location of supplier is generally necessary when the item must be obtained directly from the supplier at a specific location.

When design requirements specify that the notation "or equivalent," this notation in the abbreviated form OR EQUIV is entered in the description column following the description of the affected item.

When batteries are components of an equipment assembly, the following apply.

- Dry-type batteries are not listed in the stocklist because of the possibility of deterioration during storage in the event that the equipment is manufactured and stored as a stock item. When dry batteries are required, the battery requirements are covered in an engineering note on the drawing.
- Storage-type batteries may be listed in the stocklist. However, they are treated as parts not assembled, but shipped separately, and a reference to the appropriate assembly and shipping information note is shown in the Stocklist Note column against the battery item.

9 Note Entries

Equipment- or Framework-Type Assembly: The Note column is subdivided into two columns, as shown in Figure 4-A or 4-C, and entries are made as follows.

- In column E of Figure ~A or column D of Figure 4-C, the entry is letter-or symbol-designated types of notes, which generally are assembly or shipping information notes.
- In column F of Figure ~A or column E of Figure 4-C, the entry is numbered note references.
- Both columns are utilized when an assembly or shipping note reference is represented by a double rectangular-shaped symbol.

Specific notes are used to provide assembly and shipping information for either individual or all stocklist items. When used, these notes are the first of the group of notes initially listed under Manufacturing Notes on the drawing. Symbols or letter designations associated with the notes also appear in the stocklist t in the appropriate note column against the item affected.

The notes covered in this part occur with sufficient frequency on drawings to warrant standardization of their expression and to obtain uniform interpretations of their application by all drawing users. Modification of the standard expression is not permissible, unless agreements have been reached in each application with the location controlling manufacture of the equipment in order to satisfy some specific shipping or assembly requirement.

In addition to notes, standard symbols have also been adopted for use in connection with the notes. In the manufacturing notes, the form used for representing the rectangular-shaped symbols, associated with the notes covered in the following paragraphs is as shown in Figure 4-F. Lineweights should be thin lines.

Figure 4-F Drawing Standard - Note Symbols

In the Stocklist Note column, show the "strike," "asterisk," and "spare" marks within the boundaries of the Note column.

Stocklist items have been designated in four categories covered in the following paragraphs to identify the application of the proper shipping or assembly information. Each category is accompanied by explanatory conditions followed by the applicable standard note to be used.

Designation of All Stocklist Items: This category includes all stocklist items to be treated as follows.

- All items are to be assembled by the shop and are shipped fully assembled. This applies to all items in the stocklist, and no reference to the applicable note is required in the stocklist. No other general assembly or shipping information note is shown on the drawing. Show the following note on the drawing.

ALL PARTS TO BE ASSEMBLED FOR SHIPMENT.

- All items are to be assembled for fit by the shop and then dismantled, and all items are shipped separately. This applies to all items in the stocklist and no reference to the applicable note is required in the stocklist. No other general assembly or shipping information note is shown on the drawing. Show the following note on the drawing.

ALL PARTS TO BE ASSEMBLED FOR FITTING AND DISASSEMBLED FOR SHIPMENT.

- None of the items are to be assembled by the shop, and all items are to be shipped separately. Applies to all items in the stocklist, and no reference to the applicable note is required in the stocklist. No other general assembly or shipping information note is shown on the drawing. Show the following note on the drawing.

ALL PARTS TO BE SHIPPED SEPARATELY.

Designation of Individual Stocklist Items: This category excludes fastening devices such as, screws, nuts, washers, etc., used for assembling or mounting apparatus components, equipment units on subassemblies, or for erecting or aligning framework assemblies, and they are treated as follows.

- Individual items that are not to be shop-assembled with other stocklist items and not associated with other shipped shop-assembled items, but are to be shipped separately. Show the following letter designation and note on the drawing, and an "S" in the Stocklist Note column against the affected item.

S - PARTS NOT ASSEMBLED, SHIPPED SEPARATELY

- Individual items that are part of a particular assembly, but are field-assembled. When shipped for field assembly, the individual item is associated with the particular shop assembly and is not shipped separately. Show the following symbol and note on the drawing, and the symbol in the Stocklist Note column against the affected item. Commonly referred to as an "asterisk" item.

PARTS TO BE SHIPPED ATTACHED TO, OR ENCLOSED IN THE SAME CONTAINER WITH THE ASSOCIATED ASSEMBLED ITEM.

- Individual items that are part of a particular assembly, and the individual item is either shop-or field-assembled. When shipped for field assembly, the individual item is associated with the particular shop assembly and is not shipped separately. Show the following symbol and note on the drawing, and the symbol in the Stocklist Note column against the affected item. Commonly referred to as "asterisk" items.

PARTS (A) REQUIRED FOR MANUFACTURE WHEN EQUIPMENT INVOLVED IS SHOP-MOUNTED, OR (B) TO BE SHIPPED ATTACHED TO, OR ENCLOSED IN THE SAME CONTAINER WITH THE ASSOCIATED ASSEMBLED ITEM WHEN FIELD-MOUNTED.

Designation of Individual Stocklist Items to be Assembled Only When the Final Assembly of all Items is Being Made: Prevents assembling of certain items which later would have to be dismantled in order to assemble associated items in the final assembly. These items are treated as follows.

- Items furnished are either shop or field-assembled, but cannot be assembled until other contingent items are also included at the time of assembly. Such items that cannot be initially assembled also include fastening devices such as, screws, nuts, washers, etc. directly associated and specifically required to assemble or mount the basic item. Show the following letter designation and note on the drawing, and a ~ in the Stocklist Note column against the affected item.

W- PARTS ASSEMBLED AT THE SAME TIME THE EQUIPMENT IS MOUNDED

- Individual items that are part of a particular assembly, and the individual part is either shop- or field-assembled, but the particular assembly cannot be assembled until other contingent items are also included at the time of assembly. When shipped for field assembly, the individual item is associated with the particular shop assembly and is not shipped separately. Show the following letter-symbol designation and note on the drawing, and a "W*" in the Stocklist Note column against the affected item.

W*- PARTS TO BE (A) SHOP-ASSEMBLED, BUT WHICH CANNOT BE ASSEMBLED UNTIL THE ASSOCIATED EQUIPMENT IS BEING MOUNTED, OR (B) SHIPPED ATTACHED TO, OR ENCLOSED ~ THE SAME CONTAINER WITH THE ASSOCIATED EQUIPMENT WHEN FIELD-MOUNTED.

Designation of Fastening Device Items such as Screws, Nuts, Washers, etc.: This category excludes such screws, nuts, washers, etc. that are designated by a "~"

note, or are designated as "asterisk" or "asterisk spare" items, and they are treated as follows.

- Items furnished are for field assembling or mounting apparatus components, equipment units or subassemblies, or for erecting or aligning framework assemblies. Show the following symbol and note on the drawing, and the symbol in the Stocklist Note column against the affected item. They are commonly referred to as "strike" items.

PARTS REQUIRED FOR INSTALLATION

- Items furnished are for shop or field assembling or mounting apparatus components, equipment units or subassemblies, or for erecting or aligning framework assemblies. Show the following symbol and note on the drawing, and the symbol in the Stocklist Note column against the affected item. Commonly referred to as "strike spare" items.

PARTS REQUIRED FOR MANUFACTURE WHEN EQUIPMENT IS TO BE
SHOP-MOUNTED, OR BY THE INSTALLER WHEN EQUIPMENT IS TO BE
FIELD-MOUNTED.

10. Line Number Entries

Line numbers are assigned consecutively to all lines in the stocklist, including lines in which no stocklist information entry is made. However, every stocklist line is not actually numbered. Line numbers are only shown in the first line, fifth line, and every fifth line thereafter.

Equipment-type assembly line numbering is as follows:

- On Sheet 1 of the stocklist line numbers begin with the number 101.
- On Sheet 2, 3, etc. of the stocklist line numbers begin with the next highest hundred group that succeeds the numbering group used on the preceding sheet, for example:
 - If line numbering on Sheet 1 is from 101 to 235, then line numbering on Sheet 2 should begin with 301.
 - If line numbering on Sheet 4 is from 501 to 605, then line numbering on Sheet 5 should begin with 701.

Framework-type assembly line numbering is as follows:

- On Sheet 1 of the initial stocklist the line numbers begin with the number 101.
- Regardless of whether the stocklist is continued on Sheet 1, Sheet 2, etc., line numbering is as follows:
 - When the stocklist is continued, and all the stocklist items contained therein are identical to the initial stocklist items, then the line numbers associated with each item should also be identical in all appearances of the stocklist.
 - When the stocklist is continued to list additional items that are not included in the initial stocklist, then the line numbering in the continuation of the stocklist should begin with the next highest hundred group that succeeds the numbering group used in the preceding appearance of the stocklist. For example, if line numbering in the initial stocklist is from 101 to 148, then the line numbering in the continuation of the stocklist should begin with 201.

11. Surface Mounted Components

Listing and Grouping of Components: Surface-mounted components not listed under an "E/W" item are grouped together in the Description column of the stocklist, as covered in the following and Figure ~G.

- If more than one type of surface-mounted component is to be listed, the like components are subgrouped by name of component and listed in alphabetical sequence, with at least two blank lines left after each subgroup.
- When the surface-mounted components are of a single type, the subgroup arrangement is also followed in listing the components.

Figure 4-G Listing of Surface-Mounted Components Not Associated With an E/W Item

12. Pigtail Components

A pigtail component is supported by leads which are part of the component. Due to this method of support, it is difficult to identify by position number the exact location of the component. However, since the component is assigned a reference designation and is electrically associated with a surface-mounted part on chassis-or mounting plate-type equipment, the following methods are used for listing pigtail components in the description column of the stocklist.

Since it is anticipated that the manufacturer's component-mounting details will have no standard readily identifiable component locations, it is recommended that reference or functional designations be assigned to each component of an assembly and this type of stocklist be part of the manufacturer's assembly drawing. This will enable the Telco's maintenance forces to identify the components on the assembly and will provide component values for replacement purposes (see Figure 4-H and 4-J).

If more than one type of pigtail component is associated with a chassis unit or mounting plate, the like components are subgrouped by name of component and listed in alphabetical sequence.

When the pigtail components are of a single type, the subgroup arrangement is also followed in listing the components.

If an electrical value is a required part of the ordering information, the value is shown following the name of the component. When a number of components are shown one after another, the electrical values are shown vertically.

Figure 4-H Listing of Pigtail Components Associated With An E/W Mounting Plate

Figure 4-J Listing of Pigtail Components Associated With a Chassis-Type Unit

The pigtail or other component reference designation entry is shown in brackets following the electrical value, if this value is shown; otherwise, the designation follows the name of the component. When a number of components are shown one after another, the reference designations are aligned vertically.

If pigtail components are listed, one of the following methods is used in the stocklist.

- Mounting Plate-Type Equipment (Pigtail Component Location-Mounting Plates Table Used): All pigtail components associated with a particular mounting plate are listed under that mounting plate item with a reference to the associated location table (see Figure 4-H).
- Chassis Type-Equipment (Pigtail Component Identification Table Used): All pigtail components associated with chassis-type equipment are grouped and listed together in the stocklist (see Figure 4-J). When the group is divided into subgroups, at least two blank lines should be left after each subgroup.

When a pigtail component location-mounting plates table or pigtail component identification table is not shown on the drawing, all pigtail components are grouped and listed together in the stocklist (Figure 4-J). If this group is divided into subgroups, at least two blank lines are left after each subgroup.

13. Mounting Plates - Equipped

All mounting plates to be equipped with other parts are grouped together and shown one after another in the description column of the stocklist as covered in the following.

- Each mounting plate is treated as an individual subgroup. The mounting plate is referenced to the assigned sketch designation, i.e., SK A, SK B, etc.,

and the subgroups are listed in alphabetical sequence in accordance with the designated SK reference, Figure 4-K (a). At least two blank lines are left after each subgroup. In addition to the mounting plate, each subgroup consists of the components to be assembled on the mounting plate, including auxiliary mountings for components, and nonelectrical parts such as covers, cover guides, etc., which are listed in the stocklist to be assembled on the mounting plate.

Figure 4-K Listing of Mounting Plates Equipped With Components

- The equipped mounting plate position is shown in the description for the following items assembled on the mounting plate:
 - Position of each surface-mounted component
 - Position of each auxiliary mounting detail
 - Position of each cover guide of a common cover
- The mounting position entry follows the general description of the item, see Figure 4-K (b). The position entry for the first item listed under the mounting plate indicates IN POS followed by the position numbers. Subsequent items only indicate the position number, and the position entries for all items are aligned vertically. If a quantity of two or more of the same items is mounted on the plate, the position entries following the general description are in sequential order starting with the lowest numbered position. If required, successive lines are used to enter all the position numbers. The position of parts mounted on the rear of the plate is indicated by the position number suffixed with an "R."
- A surface-mounted component equipped with additional parts other than pigtail components is listed as follows. The surface-mounted component is listed with the entry E/W after the general description followed by its position number entry. The parts to be assembled on the component are listed as separate entries on successive stocklist lines without any mounting position entries; refer to 39A LP SKT item in Figure 4-K.

14 Fastening Devices

Fastening devices such as, screws, washers, nuts, etc. which have general application to the design covered on the drawing are grouped together and shown in the description column of the stocklist.

This assembly usually is a coded equipment consisting of an equipped unit, or equipped mounting plates or equipped panel having specific or universal application, but the stocklist of the equipment does not include the mounting framework. Fastening devices for mounting the equipment are ordered in the stocklist of the equipment on the following basis.

- If the equipment is designed for mounting on a specific known framework, provide the fastening devices required for the particular framework.
- If the equipment is designed to mount on optional types of framework, provide the fastening devices required for the optional mounting conditions.

When the stocklist includes both the equipment items and the framework for mounting the equipment, fastening devices required are ordered in the stocklist for all of the equipment items listed.

- When the method of fastening is by screw only and the equipment item is to be specifically shop-mounted only, the screws provided in the stocklist of the particular equipment item are utilized if satisfactory, or the shop automatically furnishes the appropriate screws. If it is optional for the equipment unit to be either shop- or field-mounted and the screws provided in the stocklist of the particular equipment item are not satisfactory, order the screws in the stocklist which includes the mounting framework.
- When the method of fastening is by screw, washer, and nut combination, in all cases, if the required fastening parts are not provided in the stocklist of the particular equipment item, order the screws, washers, and nuts in the stocklist which includes the mounting framework.

Fastening devices are ordered in the stocklist for all mounting plates or panels listed as individual items in accordance with the following.

- When the method of fastening is by screw only; if the plate or panel is to be specifically shop-mounted, the screws are automatically furnished by the shop and are not ordered in the stocklist. If it is optional for the plate or panel to be shop- or field-mounted, the screws are ordered in the stocklist.
- When the method of fastening the plate or panel is by screw, washer, and nut combination, in all cases; order the screws, washers, and nuts in the stocklist.

Only those fastening devices required in the assembly of framework items and associated items ordered in the stocklist are listed. Fastening devices for mounting items ordered in the stocklist of an equipment assembly drawing are not listed in the stocklist of the associated framework assembly drawing.

For the purpose of general maintenance of the stocklist and for recording revisions made, the following apply.

- Certain drawing revisions affect the drawing as a whole, and although stocklist information may be affected, these changes normally are not referenced as changes to the affected stocklist information. The following are examples of changes that normally affect the drawing as a whole, and for which references to the affected stocklist changes in these cases are omitted in recording the revision, Fig. ~L (a).

Figure 4-L Replacement of Apparatus for Interdependent List or Groups

- For the addition of new lists, groups, etc., reference in the revision note is made only to the new feature added.
- Change in status or rating of an existing list or group where it differs from the status or rating of as a whole; reference in the revision note is made only to the list or group and its change of status or rating.
- In general, no attempt is made to rearrange existing entries to add new entries. If the entries are grouped by type or in a specific sequence, to add new entries, use blank lines if available, at the end of the group or sequence. Otherwise, add the new entry after all previous entries.
- Unless otherwise specified, all line-outs are horizontal lines and a thin lineweight is used, Fig.4-L (b). Use of line-outs is limited to the following.
 - Line-outs are permissible for deletion of information to generally avoid lengthy revision notes. They are applicable when the information in all the column associated with the entry is to be deleted. The associated line number is not lined out.
 - Line-outs are permissible for changes in the stocklist which incorporate replacement of apparatus components or printed wiring assembly items.
- The following methods are applied in recording revisions made in stocklist information.
 - This method of reference utilizes STOCKLIST (SL), and depending upon the condition of change, the affected line number and/or column reference in accordance with the following sample conditions:

When an addition consisting of a new line entry is made, the reference in the revision note is made in accordance with the following examples:

SL LINE 210 ADD.
SL LINE 105 & 320 ADD.

When a deletion of a line is indicated by a line-out of a stocklist line in which the complete information is lined out, the reference in the revision note is made in accordance with the following examples:

SL LINE 210 CANC.
SL LINE 105 & 320 CANC.

When column references are made, if assigned, refer to the column designation; otherwise, refer to the column heading description in accordance with the following examples:

SL LINE 10, COL AE POS 10 ADD.
(Reference to column designation)
SL LINE 10, UNDER DESCR POS 10
ADD. (Reference to column heading)

- **Direct Reference to Column-Line Coordinate Designations:** This method of reference utilizes the stocklist column designations "A" to "F" and the associated line numbers. as coordinates to designate the column and line in which the change is made. 1~ order to avoid any possible conflict where the column-line coordinate designation may be identical al to or confused with alpha-numeric information in the associated graphics contained on the drawing, the designation "COL" prefaces the column-line coordinate designation in the revision note. Use of the column-line coordinate method is applied on equipment-type drawing stocklists providing all other tables on the drawing meet the condition for the use of the coordinate method referenced in Section V of this document.
- **Applications:** This method of reference is applied to changes affecting any column in the stocklist, in accordance with the following examples:

If column D in line 199 is changed, the reference in the revision note would be:

COL D119 READ_.

If columns B and D in line 115 are changed, the reference in the revision note would be:

COL B115 & D115 READ_&_RESP.

If only part of the information in column D in line 212 is changed, the reference in the revision note would be:

COL D12 _READ_.

If in an existing entry on line 125, an entry is made in column E in which no prior entry was shown, the reference in the revision note would be:

COL E125 ADD.

If entries are made in column F, in which no prior entries were shown for the entire column in the entire stocklist, the reference in the revision note would be:

COL F ADD.

- Framework Assembly Drawing Stocklist: All prior provisions covered in the preceding paragraphs also apply to the stocklist on framework-type assembly drawings. However, in the Feature and Group column, the column reference is as follows.
 - Feature and Group Column This column is subdivided as required for individual group entries accompanied by a description of the feature provided by the group. In order to conform with the general pattern adopted for applying column-line coordinate references, each column subdivision has been designated 1A, 2A, 3A, etc. in lieu of the designation A for the entire column field. On this basis of individual column designations, coordinate references are applied to changes affecting any subdivision column in the Feature and Group field of the stocklist in accordance with the following examples.

If in column 5A, the feature description is changed, the reference in the revision note would be:

COL 5A READ_.

If in column 3A, line 130 is changed, the reference in the revision note would be:

COL 3A130 READ_.

If in column 3A and 5A, line 130 is changed, the reference in the revision note would be:

COL 3A130 & 5A130 READ_&_RESP.

1. General

This Section covers the requirements for presenting engineering drawing information in tabular format. The requirements covered generally apply to all drawings. included are general requirements applicable whenever tabular formats are required irrespective of the type of drawing being prepared. In addition, for specific use with the equipment-type assembly and stocklist drawing covered elsewhere in this publication, this Section includes tabular formats which have been standardized for the purpose of uniformity in their preparation and maintenance regardless of the sheet size and format of the drawing on which they are shown, and to provide for uniform interpretation of the information in tabular form to meet the needs of the users of the drawing.

The following general requirements apply to the preparation of tabular forms of information shown on drawings.

- In general, tabular formats shown on drawings incorporate features as shown in Figure 5-A.

Figure 5-A General Tabular Format

- A column designation is shown for each column heading (excepting the Line column), which generally directly precedes the tabular information entries. Designations are alphabetic, i. e.: A, B, C, etc. If the tabular form is assigned an alpha table designation, the column designations are prefixed by the table designation, i e.: for Table X, the column designations are XA, XB, XC, etc. Column designations are utilized for reference purposes and in revision notes.
- Each type of drawing, i e.: wiring diagram, equipment-type assembly, etc., may have a group of tables peculiar to only that drawing. Depending upon the information conveyed by the drawing, only selected tables of the group may be chosen to be shown. For purposes of uniformity and identifying identical tables on various drawings of a particular type, the following standards are employed in the designation of tables.

- Unless otherwise specified, tables are designated using alphas "A" to "Z", with the exception of T and "O." Table designations are utilized for reference purposes and in revision notes.
- If not covered herein, refer to the specific part covering the standards for a particular type of drawing for the assignment of table designations to standard tabular formats peculiar to that drawing.

- All tabular formats show a title which briefly describes the informational content. ~ the tabular format carries a table designation, the title follows the table designation on the same line.
- The supplementary information heading field is optional and is used if it is necessary to include certain information which pertains only to the contents of the particular table.
- The column headings field is used to describe the informational contents of the specific columns. Column headings consist of one heading field above (or below depending on growth) another. The main field may contain a major heading which is followed by subheadings in the succeeding field.
- All lettering in tabular formats conforms with lettering standards considered appropriate by the manufacturer.

2. Repetitive Entries

In certain columns of tabular formats when consecutive entries are made and either all of the entries are identical, or a portion of each entry is identical, repetitive entries for the identical information may be avoided by employing the following methods.

- Blocking consists of showing the identical information only once in the column and omitting the segment of intervening horizontal lines that would otherwise be shown between each consecutive identical entry in the column. Blocking encompasses only consecutive entries containing identical information. Blank lines are not included
 - Blocking is recommended where the tabular format is not preprinted with horizontal linework for informational entries. N is generally used only when identical information directly relates to the following information in either the same column or in the succeeding columns (see Figure 5-B). Blocking may be used in the last column, i1~ identical information in that column affects all the entries in the preceding column. When applied to a portion of the information in the same column the column is subdivided by a vertical line. The left subdivision contains the portion of the information that is identical, and the right subdivision contains the balance of the information in all the associated entries that is not identical. If some of the related consecutive entries in the right subdivision are identical, these entries may also be blocked.
- A bracket consists of showing the identical information only once in the column, and is immediately followed by a short horizontal dash joining with a vertical line. The length of the vertical line is determined by the number of consecutive identical entries that would otherwise be shown in the column.

The bracket encompasses only consecutive entries containing identical information. Blank lines are not included.

1. The bracket is recommended where the tabular format contains preprinted horizontal lines for information entries, and it is neither desirable nor practical to erase the preprinted linework to employ blocking. It is used only when identical information directly relates to following information in either the same column or in the succeeding columns (see Figure 5-B). It may be used in the last column, if identical information in that column affects all entries in the preceding column. In this case the bracket is reversed, showing the vertical line first joining to the short horizontal dash, and followed by the repetitive informational entry. When applied to a portion of the information in the same column, the column is subdivided by a vertical line. The left subdivision contains the portion of information that is identical, and the right subdivision contains the balance of the information and the associated entries that is not identical. If some of the related consecutive entries in the right subdivision are identical, these entries may also be

Figure 5-B Method of Showing Identical Repetitive Entries

- A ladder consists of showing the identical information only once in the column, and is immediately followed by a short horizontal dash joining with a vertical line. The length of the vertical line is determined by the number of consecutive identical entries that would otherwise be shown in the column. In lieu of the repetitive entries, draw a short dash through the vertical line for each consecutive entry. The ladder encompasses only consecutive entries containing identical information. Blank lines are not included.
 - The ladder is used in the same manner as ditto marks might be applied, except that the information encompassed by a ladder does not directly relate to succeeding information in the entries. The ladder may be used in combination with either blocked entries or bracketed entries (see Figure 5-B).

3. Revision Recording (Drawing Issue Notes)

For purposes of recording changes in the revision note, tabular formats on drawings generally incorporate the assignment of line numbering and column designations. With the exception of the stocklist, all tabular formats prepared by current standards are assigned specific alpha designations, which in turn are reflected in the associated column designations, i.e., for Table X, columns are designated XA, XB, XC, etc. The stocklist is not classified as a "table" and therefore, is not assigned a letter designation, and the column-s are only designated A, B, C, etc. On drawings containing tabular formats which totally reflect the above conditions, maximum utilization of the unique identities of the tabular formats, column designations, and line numbering provides for avoiding redundant or repetitive references in recording changes in the revision notes.

Certain drawing revisions affect the drawing as a whole, and although tabular information may be affected, these changes normally are not referenced as changes to the affected tabular information. However, if these revisions result in changing other existing tabular information, then the other affected changed information is referenced as a change in tabular information. The following are examples of changes that normally affect the drawing as a whole, and for which references to the affected tabular formats in these cases should be omitted in recording the revision notes.

- On assembly drawings, for the addition on new lists, groups, etc., reference in the revision note is made only to the new feature added.
- On wiring diagrams, for the addition of new circuit features, reference in the revision note is made only to the new circuit feature added.
- Change in status or rating of an exiting list or group on assembly drawings, or circuit feature on wiring diagrams, where it differs from the status or rating of as a whole, reference in the revision note is made only to the list, group or circuit feature, and its change of status or rating.

Methods for recording revisions to the stocklist are covered in Section IV.

The tabular Sheet Index is an "index," is not classified as a "table," and is exempt from the following procedures.

Based upon the condition of change, references in the revision note are made by either direct or indirect reference to the table, and the affected line, or direct reference to tabular column-line coordinate designations, as covered in the following paragraphs.

The direct reference to table and affected Line or column method of reference utilizes the table designation and the affected Line number or column, and is applied for the following conditions:

- When an addition consisting of a new Line entry is made, i.e., line 12 added in Table X, the reference in the revision note is made as follows:

TBL-X LINE 12 ADD

- When a deletion of a line is indicated by a line-out of a table line in which the complete information is lined out, i.e., line 9 in Table X is lined out, the reference in the revision note is made as follows:

TBL-X LINE 9 CANC

Depending upon the condition of change, refer to the table, affected line number, and affected column designations as follows:

- Reference to the table is always required. If assigned, use the alpha designation rather than the title of the table.
- If the table does not carry line number assignments for entries, refer to information in the entry that is unique and easily distinguished from other entries in the table.
- If the table does not carry column designations, refer to the column heading description.

Direct reference to tabular column-line coordinate designations utilizes the column designations unique to each table and the associated Line numbers as coordinates to designate the column and line in which the change is made, and avoids referencing to the table designations in the revision note. In order to avoid any possible conflict where the tabular coordinate designation may be identical to or confused with alpha-numeric information in the associated graphics contained on the drawing, the designation "COL" prefaces the tabular coordinate designation in the revision note. Where exceptions in the procedures covered are involved due to a peculiar format arrangement of a table, the methods of referencing changes will be found in the paragraphs covering the particular table. Examples of the application of tabular column-line reference designations to changes in tables are as follows:

- Table-X Changes: Columns are designated XA, XB, XC, etc. and changes are:
It column XC in line 12 is changed, the reference in the revision note would be:

COL XC12 READ-

If column XE in lines 15, 18, and 21 is changed, the reference in the revision note would be:

COL XE15, XE18 & XE21 READ-, - & - RESP

If only part of the information in column XA in line 19 is changed, the reference in the revision note would be:

COL XA19- READ-

If in existing information in line 13, an entry is made in column XF in which no prior information was shown, the reference in the revision note would be:

COL XF13 ADD

If entries are made in column XH, in which no prior entries were shown for the entire column in the entire table, the reference in the revision note would be:

COL XH ADD

- Utilization of tabular column-line coordinate designations is applied to new and existing drawings if all of the tables excluding the stocklist and Sheet Index on the drawing meet all of the following conditions:

All tables should carry line numbering assignments for informational entries.

All tables should carry alpha designations.

All column designations in the tables carry over the table designation into the column designations.

The aforementioned conditions described in the previous paragraphs are only some examples for applying tabular column-line coordinate designations to changes made in tables. In actual application, the composition of the revision note using this form or any other form of reference is arranged and worded to assure clarity in interpreting the changes recorded.

4. Standard Tabular Formats

The following table, Standard Tabular Formats and Applications, is the list of standard formats covered in this Section and their general applications.

The distinction between the stocklist and tables is as follows.

- This tabular format is not classified as a "table." the stocklist is basically only a list of material and is not intended to be utilized as a primary source of reference for information required to determine either the selection of features of design covered by the drawing, or for the method of manufacture, assembly, installation, or maintenance of the feature. The stocklist is not assigned a "table" designation.
- These tabular formats convey various forms of reference information as required to assist in the selection of features of the design covered by the drawing, and their manufacture, assembly, installation, or maintenance. Tables are assigned "table" designations.

All standard tabular formats shown on assembly drawings, excepting the stocklist, are assigned specific alpha designations as indicated in the preceding list of standard formats for purposes of uniformity in presenting identical tables on different assembly drawings, and to provide the users of drawings with consistent table references.

- Standard designations are alphas "A" to "H" which have been assigned. Alphas "J" to "P" are reserved for assignment to any tables that may be adopted in the future as standard formats. Alphas T and "O" are not used.
- Tables covered in this part without an assigned alpha designation are assigned a designation from the alpha series "R" to "Z" as required.

- When conditions warrant showing a special table on the drawing, assign a designation to the table from the alpha series "R" to "Z" as required. However, if the special table is similar to, serves the same function, and is used in lieu of one of the standard designated tables, then the alpha designations of the special table are the same as for the standard designated table.

Standard Tabular Formats and Applications

TITLE		DESIG	APPLICATION	
			EQUIPMENT ASSEMBLY	FRAMEWORK ASSEMBLY
Stocklist		None	Required	Required
Features		A	Required	
Mounting plate drilling information		B	Optional	
Wiring provided information	Surface wiring provided by the shop	C	Optional	
	Wiring provided in the local cable	C	Optional	
List of associated drawings		D	Optional	
Supplementary units		E	Optional	
Schematic drawing cross-reference		F	Optional	
Component designation		G	Printed wiring	
Pigtail component location - mounting plates		H	Mounting plate equipment	
Pigtail component identification		Optional	Chassis equipment	
Apparatus or subunit replacement		Optional	Optional	
Engineering guide to the application of lists		Optional	Optional	

5. Feature Table

A feature table is shown on equipment assembly drawings and is always required when the equipment design is ordered by lists or groups. It provides for listing the specific features of the equipment design covered by the drawing, for identifying these features by list or group designations, and for including the associated circuit requirements for each feature. The information in this table is used to select the features needed in ordering the particular makeup of the equipment as may be required for installation in the Telco Central Office.

- The table is prepared in accordance with the following.

The basic format is as shown in Figure 5-C. The table is designated as TABLE A - FEATURES.

Location is shown on Sheet 1, along the top border to the left of the Manufacturing Notes field.

Growth is from the top-down.

	AA	AB	AC	AD	AE	AF	AG	AH
TABLE A - FEATURES								
LINE	EQUIPMENT	RATING	LIST	CIRCUITS AND FIGURES EQUIPMENT SEE NOTE 59				
1	FRAMEWORK, ASSEMBLY, WIRING AND EQUIPMENT FOR ONE STATUS POLLING CENTRAL CONTROL SYSTEM		1	QTY	CKT	FIG.	WRG	APP
			1	1	T-12345-30	1	V	V
				1	T-54321-30	2	X	
2	ASSEMBLY, WIRING AND EQUIPMENT REQUIRED IN ADDITION TO LIST 1 TO PROVIDE DATA FACILITY TEST JACKS		2	1	T-12345-30	2	Z	Z
11	WIRING AND EQUIPMENT FOR LINE UNIT E/W 4W-4W BRIDGE ACCEPTING 1 TO 16 REMOTE STATIONS ALWAYS REQUIRED IN ADDITION TO LIST 1	MFR DISC.	A	1	T-12345-30	3	V.W	V.W
			B	1	T-12345-30	4	V.W	V.W
51	WIRING REQUIRED IN ADDITION TO LIST 1 FOR DATA TELEGRAPH 75 PBS CHANNELS USED WITH 105 PBS		WA	1	T-12345-30	(1)	Y	
				OMIT 1	T-54321-30	2	X	
52				OMIT 1	T-12345-30	(1)	Z	
					T-54321-30	2	X	
	4.6	1.0	5	.7	1.2	.7	1.2	1.2
11.6								

Figure 5-C Format of Feature Table and Entries

- Either list or group designations are used to identify equipment features. In the following paragraphs, references are made only to lists, with the understanding that the same standards apply when group designations are used.
- The various categories of lists, and the order of sequence in which they are initially entered in this table is as follows.

Numbered lists (i.e., 1, 2, 3, etc.), which in general, order the main units of the equipment.

Lettered lists (i.e., A, B, C, etc.), which order equipment not covered by the numbered lists.

Lists prefixed with an ~N" (i.e., NP, NPI, NP2, etc.) which order nameplate replacements for the equipment.

Lettered lists prefixed with an "S" (i.e., SA, SB, SC, etc.), which are optional lists for ordering the stamping for the equipment.

Lettered lists prefixed with a ~T" (i.e., TA, TB, TC, etc.), which are optional lists for ordering testing and adjustment for the equipment.

Lettered lists prefixed with a “T” (i.e., WA, WB, WC, etc.), which are optional lists for ordering wiring without apparatus components for the equipment.

- It is recommended that space be left between each of the categories of lists shown on the drawing to provide for possible subsequent addition of new lists.

Excepting for column width restrictions, there are no limits placed on the space required to describe the equipment feature and enter associated circuit information. Each feature description and associated list and circuit information is separated from the next listed feature by a horizontal line generally shown fully across the table. For examples of the following column entries, refer to Figure 5-C.

- Line Column line numbers are based upon individual list entries and are assigned in sequence according to the category of lists shown as follows.
- If the initial makeup of the table does not provide space between different list categories for the addition of new lists in the same category, line numbering is assigned in numerical sequence starting with the number 1.
- If space is provided for grouping list categories, the initial number of lists in each category and an estimate of new lists that may be added in the same category determines the line number assignments in the initial makeup of the table.
 - The following is an example of a suggested numbering sequence for initial and future lists grouped together in the table.

List Category - Initial Sequence	Line Number Starts With
Numbered Lists (1, 2, etc.)	1
Lettered Lists (A, B, etc.)	11
Nameplate Lists (NPI, NP2, etc.)	21
Stamping Lists SA, SB, etc.)	31
Testing and Adjusting Lists (TA, TB, etc.)	41
Wiring Lists (WA, WB, etc.)	51

With this arrangement, initial Lists 1, 2, and 3 would be assigned line 1, 2, and 3, respectively. Added Lists 4 and 5 would be assigned line 4 and 5, respectively.

When the line numbering is similar to the above arrangement, if the space allocated for adding new lists is depleted or the initial numbering group for a given category has been completely assigned, start with the next number group, i.e., 61, for the line number of the added list. As this condition occurs for each category, the new list is added in random sequence with respect to category, but the line number should be assigned in numerical sequence following the last previous numbered line.

Equipment Column AA entries consist of an adequate, but concise description of the equipment feature, and when necessary, any provisions for selecting the feature in ordering the equipment. For purposes of uniformity, the description phraseology consists of the following.

- Main Lists with Framework: Specify: FRAMEWORK, ASSEMBLY, WRING AND EQUIPMENT FOR followed by description of equipment ordered.
- Main Lists without Framework Specify ASSEMBLY, WIRING AND EQUIPMENT FOR followed by description of equipment ordered.
- Main Lists without Wiring and Framework: Specify: ASSEMBLY AND EQUIPMENT FOR followed by description of equipment ordered.
- Supplementary Lists: For wired equipment, specify: WIRING AND EQUIPMENT REQUIRED IN ADDITION TO LIST-FOR and for nonwired equipment, specify: EQUIPMENT REQUIRED IN ADDITION TO LIST-FOR- followed by description of equipment ordered in each case.
- Stamping Lists: Specify: STAMPING REQUIRED ~ ADDITION TO LIST
- Testing and Adjusting Lists: Specify: TESTING REQUIRED IN ADDITION TO LIST -
- Wiring Lists: Specify: WIRING REQUIRED ~!1 ADDITION TO LIST
- Mandatory Lists: When a list is mandatory, in addition to the standard description of the list, specify: ALWAYS REQUIRED IN ADDITION TO LIST

Rating Column AB entry is the rating of the specific feature, providing the rating of the feature differs from the rating of the drawing as a whole. When shown, the rating is entered using standard 1/8 inch high lettering.

List Column AC entry is the list designation, which when ordered, will provide the equipment described in column AA. Only the number or letter suffix of the list designation is entered. Different lists are not combined as a single entry.

QTY Column AD entry is the quantity of the specific features of a given circuit which are furnished in accordance with the associated list shown in column AC. A list may eliminate a circuit feature furnished by other lists in the Feature Table. In this case, against the list which eliminates the circuit feature, the circuit features in question are entered in columns AE, AF, AG, and AH as required, and the term "OMIT" precedes the quantity entered in column AD.

CKT Column AE entry is either of the following:

- Wiring diagram drawing number of the circuit to be equipped for the equipment furnished in accordance with the associated list shown in column AC.
- If the list in column AC orders in the stock list, a component equipment unit by another drawing, then the drawing number of the component equipment unit is entered in column AE, and not its associated wiring diagram drawing number.

FIG. Column AF entry is either of the following:

- The figures of the wiring diagram shown in column AE, which are furnished in accordance with the associated list shown in column AC. If different figures of the same wiring diagram are furnished in accordance with the list, and the quantity shown in column AD is identical for each figure, then the figures shown in column AF may be combined as a single entry.
- If a drawing number of a component equipment unit is shown in column AE, then the list or group of the component unit is entered in column AF.

WIR Column AG entry is the wiring options furnished per list for the associated wiring diagram or figures shown in columns AE and AF.

APP Column AH entry is the apparatus options furnished per list for the associated wiring diagram or figures shown in columns AE and AF.

In lieu of wiring diagram drawing information, it may be necessary to show schematic drawing information in the Feature Table (see Figure 5-D.)

Information entered is as follows:

- CKT Column AE entry is the same as for the CKT column entry covered in paragraph 5.02 except that in the case of the wiring diagram drawing, enter the schematic drawing number in its place.
- FIG. COLUMN AF entry is the same as for the Figure column entry covered in Section 5 except that figures shown are those associated with the schematic drawing.
- WRG COLUMN AG entry is the wiring options furnished per list for the associated schematic drawing or figures shown in columns AE and AF.

- APP COLUMN AH entry is the apparatus options furnished per list for the associated schematic drawing or figures shown in columns AE and AF.

Figure 5-D Feature Table Schematic Information Entries

Features Ordered by Other Lists: When a feature is referenced to but not furnished by the list, the referenced feature is enclosed by parentheses; refer to examples in List WA and WB in Figure 5-C.

When the parentheses are used, add the following note under Engineering Notes on the drawing, and enter a reference to the associated note number in the column heading following CIRCUITS AND FIGURES EQUIPPED.

~ TABLE A, CIRCUIT FEATURES SHOWN ~ PARENTHESES INDICATED THAT THE FIGURE, WIRING OR APPARATUS IS FURNISHED ELSEWHERE AND NOT AS A PART OF THE (LIST OR GROUP) CONNECTED WITH FEATURE SHOWN IN PARENTHESES.

6. List of Associated Drawings Table

This table is shown only on equipment assembly drawings and is required when the equipment design is directly associated with other drawings. It provides for listing for users' reference purposes, other drawings associated with the equipment design covered on the drawing.

Format, Location, and Growth: Table is prepared in accordance with the following:

- The basic format is as shown in Figure 5-E. The table generally consists of two groups of columns for entries. However, if drawing space is limited, and only a few entries are required, the right-hand group of columns may be omitted.

The table is designated TABLE D - LIST OF ASSOCIATED DRAWINGS.

A supplementary information heading shows DRAWING DESIG - NOT REQUIRED BY THE INSTALLER.

Figure 5-E Format of List of Associated Drawings Table and Entries

- Location is shown on Sheet 1, along the bottom border to the left of the title box.
- Growth is from the bottom-up. On the two-column group format (Figure 5-E), the left-hand group is utilized before making entries in the right-hand group.
- The drawings listed are those specified in the stocklist, associated framework assembly drawings, and shop-assist drawings. Drawings generally excluded from the listing are:

Schematic or wiring diagram drawings.

Drawings listed in a similar table on associated drawings, except when the drawing appears in the stocklist of the drawing being prepared or revised.

- Except for the utilization of consecutive lines, entries do not have to be in any specific sequence.

For examples of the following column entries, refer to Figure 5-E.

- Line Column lines are spaced 1/4 inch apart and line numbers assigned consecutively in the direction of growth starting with the number 1 on the first line. On a two-group column format, the right-hand group line numbering follows in numerical sequence the last line number assigned in the left-hand group.
- Name Column DA entry is the name of the unit, assembly, etc., of the associated drawing to be listed.
- Number Column DB entry is the number of the associated drawing to be listed. The drawing number is prefixed with an equal symbol = if the drawing is not required by the installer.

7. **Wiring Provided Information Table**

This table is shown only on equipment assembly drawings and is always required when the wiring for the equipment design is furnished by the manufacturer or in local cable. It provides for listing information concerning the surface wiring provided for the equipment by the manufacturer and the wiring provided for the equipment in local cable.

Format, Location, and Growth: Depending upon the equipment design, the entries may cover either surface wiring or local cable wiring, or both. Due to these conditions, two basic tables are employed and can be arranged as follows:

- The basic format of the individual surface and local cable wiring tables is shown in Figures 5-F and 5-G.

Depending upon the arrangements of the tables, their designations are as shown in Figure 5-H.

- Location is shown on Sheet 1; see Figure 5-H.
- Growth is from the bottom-up.
- Except for the utilization of consecutive lines in each table, entries do not have to be made in any specific sequence.

Figure 5-F Format of Surface Wiring Provided by the Shop Tables and Entries

Figure 5-G Format of Wiring Provided in the Local Cable Table and Entries

Figure 5-H arrangements of Wiring Provided Information Table

Wiring information entries covered are as follows:

- Local Cable Wiring Entries include only that wiring that is furnished in local cables.
- Surface Wiring Entries include only manufacturer wiring, which may consist of loose wiring or direct wiring or both.

With the exception of an additional feature covered in the local cable entries, the columns and features covered in the surface wiring and local cable tables are identical. For examples of the following common column entries, refer to Figures 5-F and 5-G.

- Line Column lines are spaced 1/4 inch apart and line numbers assigned consecutively in the direction of growth, and as follows:

If either only the surface wiring table or local cable table is shown on the drawing, the first line of the table shown starts with the number 1, see Figure 5-H (a) or (b).

If both surface wiring and local cable tables are shown on the drawing, the first line of the surface wiring table starts with the number 1, and the first line of the local cable table starts with the number 21, see Figure 5-H (c).
- CKT Name Column CA entry is the name of the circuit wired.
- Schematic Column CB entry is the number of the schematic drawing associated with the entry shown in column CA.
- WRG Diagram Column CC entry is the number of the wiring diagram drawing associated with the entry shown in column CA.
- FIG. Column CD entry is the figures wired associated with the entry shown in column CC. In the surface wiring table, the entry is as follows:

AS COVERED IN TABLE A FOR LISTS SPECIFIED IN THE ORDER
- OPT Wiring Column CE entry is the wiring options associated with the entries shown in columns CC or CD. In the surface wiring table, the entry is as follows:

AS COVERED IN TABLE A FOR LISTS SPECIFIED IN THE ORDER
- Wired Column CF entry is the quantity of figures wired associated with the entries shown in column CD. In the surface wiring table, the entry is as follows:

AS COVERED IN TABLE A FOR LISTS SPECIFIED IN THE ORDER
- Note Column CG entry is the note reference designation, when the Remarks column CH cannot be used, and it is necessary to provide additional details

concerning the wiring information entry in a note shown on the drawing. Remarks Column CH entry is any brief remarks required to explain the wiring information entry when necessary.

In addition to the columns covered in the previous paragraph a field is shown to the right of column CH in the local cable wiring table (see Figure 5-G). This field is subdivided into a series of vertical columns, each added as required from left to right, and designed CJ, CK, CL, in sequence, omitting use of CO. Entries are made as follows:

- The initial entry is in the first column on the left, and all subsequent entries are made in the next vacant column on the right.
- In each column, and in the following sequence, enter the number of the local cable drawing, the group by which the cable is ordered on the local cable drawing, followed by the term "PER," and then only the list of the equipment assembly drawing (on which the local cable wiring table is shown) which orders the local cable.
- In the field of boxes formed by the intersecting horizontal lines of the local cable wiring table and the above-mentioned vertical columns, enter the letter "X" in the appropriate box or boxes to indicate in which specific local cable, the wiring specified in the local cable wiring table is provided.

8. Supplementary Units Table

This table is shown only on equipment assembly drawings, and is always required when supplementary equipment units must be furnished with the major units of the equipment design covered by the equipment assembly drawing, but are not ordered as component parts of a list or group in the stocklist on the equipment assembly drawing. It provides for listing supplementary equipment units, the quantities required, and for describing the features or optional conditions for which the unit is required.

Format, Location, and Growth: Table is prepared in accordance with the following:

- The basic format is as shown in Figure 5-J.

The table is designated &S TABLE E - SUPPLEMENTARY UNITS.

A supplementary information heading shows UNITS ARE EQUIPPED AND CONNECTED AS SPECIFIED IN THIS TABLE.

Figure 5-J Format Of Supplementary Units Table and Entries

- Location is shown on Sheet 1, either at the top border of the drawing to the right of the stocklist, or at the bottom border of the drawing to the **left of Table D**.
- Growth is either from the top-down or bottom-up, depending upon its placement on the drawing.
- Either list or group designations are used to identify supplementary equipment units. In the following paragraphs, references are made only to lists, with the understanding that the same standards apply when group designations are used.
- The equipment units listed in this table fall into the following two categories.

Always Required Units should be ordered in addition to the major units of equipment ordered from the equipment assembly drawing on which this table is shown.

Optional Units are only ordered in conjunction with a particular feature or option.

- Except for the utilization of consecutive lines, entries do not have to be in any specific sequence.

For examples of the following column entries, refer to Figure 5-J.

- Line Column lines are spaced 1/4 inch apart and line numbers assigned consecutively starting with the number 1 for the first entry.
- Unit Code Column EA entry is the drawing number of the equipment unit to be listed in this table.
- Unit Code L or GR Column EB entry is the list to be ordered associated with the drawing shown in column EA, and as follows.

Always Required Unit is shown as separate entry and not combined with "optional unit" lists on the same line. Different lists of "always required units" may be combined as a single entry, if the quantity required of the lists is identical.

Optional Unit is shown as separate entry and not combined with "always required unit" lists on the same line.

- Qty Always Req'd Column EC entry is the quantity required of the "always required unit" list shown in column EB. No entry is made for the "optional unit" list shown in column EB.

- Qty for Options Indicated Column ED entry is the quantity required of the "optional unit" list shown in column EB. No entry is made for the "always required unit" list shown in column EB.

- Description of Feature or Option Column EE entry is a brief description of the particular feature or option which indicates when the "optional unit" list shown in column BE is to be ordered. No entry is made for the "always required unit" list shown in column BE.

When entries are initially made in this table, add the following note under engineering notes on the drawing, and enter a reference to the associated note number in the table heading following the title.

THIS FRAME SHOULD BE EQUIPPED WITH UNITS AS REQUIRED IN ACCORDANCE WITH TABLE E.

9. Pigtail Component Location - Mounting Plates Table

This table is shown only on equipment assembly drawings, and only in association with mounting plate-type equipment. It provides for listing pigtail components and their location in respect to surface-mounted components in lieu of showing the pigtail component in the associated mounting plate sketch.

Format, Location, and Growth: The table is prepared in accordance with the following:

- The basic format is as shown in Figure 5-K.

The table is designated as TABLE H - PIGTAIL COMPONENT LOCATION - MOUNTING PLATES.

Figure 5-K Format of Pigtail Component Location - Mounting Plates Table and Entries

- Location is shown on Sheet 1, preferably adjacent to the stocklist if drawing space is available.
- Growth is from the top-down.
- Since the mounting plate sketch designation is the primary source of reference utilized with this table, the initial order to be followed in making entries is in the alphabetical sequence in accordance with the designated sketch reference. Upon determining the order of listing by mounting plate, the subsequent sequence of entries per mounting plate is as follows:

Subgroup pigtail components by type and list subgroups alphabetically, i.e., CAP., followed by DIODE, followed by RES, etc.

Within each subgroup, the listing of components is in the sequence of the assigned alpha or alpha-numeric pigtail component reference designation.

Leave at least two blank lines after each type of pigtail component.

Leave at least two blank lines after each mounting plate grouping of components.

For additions to the table, no attempt is made to rearrange the existing entries. Use blank lines, if available, to add components to existing mounting plates; otherwise, repeat the sketch reference in the table along with only the new components added to the mounting plate.

For examples of the following column entries, refer to Figure 5-K.

- Line Column lines are spaced 1/4 inch apart and line numbers assigned consecutively in the direction of growth, including lines in which no entries are made, starting with the number 1 in the first line. Line numbers are actually only shown in the first line, fifth line, and every fifth line thereafter.
- Desig Column HA entry is the assigned reference designation of the pigtail component as shown in the stocklist.
- Type Column HB entry is the type of pigtail component.
- Desig Column HC entry is the designation of the surface-mounted component with which the pigtail component shown in columns HA and HB is to be associated.
- App Column HD entry is the type of surface-mounted (apparatus) component with which the pigtail component shown in columns HA and HB is to be associated.
- SK Column HE entry is the sketch designation of the specific mounting plate on which the component shown in column HD is mounted. The sketch

designation is identical to the mounting plate sketch designation shown in the stocklist.

- POS Column HF entry is the number of the position on the mounting plate that is equipped with the surface-mounted (apparatus) component shown in column HD.

When this table is initially shown on the drawing, add the following note under Manufacturing Notes on the drawing, and add a reference to the associated note number in the table, in column HA, under the column heading DESIG.

DESIGNATIONS FOR PIGTAIL-MOUNTED APPARATUS AS SHOWN IN TABLE H ARE FOR WIRING INFORMATION ONLY AND SHOULD NOT BE STAMPED.

For each mounting plate equipment group shown in the table, in the stocklist, against the specific mounting plate item, add a reference to Table H.

10. Pigtail Component Identification Table

This table is shown only on equipment assembly drawings, and only in association with chassis-type equipment. The use of this table is recommended only when the equipment contains a substantial number of pigtail components. It provides for listing and identifying pigtail components and eliminates the need for consulting the stocklist for the identity or description of the component.

Format, Location, and Growth: The table is prepared in accordance with the following:

- The basic format of the table is as shown in Figure 5-L. Note that the ZONE column () D is an optional feature of the table, and is only shown when it is desirable to provide a reference in the table to the location of the component in the equipment view in relation to the alpha-numeric reference coordinates shown about the borders of the drawing. If this column is used, and the sheet is redrawn, care must be exercised in realigning the component locations in the table with the possibly new position of the equipment view in respect to reference coordinates. The table is designated as TABLE () - PIGTAIL COMPONENT IDENTIFICATION. An alpha designation is shown in place of the parentheses, and any designation in the series R to Z that has not been previously assigned to another table on the drawing may be used. The same designation is carried over into the column designations:

Figure 5-L Format of Pigtail Component Identification Table and Entries

- Location is shown on the particular sheet of the drawing containing the view of the chassis equipment that the table is associated with. If the drawing contains more than one view of the chassis equipment and the ZONE column is used, separate tables are required for each view. If the ZONE column is omitted, the following apply.

If the views are contained on the same sheet, and the pigtail components and their arrangements are identical in all views, show only one table and a reference to the table in each view designation.

If the views are contained on the same sheet, and the pigtail components or their arrangements differ in each view, show only one table, but group the entries in the table according to each view. Show brackets outside the table with each group of components and a reference to the associated view. In each equipment view, add a reference to the table in the view designation.

If the views are shown on different sheets of the drawing, show separate tables adjacent to each view.

- Growth is from the top-down.
- The order of listing components is in sequence by type of component and component reference designation as follows:

Subgroup pigtail components by type, and list subgroups alphabetically, i.e, CAP., followed by DIODE, followed by RES, etc.

Within each subgroup, the listing of components is in the sequence of the assigned alpha or alpha-numeric pigtail component reference designation.

Leave at least two blank lines after each type of pigtail component.

Leave at least two blank lines after each subgroup.

For additions to the table, no attempt is made to rearrange the existing entries. Use blank lines, if available, to add components to present subgroups; otherwise, repeat the component type in the table and enter the new components to be added.

For examples of the following column entries, refer to Figure 5-L. On the drawing, show the assigned table alpha designation in place of the parentheses in the following column designations.

- Line Column lines are spaced 1/4 inch apart and line numbers assigned consecutively in the direction of growth, including lines in which no entries are made, starting with the number 1 in the first line. Line numbers are actually only shown in the first line, fifth line, and every fifth line thereafter.

Desig Column () A entry is the assigned reference designation of the pigtail component as shown in the associated view of the chassis equipment.

Type and Code Column () B entry is the type and code number of the component associated with the entry shown in column () A.

Value Column () C entry is the electrical value of the component shown in column () B.

Zone Column () D is optional; for application refer to paragraph 10.02 of this Section. When used, the entry made is the location of the column () C component in the equipment view. This entry is alpha-numeric, and is the zone coordinates of the component shown in the equipment view in respect to the reference coordinates shown about the drawing borders.

When this table is initially shown on the drawing, add the following note under Manufacturing Notes on the drawing, and add a reference to the associated note number in the table following the title.

DESIGNATIONS FOR PIGTAIL-MOUNTED APPARATUS AS SHOWN IN TABLE () ARE FOR WIRING INFORMATION ONLY AND SHOULD NOT BE STAMPED.

11. Apparatus or Subunit Replacement Table

This table is shown only on equipment assembly drawings, and only in association with stocklist changes incorporating replaced items. It provides for listing and identifying replaced apparatus items or printed wiring assembly items and replacements, and for associating the items with the particular item in the stocklist.

Format, Location, and Growth The table is prepared in accordance with the following.

- The basic format is as shown in Figure 5-M.

Table is designated as TABLE () - APPARATUS OR SUBUNIT REPLACEMENT. An alpha designation is shown in place of the parentheses, and any designation R to Z that has not been previously assigned to another table on the drawing may be used. The same designation is carried over into the column designations.

A supplementary information heading shows SL LINE REF DESIGNATED DENOTES FURTHER REPLACEMENT. FOR NEW REPLACEMENT REFER TO IDENTICAL SL LINE REF NO. SHOWN WITH A LETTERED SUFFIX ~ THIS TABLE.

- Location is shown on Sheet 1, if space is available. If shown on another sheet, attempt to confine its location to an existing sheet containing tables.
- Preferred growth is from the top-down, although this may also depend upon its location.
- The format shown in Figure 5-M is used on drawings with the standard stocklist format.

Figure 5-M Format of Apparatus or Subunit Replacement Table and Entries - Stocklist Format

- Table entries should be correlated with specific asterisk * designated items in the stocklist. The primary source of cross-reference is the line number in the SL LINE REF column, which when assigned, is identical to the line number of the associated stocklist item. Initial entries are in numerical sequence in accordance with the assigned line numbers. Additions will depend upon item replacement activity in the stocklist, and subsequent entries may not necessarily be in any numerical sequence.

For examples of the following column entries, refer to Figure 5-M. Show the assigned table alpha designation in place of the parentheses in the following column designations.

- SL Line Ref Column lines are spaced 1/4 inch or more apart and the line number entry is identical to the line number assigned to the associated asterisk-designated stocklist item.
- Column () A entry is as follows:

Figure 5-M Ident No. apparatus number or drawing number and lists or groups previously shown, and now erased and replaced by an * symbol in the IDENT NO. column of the stocklist.

- Column () B entry is as follows: -
Figure 5-M App Code apparatus code number previously shown and now erased from the DESCRIPTION column of the stocklist and also identified by an * symbol in the associated IDENT NO. column in the stocklist.
- Column () C entry is as follows:
Figure 5-M Ident No.: Apparatus number of the replacing component to be shown in column () D.
- Column () D entry is as follows:
Figure 5-M APP CODE: Apparatus code number of the replacing component associated with the apparatus shown in column () B.

Once the stocklist item is initially replaced, its replacement in turn also may be subsequently replaced, and these items are treated as follows. After the initial replacement of the stocklist item has been covered in the table, and the replacing item, contained therein is itself subsequently replaced, apply the following procedures.

- Against the initial appearance of the affected item in the table, add a solid triangular symbol in the associated SL LINE REF column (see Figure 5-M and 5-N).
- For the second generation replacement, show a new entry using the same SL LINE REF number, but suffixed with the letter A, and complete the entries in columns () A to () D (see Figure 5-N).

Figure 5-N Second Generation Replacement

When the table is initially shown on the drawing, add the following note under Manufacturing Notes on the drawing, and add a reference to the associated note number in the table following the title. In the note, refer to the sheet number if the table appears on other than Sheet 1.

IDENTIFIES ITEMS IN THE STOCKLIST THAT ARE ELECTRICALLY AND MECHANICALLY INTERCHANGEABLE AND CAN BE FURNISHED AT THE DISCRETION OF MANUFACTURING. FOR A LISTING OF THESE ITEMS, REFER TO THE LINE NUMBER IN TABLE () (ON SHEET) THAT

CORRESPONDS WITH THE LINE NUMBER OF THE AFFECTED ITEM IN THE STOCKLIST.

12. Schematic Drawing Cross-Reference Table

This table is shown only on equipment assembly drawings, and only when no wiring diagram drawing exists for the equipment design, and the circuit figures and options are shown on the equipment assembly drawing. It provides for listing the schematic drawing figures and options, and the associated wiring figures and options shown on the equipment assembly drawing.

Format, Location, and Growth: The table is prepared in accordance with the following:

- The basic format is as shown in Figure 5-P.

Table is designated a TABLE F - SCHEMATIC DRAWING CROSS-REFERENCE.

A supplementary information heading shows INFORMATION IN [] IS FOR REFERENCE ONLY AND IS NOT TO BE RECORDED ON THE JOB WIRING LIST.

Figure 5-P Format of Schematic Drawing Cross-Reference Table and Entries

- Location is shown on Sheet 1. Its position on the sheet is optional.
- Growth is either from the top down or bottom-up, depending upon its placement on the drawing.
- Except for the utilization of consecutive lines, entries do not have to be in any specific sequence.

For examples of the following column entries, refer to Figure 5-P.

- When entries are initially made, enter the SD- drawing number reference in the column heading field associated with columns FA and FB, and the equipment assembly drawing number containing wiring figures and options in the column heading associated with columns FC, FD, and FE.

Line Column lines are spaced 1/4 inch apart and line numbers assigned consecutively starting with the number 1 for the first entry.

FIG. Column FA entry is the figure number of the schematic drawing for the equipment design covered.

OPT Column FB entry is the circuit wiring or apparatus options associated with the schematic drawing figure shown in column FA.

FIG. Column FC entry is the wiring figure number shown on the equipment assembly drawing and associated with the schematic drawing figure shown in column FA.

WRG Column FD entry is the wiring option furnished associated with the figure shown in column FC.

APP Column FE entry is the apparatus option furnished associated with the figure shown in column FC.

Remarks Column FF entry is any brief remarks required to explain the wiring information entry.

13. Engineering Guide to Application of List Table

This table is shown only on equipment assembly drawings, and only when the drawing contains an excessive number of lists (or groups) covering numerous features furnished under such varying conditions that the use of TABLE A FEATURES alone is difficult in selecting the proper lists or groups. It provides for the users' reference, a grouping of lists (or groups) required by some particular application such as: feature, system, office condition, etc., and accompanied by any necessary remarks as may be required for interpretation of the particular application.

Format, Location, and Growth: The table is prepared in accordance with the following.

- The basic format is as shown in Figure 5-Q. Observe that due to variations in informational content that may be shown in certain columns, these column widths may be determined when the table is shown on the drawing. The table is designated TABLE () - ENGINEERING GUIDE TO APPLICATION OF LISTS. An alpha designation is shown in place of the parentheses, and any designation in the series R to Z that has not been previously assigned to another table on the drawing may be used. The same designation is carried over into the column designations.

Figure 5-Q Format of Engineering Guide to Application of Lists Table

- Location is shown on Sheet 1, preferably in the vicinity of Table A.
- Growth is from the top-down.
- Either list or group designations are entered in this table. In the following paragraphs, references are made only to lists, with the understanding that the same standards apply when group designations are used.
- Except for the utilization of consecutive lines, entries do not have to be in specific sequence.

No limit is placed on the space required to describe the application and to enter the group of lists and associated remarks. Each application and associated entries is separated from the next listed application by a horizontal line shown fully across the table. On the drawing, show the assigned table alpha designation in place of the parentheses in the following column designations.

- Line Column line numbers are assigned consecutively starting with the number 1 to each application entry.
- Application Column () A entry consists of a description of the features, system, office conditions, etc., which determine the selection of a particular group of lists specified in TABLE A - FEATURES.
- QTY Column () B entry consists of the quantities required of each list to be shown in column () C.
- List Column () C entry is the grouping of lists required, and only the number or letter suffix of the list designations is entered.
- Remarks Column () D entry is any information required to expand or interpret the application described in column () A.

1. General

This Section describes the documentation that the Telco in support support of a product. This documentation is used for engineering, installation, maintenance, inventory control, and establishment of property record required by the Federal Communications Commission (FCC) and local utility laws.

The documentation or its equivalent referred to above consist of:

- Circuit schematic drawing
- Circuit description
- Wiring diagram drawing

In addition, within the above product documentation there should be included a means by which the product's vintage, model, serial number, etc. can be retrieved by the customer and communicated to the manufacturer if product improvements are desired, when replacement parts are needed, or to clear problems that may occur during the product's lifetime.

Those who provide the concepts for the product and those who record them for the product manufacturer are referred to as the product and/or circuit designer.

1. General

Circuit Schematic Drawings consist primarily of appropriate graphical symbols or conventions representing the apparatus components such as relays, inductors, capacitors, and resistors interconnected by a circuit pattern.

The manufacturer assigns a Schematic Drawing number to the product's circuit. This number is consistent with the numbering conventions of the manufacturer.

The Circuit Schematic Drawings may employ a numbering scheme starting with the prefix SD and all future references in this publication will use SD interchangeably with the concept of schematic drawings.

The structure of the schematic numbering scheme typically consists of three parts: the prefix SD, a 5-digit base number, and a suffix, i.e., SD-2A000-01.

The suffix numbers used on Circuit Schematic Drawings are -01 to -09. Each number in this series indicates a separate and distinct drawing and is assigned serially to each drawing required to complete the schematic series for a single circuit. In order to avoid showing more than one extensive optional arrangement on a single drawing, separate drawings are made which are identical except for the optional arrangement. Each of these drawings has the same base number but a different suffix such as -01, -02, etc. Only one drawing is used to show the optional circuit arrangements if wiring changes are not extensive. Where more than one sheet is required, they should be numbered -01, -02, etc., followed by additional numerals or a combination of a letter and numerals.

Detached-contact-type drawings are described in detail in Bell Communications Research PUB 53329, Detached-Contact Type Schematic Drawings.

Apparatus conventions and connections on the SD drawings show only electrical interconnections and operational characteristics in order to facilitate tracing the circuit operation. Functional designations are usually assigned to apparatus to aid in identifying different items. A summary of wiring and cabling conventions used in schematic drawings is contained in Bell Communications Research PUB 53328, Symbols for Circuit Schematic Drawings.

The several types of notes included on SD drawings are as follows:

- Circuit notes pertain to the operation of the circuit such as fusing, features or options, network and job record information, including circuit drains on battery supplies or commercial ac power and specify whether connection of the product to emergency power is required should the commercial power fail. These notes also contain circuit grounding information and the circuit's operational limits.
- Equipment notes cover circuit engineering information such as restrictions of apparatus, size of wires, length and resistance of leads, etc.

- Information notes give information of a general nature which cannot be included in other more specific types of notes and include such information as interrupter intervals or timing, position of switches, normal post spring operation, etc.
- Cross-connection notes are explanatory notes covering information in the cross-connection information table.
- Test notes are associated with circuit timing, transmission test and electrolytic capacitor test requirement tables.
- Sheet notes clarify information on that particular sheet of the drawing.

2. Requirements Tables

Circuit and Timing Requirements Tables

- Each SD drawing which shows adjustable apparatus includes one or more tables of circuit requirements. The requirements may either be in a table marked "Circuit Requirements" or in a table marked "Timing Requirements." A detailed description of circuit requirement tables is contained in Bell Communications Research PUB 53329, Detached-Contact Type Schematic Drawings.

Tables marked "Circuit Requirements" cover electrical and mechanical requirements applicable to apparatus such as relays, drops, signals, and rotary selectors. Certain other types of apparatus such as sequence switches, clutches, trip magnets, bells, buzzers, position clocks, keys, and ringers are listed only where special requirements are involved. In some cases, tables marked "Circuit Requirements" may contain timing requirements.

Tables marked "Timing Requirements" are used to cover the timing requirements applied by the timing test set and requirements expressed in pulse per second and in percent break of the pulse cycle. Timing requirements are in some cases necessary for relays and timed relay interrupter circuits. These requirements supplement the direct current flow requirement shown in the circuit requirement table.

Circuit requirement tables should include information necessary for isolating apparatus and this information should be included on reissues of older circuit requirement tables whenever practical.

Transmission Test Requirements Tables

- Transmission test requirement tables, as described in Bell Communications Research PUB 53337, Transmission Test Requirement Tables, are shown on SD drawings covering circuits through which talking or transmission paths are established.
- Two general types of transmission test requirement tables are shown on SD drawings. One type covers 1000-cycle loss requirements, and the other type covers

gain requirements at single frequencies and gain and loss requirements at multifrequencies.

Cabling Requirements Tables

- The schematic drawing shows the circuit designer's intent and recommendations on how the product's external wiring should be connected to power supplies, signal sources, transmission paths, etc., to allow the product to function individually or as part of a system according to the product's advertised specifications.
- Cabling, terminal assignment, lead multipling and some cross-connecting information is included on circuit schematic drawings in separate figures to show the method of wiring between units of equipment and pieces of apparatus.
- Where cross-connections are subject to periodic changes, the application, location, and assignment of terminals and the type and color of wire used are included on SD drawings.
- Where shield cable or specially designed cable assemblies or cable codes are needed to interconnect the product, the schematic's cabling figure indicates such requirements and identifies which cable manufacturer or supplier can furnish such interconnection facilities.

1. General

Circuit Descriptions (CD sheets) are prepared in connection with SD drawings. They contain text material and supporting illustrations, when required, to describe the purposes, functions, method of operation, etc., which may not be readily apparent from an inspection of the circuit schematic drawings. Circuit Description sheets are issued on letter-size pages and carry the prefix CD, the same base number, and the first two digits of the suffix of the corresponding SD drawing.

Circuit Descriptions generally provide the following information:

- General use and/or purpose of circuit and general method of operation.
- Detailed description of the method of operation.
- Electrical working limits such as conductor loops, insulation resistance, earth potentials, voltages, etc.
- A list of circuit functions.
- A list of connecting circuits.
- Reasons for reissue.

In order to keep the complete explanation of design up to date with circuit changes, circuit descriptions will include, where applicable, the following information:

- Explanatory cross-connection information for larger complicated circuits where the major portion of this information is on the SD drawing.
- information for removing all or a part of the circuit from service.
- Information necessary to respond intelligently to alarms and signals and to assist in the interpretation of alarm signals and trouble conditions.
- Photographs, dimensions, and simplified sketches of a test set covered by a single SD drawing.
- Explanation of the functional designations of the operating elements used in the circuit.
- Manufacturing test requirements.

Circuit description revisions should include the information in the above paragraph whenever practicable, and it is intended that such information will supersede any previous corresponding information for the particular circuit involved.

Changes in circuit descriptions resulting from corresponding changes in the circuit schematic drawing are covered either by appendices to, or where the changes are extensive, by a reissue of the circuit description. In the case of a reissue, all applicable information in outstanding appendixes is incorporated in the new issue.

1. General

This Part covers general information, the point-to-point method, and simplified airline method of preparing and maintaining wiring diagrams (WDs). WDs are made up to show the actual method and type of wiring installation with respect to the physical arrangement of equipment as viewed from the wiring side, methods of running and terminating wire, type and color of wire used, etc. Besides containing information which will be useful for manufacturing purposes, a WD may also be used in connection with installation and maintenance. For further use in this document, the abbreviation WD will be used in place of wiring diagram.

Reference information for tabular wiring diagrams is contained in Bell Communications Research PUB 53325, Tabular Wiring Diagrams-Description.

There are two primary methods of presenting information on WDs which are the point-to-point (full line) and simplified airline. These two methods permit a selection which will satisfy the requirements of a wide range of equipment designs. The point-to-point method has the widest application on apparatus drawings, and the simplified airline method is used almost exclusively in the preparation of systems and apparatus data set WDs.

While there are differences in the methods of preparation between the point-to-point and simplified airline methods, there are certain requirements which are common to all of them and these are covered in the following paragraphs.

The only view or views which are shown on a WD are those which are sufficient to show all of the terminals of the assembled components from the wiring side. How many views are needed in the presentation of a particular WD will depend upon wiring path complexities. When more than one view is required, adjoining view relationships are clearly indicated (the paragraph below shows the method of indicating this relationship).

The plane of the drawing sheet always corresponds to the view of the wired assembly in which the greatest portion of the components are mounted (see Figure 6-D-A). When components mount on planes perpendicular or at an angle to this principal plane, these other planes and the components mounted thereon are shown rotated into the plane of the drawing sheet. The particular direction of rotation is selected which will most clearly show the components from a normal wiring side position. In general, it is not necessary to completely delineate the four sides of a plane with phantom lines. It is necessary to indicate merely the line about which rotation between planes occurs. As this line usually coincides with an actual feature of the mounting structure, it is recommended that a descriptive designation be assigned to the line for purposes of identification or orientation (see HINGE LINE in Figure 6-D-E).

In representing components on WDs, all shapes are reduced to the simple geometric form of either the circle or rectangle. The circle is used when the component, as viewed from the wiring side, is of circular shape. However, all other component shapes which are even remotely rectangular are represented as rectangles of

appropriate size. These symbols are usually 1.25 inches high and as long as required except for pigtail components. Pigtail-mounted components may be shown as rectangles of varying sizes according to need and available space.

Figure 6-D-A Method of Rotating Wiring Views Into Plane of Drawing Sheet

No deliberate attempt should be made to differentiate size variations among components especially when the components are basically similar in shape or in function. For example, a rectangle of a particularly suitable size may be used to represent all of the pigtail-mounted apparatus shown on a WD when physical size variations of the components are minor. In general, components are drawn as small as possible while remaining consistent with the maintenance of a clear, well proportioned representation. If, in order to differentiate between the extremes of component sizes, maximum and minimum size representations are selected, the largest is not made to appear too large nor the smallest to small.

Resistor, capacitor, and inductor values are indicated on the WD.

In planning the layout of a WD, the relative spacing of component symbols approximates the physical spacing shown on the assembly drawing. Within reasonable limits, the spacing may be made proportionately greater or smaller in order to avoid unnecessary crowding of connection lines and designations, or to the extent that this space variation will serve to simplify the layout.

2. Component Terminals

In general, terminals of components are represented as small circles with diameters ranging from a minimum of 0.06 inch to a maximum of 0.12 inch. The maximum size terminal circuit is reserved for terminal punching and strips, binding posts, and standoff terminals. Terminals are shown as circles even when physical appearance differs markedly from the circular form.

Terminal numbers indicated on WDs should agree with those shown on circuit schematic drawings or with those marked on the component if not indicated on the circuit schematic drawing.

To facilitate showing terminals that are in a plane perpendicular to the item-mounting surface, the sides of the item containing the terminals may be revolved into the plane of the drawing (see Figure 6-D-B).

Figure 6-D-B Typical Symbol Representation When Several Rows of Terminals are on Opposite Sides of the Component

If the terminals of a variable resistor are numbered on the circuit drawing, indication of this marking on the WD symbol takes into consideration the direction of movement of the adjustable contact. For example, if the terminal marking is given as 1, 3, 2, the movement of an adjustable contact from the position of a lower to higher numbered terminal will indicate counterclockwise rotation when the variable resistor is viewed from the rear or wiring side (see Figure 6-D-C).

Note: If terminal markings are not indicated on the circuit drawing, terminal identifications may be assigned in a manner similar to that shown in Figure 6-D-C but should agree with the numbering marked on the component.

Figure 6-D-C Typical Terminal Indication on a Variable Resistor when Viewed from the Wiring Side

In order to facilitate showing several rows of terminals on one or both sides of a component, the symbol is shown as though the terminal sides were rotated into the plane of the drawing sheet (see Figure 6-D-B).

When a component or an assembled group of components is mounted on end, the designation B1 is used to indicate the terminal or groups of terminals nearest the mounting surface (see Figure 6-D-E).

3. Wires

When terminals of the same, adjacent, or closely associated components are to be connected, the connection is often made with a wire strap. In regard to showing wire straps on the same component, the connecting line is drawn directly whenever this form of representation is warranted. When the connecting line cannot be run directly because of interference with other terminals, the connecting line is offset inside or outside of the components. For connections between terminals of adjacent or closely associated components, the connecting line is usually run outside the component outline.

When it is necessary to indicate shielding for a wire or a group of wires, the symbols to be used are in accordance with Bell Communications Research PUB 53351, Wiring

Symbols, Wiring Abbreviations, and Definitions-Wiring and Cabling. The shield symbol is shown at each termination of a connecting line or connection and as close to the terminal end as possible.

4. Spliced Connections

The symbol shown in accordance with the manufacturer's conventions or Bell Communications Research PUB 53351 is used to indicate spliced connections on WDs.

Openings, circular or otherwise, in mounting surfaces through which wires pass if not shown on assembly drawings, are indicated with a phantom line and identified "WIRE HOLE" (see Figure 6-D-D). Holes are designated HOLE A, HOLE B, etc., when there is more than one hole to identify. The connecting lines representing the wires passing through the hole may be drawn to the edge of the hole or run through it, depending on which method is more convenient (see Figure 6-D-D) for example of each method). Where it is necessary to identify wires at edge of hole, wire designations or numerals may be used for this purpose.

Figure 6-D-D Method of Showing Passage of Connecting Lines Through Holes

In order to differentiate between wires of the same color which would break out from the same point in the cable if not separated, the designations F, F1, F2, etc., are used. This is done regardless of wire differences as to gauge or type. The need for F stitching is indicated in accordance with the wiring practices described in PUB 53351, Wiring Symbols, Wiring Abbreviations, and Definitions-Wiring and cabling.

Simplified figures to correspond to the figures shown on the schematic drawing together with appropriate subtitles are shown on the WD for all coded component assemblies, such as, test sets, cords, handsets, desk stands, transmitters, and similar equipment. When adjacent components are connected directly to each other by butting or overlapping, the terminals are designated LL.

Show notes as required to explain all wiring symbols, such as, coaxial shield connection, wires run in switchboard cable, cross-connecting terminal, etc.

Use a dotted line convention to indicate connections (rewiring) which are furnished as a part of the component and explain by means of a manufacturing note reading as follows:

CONNECTION FURNISHED AS PART OF COMPONENT

5. Point-To-Point Method

WDs prepared by the point-to-point method are the type illustrated in Figure 6-D-E. In this method, continuous lines are drawn to indicate the actual terminal-to-terminal connections of the assembled unit. The paths of the connecting lines, as drawn, are not intended to indicate the actual arrangement of wires on the unit. However, sequence of connection should be selected on the basis of the shortest path from terminal to terminal consistent with the overall cable path direction shown on the assembly drawing. When it is necessary to indicate specific wiring paths, the delineation of the connections and the relative location of the components is drawn to scale.

Use this method only for relatively simple units (such as apparatus) where crossing of lead lines will not make the diagram difficult to read. In no case should this type of diagram consist of more than one sheet.

6. Simplified Airline Method

The distinguishing feature of the simplified airline method of drawing is that it eliminates the need for drawing continuous connecting Lines from terminal to terminal as required in the point-to-point method. Connections, except those which are run directly, are indicated with short lines of uniform length. These lines are drawn from the components into conveniently located base Lines. Circuit continuity is established by means of component location numbers (terminating numbers) which appear close to the base line (see Figure 6-D-F and 6-D-G). Because of the elimination of connecting lines, the simplified airline method lends itself to the representation of wiring information when the connections are numerous and the wire paths involved. Unless otherwise indicated in the following paragraphs, the general practices established in the previous paragraphs also apply to the simplified airline method.

7. Component Location Numbers

For ease of locating components or groups of components on the drawing, location numbers should be assigned in ascending order from left to right and top down. Location numbers are not assigned to pigtail components which mount by the furnished leads, and for this reason there is no base Line termination for these pigtail leads. For example, see R2 of Figures 6-D-F and 6-D-G.

Location-apparatus WDs component location numbers are located to the left and slightly above the component representation (see Figure 6-D-F).

Location-equipment product WDs location number is generally located in the upper left-hand corner of the component representation (see Figure 6-D-G). When space is lacking, the location number may be placed outside the representation.

Unused location numbers may be reserved for future component additions, otherwise, the order of assignment is consecutive. In the event of additions between two existing, consecutively numbered components, the added components are assigned the number

of the lower-numbered existing component followed by ~ 2, -3, etc., depending on the number of components added (see Figures 6-D-F and 6-D-G).

Figure 6-D-E Point To Point Method - Apparatus Application

On apparatus WDs, component reference designations are placed outside the component symbol where the reference designation is stamped on the mounting surface (see Figure 6-D-F). When not stamped on the mounting surface, component reference designations are placed inside the component symbol (see Figure 6-D-F)~ R2 resistor.

On equipment product WDs~ component reference designations are enclosed in parentheses (see Figure 6-D-G)~

8. Component Identity - Product Drawings

On equipment product drawings, component identity includes, besides reference or functional designations, the apparatus code number and such other information as may be required to establish complete identity of the component (see Figure 6-D-G)o

Figure 6-D-F Simplified Airline Method as Applied to Apparatus Wiring Diagram

Figure 6-D-G Simplified Airline Method as Applied to Equipment Product Wiring Diagram

9. Base Line

The base line at which feed lines terminate is conveniently located to all components. Use separate base lines for each figure. All base lines within a figure are joined either by other horizontal or vertical base lines or feed lines to components. Base Lines of one figure on the WD are not joined with base lines of another figure on the same WD.

10. Feed Lines

Feed lines symbolize wires which originate or terminate at a terminal. A single feed line may represent more than one connection to a terminal. However, when there is more than one cable assembly or when gauge and type of wire are different, it is preferred that separate feed lines be used. Additional feed lines can be shown as required in case the colors, terminations, and other running or connecting information would cause congestion. Individual feed Lines are shown for each lead in all cases of PAIRED leads to be run as miscellaneous wiring by the installer. Feed lines are as long as required but no shorter than 1.50 inches. The lines are drawn perpendicular to the base line. Two feed Lines which terminate at the base line from opposite sides do not intersect the base line at the same point but are staggered to avoid giving the impression of continuity across the base line. The base line extends a short distance beyond the end feed lines as shown in Figures 6-D-F and 6-D-G.

E a line represents two or more leads of different colors, the color shown nearest to the component terminal is associated with the location number nearest the terminal, and other colors and location numbers are arranged in the same relative order.

Terminating feed line numbers shown near the base line indicate the component or components to which the feed line is directed.

11. Identification - Wires and Cables

If wire identification is required in addition to that provided by terminating numbers, a suffix letter is added to the feed line terminating number. This additional identification is generally required for surface-wired equipment, when two or more terminals of one component are to be connected to terminals of another component with wire of the same color.

When it is necessary to differentiate between wires of the principal cable and those of secondary cables, the designations CA2, CA3, CA4, etc. serve to identify the secondary cables. In the sense used here, the term principal cable refers to the cable containing the greatest number of wires. Unless it is otherwise specified, all wires are contained in the principal cable. A note to this effect is used on the drawing, for example: ALL WIRES ARE INCLUDED IN THE CABLE ASSEMBLY XXXXXXXX UNLESS OTHERWISE SPECIFIED.

Wire colors are indicated on each feed line, except when the wires are generally of the same color. Wire colors are shown on feed lines approximately midway between the base line and terminal and are abbreviated in accordance with PUB 53351, Wiring Symbols, Wiring Abbreviations, and Definitions-Wiring and Cabling.

When wires are generally of the same color, the wire color indications may be omitted from the feed lines and covered by means of a note instead.

A feed line representing more than one wire of different colors has the colors indicated in the same order in which the terminating numbers appear on the feed lines.

12. Pigtail (PT) Leads

The term "pigtail lead" is used in referring to leads which are furnished with the component and permanently connected to it. Whenever possible, pigtail leads are run directly, terminal to terminal and not into the base line. The designation PT is required to identify pigtail leads only when the component is furnished with insulated leads which in no way serve to hold the stud- or screw-mounted component in place. Pigtail leads of pigtail-mounted components need not be designated PT on the WD, but may be covered in a manufacturing note instead. A suggested note for this purpose is as follows: LEADS SHOWN TERMINATED COMPONENTS WITHOUT TERMINALS ARE FURNISHED WITH COMPONENTS.

When pigtail leads are run into the base line, the identification PT is used, and the PT identification is explained by means of a manufacturing note reading as follows: PT

LEADS FURNISHED WITH COMPONENT. Colors of colored pigtail leads are indicated on the feed line.

When pigtail leads required special treatment, the identification P_{Ta}, P_{Tsl}, etc., is used.

With pigtail components conventions show a simple rectangular convention as illustrated in Figure 6-D-F, R₂ resistor (apparatus WDs) and Figure 6-D-G, (R") resistor (Systems WDs).

Note: When the illustration of pigtail components in the conventional manner will overly congest a drawing or be confusing, an alternate method, critical wiring, may be used. In this method only the designation of the component is shown on the WD and the details of the component, that is, designation, type, value, and location are shown in tabular form.

13. Designations

Show designations indicating the kind of wiring, such as, A, C, C1, P, T, Q, D, SW1, etc., on both ends of a lead except when pairs, triples, or quads are split.

Add arbitrary letters to the location numbers to distinguish between two or more leads of the same color and type (local cable, D, D1, etc.), run between the same component locations, for example: 35A to 35A, 35B to 35B, etc. When assigning lead designations on leads to letter punchings of a terminal strip or from a component location to a bracket location, use the terminal strip or bracket location number, and the letter designation of the terminal punching or lead designation on the end of the lead. Designations, such as T, R, S, L, AC, DC, G, etc., are not used as arbitrary lead designations except in an alphabetical sequence because they are likely to be confused with functional designations. Arbitrary G would not be confused with functional G if it appeared between arbitrary F & H. So far as -practical, however, the letter designations on the ends of the leads at the bracket should agree with the corresponding designation on the associated schematic.

Cords are coded cable units which are identified with an enclosing cable symbol (Figure 6-D-F).

1. General

Apparatus WDs cover items, such as, filters, test sets, etc. Unless otherwise indicated in the following paragraphs, the basic practices of this Part, Wiring Diagram-General and Tabular, apply to the preparation of apparatus WDs. In apparatus applications, WDs may appear on individual sheets as principal drawings or in combination with assembly and/or circuit information on a single sheet drawing. Figure 6-D-E is an example of a typical apparatus WD prepared on an individual sheet basis. Regardless of the presentation used, a separate apparatus WD is prepared to cover each circuit variation, exclusive of those involving only component value differences. Drawing numbers are assigned by the manufacturer in accordance with appropriate numbering schemes.

Titles for apparatus WDs consist of the code identification and the name of the component (apparatus), for example: 245 FILTER WIRING DIAGRAM and 103A TEST SET WIRING DIAGRAM.

2. Component Reference Designations

On apparatus WDs, reference designations are placed outside the component symbol when the reference designation is stamped on the mounting surface (Figure 6-D-E). When not stamped on the mounting surface, reference designations are placed inside the component symbol. For example:

3. Wires

On apparatus WDs, wire colors are specified only when the use of a specified code is an engineering requirement. When it is necessary to show wire colors on the WD, the code is shown as indicated in Figure 6-D-E. The wire color selected is in accordance with the manufacturer's conventions.

When the connecting line from one component terminal to another is short, the color designations R, R-W, R-BL-W, BK-W, etc., are shown approximately in the middle of the connecting line. However, when the connecting line is longer than 6 inches, the color designation is placed at both ends of the connecting line and as near as possible to each terminal.

Wires not included in the cable assembly are called for (when necessary) by type, gauge, and color in the stock list of the main assembly. Item numbers serve to establish identification on the WD. These item numbers are shown on the wire line immediately following the color abbreviation. If no color is indicated for the wire, as in the case of wire straps, the item number is located approximately midway between terminals. When space is limited, this may be done by leader line (see component T1 in Figure 6-D-E).

Wire sleeving is indicated by item number. When the sleeve is used to cover a bare wire strap, the item number of the sleeve preceded by a comma follows the item number of the strap wire as shown in Figure 6-D-E for items 66 and 68 of component S3.

When used in conjunction with cable assemblies, D method wiring applies to wires which follow specific paths other than those of the cable assemblies. To differentiate these wires from those not included in the cable assembly and to specify the particular path requirements, the designations D, D1, D2 or D3, are used. The applicable designation is placed on the connecting line following the color designation.

4. Drawing Notes

Drawing notes are placed in the upper right-hand area of the drawing sheet whenever possible (see Figure 6-D-E). In general, the notes refer to (a) wires which are or are not included in the cable assembly, (b) item numbers as the means for identifying wiring items in the stocklist of the main assembly, (c) soldering procedures, if any, which need to be specified, and (d) such wiring abbreviations or symbols which need to be identified or explained. Typical of some of the items which require defining in this fourth category of WD notes are Bl, D, D1, D2, D3, F, P, Pr, TW, etc. For definitions, see Bell Communications Research PUB 53351, Wiring Symbols, Wiring Abbreviations, and Definitions-Wiring and Cabling.

1. General

Equipment product wiring diagrams cover equipment, such as, the mounting plate type, in which electromechanical components (relays, switches, etc.) predominate, and the chassis or tray type, in which semiconductor devices are predominant. Unless otherwise indicated in the following paragraphs, the basic practices for wiring diagram general information apply to the preparation of equipment product WDs.

Equipment product WDs are drawings which specify wiring for the assembly of equipment or equipment units. Because of the number of components for which wiring information must be provided for the average equipment unit, equipment product WDs are often comprised of more than one sheet. When the WD is prepared from a schematic drawing, the WD will have the same base number as the schematic. In conformity with this numbering plan, a WD should not ordinarily include wiring from more than one schematic. In case it is desirable for manufacturing reasons to include wiring from more than one schematic on a WD, consideration should be given to requesting a change in the schematic. If a change in the schematic is not considered practicable, the WD may include more than one schematic, but this should be done only when the advantages gained are considered to outweigh the disadvantages which include:

- Loss of schematic association
- Necessity for maintaining cross-references in the drawing index files.

Note: There should normally only be one WD issued for each schematic drawing. However, when a schematic is used with more than one equipment specification, then additional WDs may be issued to distinguish between distinct equipment designs.

2. Primary Requirements

The primary requirements for all WDs are that they be in agreement with the associated engineering requirements. This includes circuit drawings, general equipment requirements, and general requirements. Deviations from design requirements are permissible providing that such deviations are authorized by the designer and are fully explained by suitable WD notes. It is the responsibility of the manufacturer to confirm all agreements with the designer authorizing deviations and to remove the modification notes as soon as design information has been changed to incorporate those deviations.

Schematic drawings (also known as circuit) are prepared by the designer to portray the component, component connections, and requirements for a specific circuit, such as telephone circuit, trunk circuit, sender circuit, etc. The component and wiring conventions are designed to facilitate the tracing of circuit operation rather than the manufacture or physical appearance of the equipment. Circuit requirements consisting

of the mechanical requirements, circuit preparation, test set preparation, and direct current flow are shown in tabular form on the schematic drawings.

- See Bell Communications Research PUB 53304, Circuit Drawings, Requirement Tables, Circuit Descriptions, X-Specifications, Assignment Lists, for a description of conventional circuit schematic drawings (attached-contact type) and circuit descriptions (CDs).
- PUB 53304 describes the circuit requirement tables furnished with circuit drawings.
- A detailed description of detached-contact type drawing is covered in Bell Communications Research PUB 53329, Detached-Contact Type Schematic Drawings (SDs).
- Bell Communications Research PUB 53328, Symbols for Circuit Schematic Drawings, covers graphic symbols for circuit schematic drawings.

3. Titles

The title on the SD is reproduced without change on the corresponding WD drawing except where deviations are necessary to provide suitable titles when more than one WD is made from an SD. Where necessary, information for the proper indexing of the drawings may be added to the titles. The word "CIRCUIT" in the SD title should be changed to "WIRING DIAGRAM" to identify the content of the drawing (see Figure 6-F-A).

Figure 6-F-A Title on Single Sheet Wiring Diagram

On multisheet WDs, place the complete title on the first sheet and a condensed title obtained from the SD drawing on all supplementary sheets. For example:

Equipment product WDs carry manufacturer's ratings if appropriate.

Revision notes are shown in the Revision Note column. When necessary these notes may be continued in a second column to the left of the first, or on Sheet A2. Changes are covered in detail in revision notes as considered appropriate by the manufacturer.

Copy all revision notes including issue numbers, dates, and approvals shown on the superseded drawing one year prior to the current superseding issue, or as considered appropriate by the manufacturer.

Issue 1 and Subsequent Issues-Sheet 1 should be as shown in Figure 6-F-B.

Figure 6-F-B Approvals and Dates on Issue 1 and Subsequent Issue - Sheet 1 - Wiring Diagrams

Initials (Recommended):

- Draftsperson
- Drafting checker
- engineer
- Engineering supervisor

Second and subsequent sheet entry of drawing issue number should be as shown in Figure 6-F-C.

Figure 6-F-C Second and Subsequent Sheet Entry of Drawing Issue Number - Wiring Diagrams

The date of Issue 1 and all subsequent issues of WDs is the date of the highest level of approval required for the drawing issue. On multisheet drawings show the date on Sheet 1 only. Show the date of the originals drawing on retraced drawings and locate it at the top of the issue column in the same position as for new drawings.

4. Drawing Types-Equipment Product

When all the common information and wiring information can be fitted on one sheet, a single-sheet drawing is prepared. The common information is generally as indicated in Figure 6-F-D. The Sheet Index consists solely of a record of WD and circuit schematic drawing issues, and the words "Sheet Index" are not shown.

Note: When the reissue requires additional sheets, the pictorial information is relocated to separate sheets and all sheets are renumbered in the standard numbering plan.

Figure 6-F-D Recommended Arrangement of Common Information on One Sheet

The drawings are issued on a multisheet basis, with the first sheets shown as information sheets and the second group of sheets known as the pictorial sheets. The sheets are changed on an individual sheet basis and only the changed sheets are reissued. The sheet(s) containing the Sheet Index are reissued with every change. All reissued sheets carry the same raised issue number as the sheet(s) containing the Sheet Index. When additional sheets are required on reissues, the additional sheets issued have the same issue number as the other sheets changed for the reissue, and not indicated as Issue 1.

The information sheets (A sheets) normally consist of seven major categories listed in paragraph 4.06 of this Part.

The pictorial sheets (B sheets) are the second group of sheets on a WD and are numbered B1, B2, B3, etc., and cover the wiring and cabling. If a present figure is split into two or more figures, the new figure is added on the same sheet if space is available. When there is no space available, the figure is added on any sheet on which there is space, or a new sheet is issued.

All tables on WDs are assigned letter designations for locating information. There are three tables required on every WD. These tables are designated Tables B, C, and D, and they are described in paragraphs 8.01 through 8.09. Other tables provided on an as required basis use the assigned letters as specified in the remaining paragraphs of this Part.

Common information consists of the following items:

- Sheet Index
- Manufacturing notes
- Engineering notes
- Revision notes
- Schematic-wiring diagram cross-reference table
- Record of figures, components, and wiring changes
- Sheet locations of figures and options.

Note: Placement of these items on the common information sheets of the drawing may vary depending on the number of sheets required. Figures 6-F-D and 6-F-E illustrate recommended information arrangement for a drawing requiring one and three common information sheets, respectively.

Figure 6-F-E Recommended Arrangement of Common Information on Three Sheets

5. Sheet Index

A Sheet Index is prepared for all multisheet WDs. The Sheet Index lists all the sheets which have been issued for a drawing. The table also shows the record of equivalent issue between the schematic and WD sheets (see Figure 6-F-F).

If it is necessary to omit certain issues from a WD, show the highest schematic issue which is included with the designation "OMIT" (Issue No.) (see Figure 6-F-F, Schematic Issue 8). In cases where it is impractical to list all of the omitted schematic issues in the Sheet Index, space may be conserved by showing the highest schematic issue included with the designation "NOTE 77" and adding on Engineering Note 77 listing each omitted schematic issue (see Figure 6-F-F, Schematic Issue 12).

When all spaces within the issue column have been used and another entry is required, the spaces are recycled retaining the first issue and the last five issues. Leave a blank space between the first issue and the new entry.

6. Manufacturing Notes

Information required by the manufacturer, the installer or both, which cannot be conveniently included in the body of the drawing is placed under the heading MANUFACTURING NOTES which should be numbered from 1 up. In addition, all graphical or letter symbols used in the body of the drawing are defined in these notes.

Figure 6-F-F Sheet Index

Notes concerning wire gauge and type, such as 22BU, and method of wiring, such as SWI, appear first in the set of notes. Notes specifically referred to on wiring figure sheets include the wiring figure sheet number.

INSTL (installer) and SHOP columns are provided to the left of the manufacturing notes. In either or both columns, an X is placed depending on whether the note specifically applies to the shop, the installer, or both.

Show references to specific manufacturing notes at the affected figures or leads and mention the figures, component description, or location numbers in the notes to permit ready reference without searching the drawing. If the note covers a variation in wiring depending on testing requirements which are covered in detail on the schematic, include in the note a phrase, such as, TO BE CONNECTED BY THE SHOP OR INSTALLER DURING SHOP OR INSTALLATION TEST. The wording of the note in this manner serves a double purpose. It indicates that the wiring is not to be connected during wiring operations but is to be left open for connection during the testing operation. It also indicates that the requirements for the connection of the leads are covered with other testing requirements in the schematic. For this reason the inclusion in the note of detailed testing requirements serves no useful purpose and may necessitate changes to keep the note in step with schematic changes which would otherwise be unnecessary.

Appendix I of this Publication, entitled Manufacturing Notes, contains a complete list of manufacturing notes and covers wiring symbols, abbreviations, and definitions.

7. Engineering Notes

Engineering notes cover information associated with the WD for the use of the engineering group. On WDs, engineering notes are numbered, starting with 51 and include the number of the associated equipment drawing, a list of connecting drawings, modification notes, and when required, information on the application of figures and options.

Note 51 on WDs refers to the Sheet Index for information on drawing(s) from which the WD is made.

ENGINEERING NOTES

51. SEE SHEET INDEX FOR DRAWING(S) FROM WHICH THIS DRAWING IS MADE

- When the WD is of the single-sheet variety, Note 51 is in table form as follows:

- All drawings that show connections to a WD by any means other than jacks, plugs, or cross-connections are listed by title and number under Engineering Note 52. If there are no connecting drawings, the word "NONE" is shown. For example:
 52. CONNECTING DRAWINGS NONE
 52. CONNECTING DRAWINGS
 TOLL TEST BOARD NO. 17C JACK CKT
 T-XXXXX-XX
- List in Note 52 all of the connecting drawings which were known or considered when the initial issue of the WD was prepared. However, it is not always practicable or desirable to include in the list of connecting drawings all of the drawings which might be connected. Additional drawings should be listed if those drawings are required for reference or information.

Engineering Note 53 refers to the equipment drawing(s) associated with the WD. The standard equipment arrangement and associated specification drawings, when existing, are listed. For example:

53. EQUIPMENT ARRANGEMENT JOOOOIA-1

53. EQUIPMENT ARRANGEMENT ED-00000-00

Whenever the Sheet Index shows the designation "MOD" applied to a circuit drawing issue, a separate engineering note (76) is shown explaining the deviation from the issue. For example:

76. MODIFICATION OF SD-XXXXX-01, ISSUE 3 CONSISTS OF TERMINATING THE LEAD FROM 3T (A) REL ON TERM. 6 OF (CR) TS INSTEAD OF ON TERMINAL 7.

76. MODIFICATION OF SD-XXXXX-01 CONSISTS OF USING TERMINAL 51 FOR BA LEAD TO ALARM TRUNK.

76. MODIFICATION OF SD-XXXXX-01 CONSISTS OF USING X WIRING INSTEAD OF Y WIRING IN FIG. 2.

Note: The designation "MOD" is shown with a schematic issue number only when there are deviations between a WD and schematic issue other than the omission of intervening schematic issues. Where possible, Engineering Note 76 is written in terms of figures or options in order that the note be as short as possible, while still containing adequate information.

When deviations from a schematic represented by modifications are eliminated, enter in the Sheet Index table the highest schematic issue number included without a designation and remove the associated explanatory Engineering Note 76.

At times, changes on an SD circuit drawing do not result in changes on the WD. When a later circuit drawing change results in a change on the WD, the earlier circuit issues that did not affect the WD are shown with the word "OMIT" in the same block with the new circuit issue. When it is impractical to list all the omitted circuit issues, an engineering note (77) is added to cover this information.

When deviations from a schematic represented by omissions are eliminated, enter in the Sheet Index table the highest schematic issue number included without a designation and remove the associated explanatory Engineering Note 77. A record of the Engineering Note 77 should be preserved in the Issue column.

8. Tables

Table B with figure, component, and wiring changes is shown for all WDs.

Indicate the automatic application of WD figures and options by means of suitable entries in the columns titled E OFFICE RECORDS, DO NOT SPECIFY, THIS OPTION WAS FURNISHED. In the above, the term "option" includes both figures and options. In every case where the automatic application is dependent on whether or not a controlling figure is specified, list the controlling figure in parentheses. For example, FIG. HA may be automatic when FIG. HB is not specified, but this is true only when the controlling FIG. 2 is specified. Indicate this fact by editing the item. An additional entry is sometimes required to explain the automatic application of an option which is included within another option. For example, if the circuit designer breaks an X option out of a schematic and this X option includes an E option representing the previous condition and an F option representing the new condition, edit the item as follows:

- When the looping of leads at unequipped component positions identifies a schematic option which is not designated on the WD, edit the item as an automatic option; for example, if the WD shows L components with certain associated connecting lead-s designated LP, the looping of these leads when L components are not furnished constitutes M wiring on the schematic.

A schematic-wiring diagram cross-reference table, Table C, is prepared for all WDs.

When WD figures and options and SD figures and options are similarly designated, no entry is required in the table.

Note: The cross-reference table in addition to furnishing information for determining schematic figures furnished in a specific circuit is also used by the Operating Telephone Company in determining the WD figures.

There are certain kinds of WD figures and options which either cannot be translated into schematic data, or whose translation LS not required by the telephone company personnel. The following are example of WD data, the translation of which word be either impossible or misleading:

- Wiring only figures which require components in order of function.
- Universal wiring which may be equipped in accordance with two or more different drawings or figures.
- Optional wiring which is furnished and connected at one end to a common (nonoptional) component, but the associated optional component is not furnished
- Locally assigned options which have no counterpart in the schematic.

Since telephone company central office records covering the application of the following kinds of figures and options are not required, these figures and options should not be listed in the cross-reference tables:

- Cross-connection figures and any associated option, whether or not they are shown in parentheses ().
- External circuit connections such as battery or ground supply when they are part of the internal wiring of a unit or panel.
- Option for which office wiring list records are not required (Nonrecord Options).

Listing Entries:

- List each WD figure and option on separate lines and allow sufficient space for all associated schematic information.
- Opposite each WD entry, list the schematic figures, options, or figures and options which are furnished either wholly or in part whenever that WD entry is specified.
- No attempt is made to describe the portion of the schematic figure or option included in a WD entry in cases where that entry does not include the entire schematic entry.

~ Show dashes (-) in the schematic columns opposite the WD option in all cases where schematic information is not furnished and explain under REMARKS.

Enclose in parentheses () any data which is shown for information only and is not to be recorded on the telephone company central office records.

- The showing of parenthesized information which is not required by the engineering group in translation work is limited to information which is not readily obtainable from an inspection of the drawing and is essential in other phases of engineering. For example, there is no advantage in indicating that X wiring is in Figure 1 of the WD if the WD includes only a single figure.
- Explain the significance of parentheses by means of a note reading as follows:
ITEMS IN PARENTHESES () ARE FOR INFORMATION ONLY AND ARE NOT TO BE RECORDED ON TELEPHONE COMPANY CENTRAL OFFICE RECORDS.

Note: Parentheses are also used to indicate the controlling figure in cases of automatic application.

Table D is a tabular chart showing the sheet location of figures and options and is prepared for all WDs using the multisheet format.

14	12		5 6 7 8 9 10
13		X	7
12		Y	3
11		W	4
10		T	4
9	11		4
8	10		4
7	9		4
6	8		4
5	7		4
4	6		4
3	5		3
2	4		2
1	1		1
LINE	FIG	OPT	R SHEET
TABLE D - SHEET LOCATION OF FIGURES AND OPTIONS			
	DA	DB	DC

Provide complete and definite engineering information as to the application of figures and options by means of an engineering note or engineering table, Table E.

	EA	EB	EC	ED	EE	EF	EG
TABLE E - FEATURES - SEE NOTE							
ITEM	SD ISSUE	DESCRIPTION	FIG	WRG	SPECIFY APP	QUANTITY	REMARKS
1		FOR ONE MULTIFREQ PULSING SENDER UNIT	1			1	
2	2D	PROVIDES CONTACT PROTECTION		A	A	1	MO SEE ITEM 4
3	3D	PROVIDES IMPROVED PERFORMANCE AT U TYPE REL			ZA, ZD, ZF		
4	3D	PROVIDES ADDITIONAL CONTACT PROTECTION ONLY WHEN W APP IS FURNISHED ONLY WHEN Z,V, T, S, R, Q, P, N, M, K, ZX, X, Y APP IS FURNISHED		B	B ZM ZI,ZN,ZD, ZP,ZP,ZS, ZW,ZL,ZX		
A		NUMBER SERIES SDR - LINK SIGNAL INDICATION IS (MULTI-OFFICE PLAN 1) DETERMINED BY (5 DIGITS RECEIVED) EXTRA KEYED DIGIT (5 DIGITS RECEIVED COMBINATION OF SDR- LINK SIGNAL & EXTRA KEYED DIGIT (4 OR 5 DIGITS RECEIVED) COMBINATION OF A SIGNAL FROM INC LK FR OR FROM AN EXTRA KEYED DIGIT (4 OR 5 DIGITS RECEIVED)		OMIT HA	Y, ZK W,ZM W,ZM ZX,ZY W,ZM X,ZL	1 1 1 1	

When Table E is used, assign each feature or option as an item. Identify the common feature by numbers and the optional features by letters and explain with an engineering note reading as follows: ITEMS DESIGNATED WITH NUMBERS ARE COMMON FEATURES; ITEMS DESIGNATED BY LETTERS ARE OPTIONAL FEATURES.

Designate each item, figure, and option which is not covered by the associated Equipment Manufacturing Specification lists with an asterisk and explain with an engineering note reading as follows: ITEMS DESIGNATED WITH AN ASTERISK* CONTAIN FIGURES OR OPTIONS REQUIRED BUT NOT COVERED ON ASSOCIATED STANDARD EQUIPMENT MANUFACTURING DRAWINGS.

A fuse requirement table, Table F, is prepared when required.

A cabling table, Table G, is prepared, when required, for all cables with a cabling designation. Each cable is assigned an item number from 1 up.

A distributing frame table, Table H, is prepared when required.

An interrupter requirements table, Table J, ~ prepared when required to specify the interrupter requirements of the circuit.

9. Component Location Tables

Component Location Tables list the location on the circuit drawing, on the WD, and in the equipment of all the components, including terminal strips, shown on the circuit drawing. These tables are prepared as part of WDs for marker, decoder, trouble indicator, sender, step-by-step identifier, routine test, and similar large equipment. Dimensions of the table and typical entries are shown in Fig. 6-F-G and 6-F-H.

Method of Preparation and Arrangement:

- The tables are shown on separate WD drawing sheets containing no other common information.
- The tables begin in the upper left of the sheet and proceed from top to bottom and from left to right on the sheet. Headings are repeated at the top of each table.

LINE	COMPONENT DESIGNATION	FRAME POS	J 00000 UNIT	SK	CKT SCHEM SD-00000-01				WRITING DIAGRAM		REMARKS
					APP SHEET	CKT REQ FIG.	SHEET	PAGE	T-00000-31 SHEET	LOC. NO.	
1455	RELAYS										
	XTRL	A	BB	B	22	30	F17	33	132	03	
	XTS	A	BA	B	21	29	F17	33	134	22	
	XTSI	A	BB	B	22	30	F17	33	132	08	
	XTV	B	DB	B	26	40	F17	33	130	76	SEE NOTE 17
1460	XUGB	A	BA	B	21	29	F17	33	134	28	
	RESISTORS										
	ANA	B	C1	B	26	40			180	14	
1465	ANI	F	FC	A	39	63			221	48	
	ANKO-8	F	FB	B	39	61			223	43-51	
	ARNO	D	EA	A	33	59			213	22	
	ARNI	D	EA	A	38	59			213	34	
.50	1.50	.62	.50	.50	.74	.50	.74	.50	.50	1.00	2.00

Figure 6-F-G Component Location Table - Dimensions and Typical Entries Shown

- Equipment headings in the table may be varied depending on the type of equipment involved. Component location information under these headings should be sufficiently explicit so that the equipment drawing need not be referred to when changes are made on the equipment.
- Line numbers proceed consecutively from the numeral 1 at the beginning of the first table to the end of the last table.
- Component categories are listed in the following order: relays, resistors, and capacitors followed by the remainder of the component categories in alphabetical order. The component category is indicated at the top of each table.
- Component designations within component categories are listed alphabetically or numerically. number-prefixed designations precede letter-prefixed designations.
- Blank lines are left at the end of component categories and also within extensive categories such as relays and resistors.

- Prepare the tables in accordance with the examples in Figures 6-F-G and 6-F-H.

- Although the following detailed information applies directly only to drawings prepared in accordance with Figure 6-F-H, Sketch A, there should be no difficulty in extending those methods to other arrangements because the headings are generally self-explanatory. Arrange the data in vertical columns under the following headings:
- Lines: Number the lines consecutively from top to bottom and sheet to sheet, allotting a number to the space for each horizontal Line. Show the number of the first line on each page and every fifth line thereafter. When changes necessitate additional listings for which space in the normal location is not available, start a new sheet for the added components and place a reference note at the bottom of the sheet on which the components would normally be shown reading: FOR ADDITIONAL COMPONENTS SEE SHEET. Show a heading at the top of each column and over each component group, indicating the kinds of components.
- Component Designation: List the component in each group by the functional designation in alphabetical order. If two or more components have a common functional designation (except for a numerical suffix) such as, CBA-1, CBA-2, CBA-3, CBA-4, and CBA-5, list the group as a single item thus: CBA 1-5, if the component is not scattered on the schematic or WD.
- Casing Number and Mounting Plate Number The casing number and mounting plate number should be shown to fix the location of the components on the frame without requiring reference to the equipment drawing. If the component is mounted under a casing, show an arbitrary casing number and mounting plate number and explain the numbering scheme with an engineering note reading as follows: LOOKING AT THE FRONT OF THE FRAME CASINGS, NUMBER BOTTOM UP AND LEFT TO RIGHT OF BAYS. MOUNTING PLATES IN EACH CASING NUMBER BOTTOM UP.
- Mounting Plate Sketch: Enter the letter designation of the mounting plate sketch of the equipment drawing. If the equipment is mounted under a casing, this information will serve only to locate the component on the equipment drawing. If the equipment is not mounted under a casing and the sketch designation is stenciled on the frame, it will also serve to locate the component on the frame. In cases where the equipment is not mounted under a casing and the sketch designation is not stenciled on the frame, additional information is furnished under REMARKS, similar to the following to indicate the approximate position of the component on the frame:

TOP OF COMMON BAY
BOTTOM OF ROUTE RELAY BAY
MIDDLE OF COMMON
MISCELLANEOUS RELAY RACK

- Schematic, Sheet and Location: Enter the schematic number, sheet number on which the component is shown, and location of the component on the schematic by means of the schematic coordinates.
- Schematic Circuit Requirements Sheet: Enter the sheet of the schematic showing the circuit requirements of the component in all cases where such information is shown on the schematic.
- Wiring Diagram Sheet Number and Location Number Enter the WD and associated WD component location number of each WD showing the components.
- Remarks: In the this column enter any other information which would be helpful in identifying the circuit or locating the components as covered elsewhere in this document.
- Components from other drawings: If components are listed which are shown on a schematic or WD having a different number than shown in the page headings or on a WD having a 6-digit number, enter the schematic and/or T-drawing number on the next line as illustrated in Figure 6-F-H, Sketch A, line 71. If reference to a single schematic is required on many entries, chart space may be conserved by designating the associated schematic sheet and wiring diagram sheet entries with an asterisk and explaining with an engineering note reading as follows:
SCHEMATIC SHEET AND WIRING DIAGRAM SHEET NUMBERS MARKED
WITH AN ASTERISK REFER TO THE BASE NUMBER.
- Changes on Component Location Tables: Make all changes outright without preserving any detailed record of the information shown on previous issues.

10. Component Symbols

Components mounted in a horizontal or vertical arrangement are shown on the drawing in the same horizontal or vertical arrangement. When the size of the drawing sheet does not permit showing each arrangement completely, the components may be shown in two or more horizontal or vertical rows. When the equipment drawing specifies several mounting arrangements for the same circuit, a separate figure is shown for each arrangement.

Space is reserved in the component layout for unequipped mounting plate positions so as to provide for future additions.

Components are represented, in general, by rectangular symbols. Pigtail-mounted, in general, by rectangular symbols. Pigtail-mounted components may be shown as rectangles of varying sizes according to need and available space. Show components by means of conventions which in general simulate the appearance of the components as viewed from the wiring side. Insofar as practicable, show each component in its approximate location with respect to other components, following the standard equipment arrangement in all cases where such an arrangement is available. If the equipment arrangement requires the mounting of components in other than the

normal position, show an explanatory note for ordering information such as mounted upside down. If the standard equipment arrangement specifies two or more mounting positions, show a separate WD figure for each mounting position. Use conventions of the following dimensions insofar as practicable.

- Rectangular component convention: 1.25 inch high and as long as required.
- Relay and similar component terminals: On 0.25 inch centers where lettering of 10 characters per inch is used.
- Feed lines: 2.25 inch long.
- Terminal strip terminals: On 0.50 inch centers where lettering of 10 characters per inch is used.

With the exception of terminal strips, terminal circles are shown within the component symbol in the arrangement in which the terminals appear when viewed from the wiring side. Terminal circles are not shown for the terminations of pigtail-mounted components.

Terminals of terminal strips other than those on distributing frames are shown as circles arranged in a horizontal line or lines across the upper portion of the sheet. When convenient from a wiring standpoint, the circles are grouped so as to conform to the stitches which serve particular groups of terminals. If this is not desirable, the grouping most convenient is shown. Local or "Shop Side" wiring is shown as feed lines running downward from the circles, and external wiring is shown as feed lines running upward from the circles. Show the location of terminal strips when the location is not apparent, and show the codes only when they are not subject to variation. Show all terminals of a terminal strip insofar as practical including unassigned terminals. For distributing frame terminal strips, only the portion of strip to which connections are made is shown. Terminal strips to which the external wiring is to be connected are shown on one sheet, if possible. Other components may be shown below the terminal strips when space is available on the same sheet.

Terminal strip terminals are drawn on 0.50 inch centers. Templates provide for terminal spacing of wire-spring relays, while terminals of all other relays are spaced on 0.25 inch centers. Variations are permitted to accommodate special conditions.

Show symbol designations with appropriate notes as required to indicate the position of the terminals on the terminal strip. Following are typical examples.

B - TERMINAL NEAREST BASE OF TERMINAL STRIP. (RIGHT OR BOTTOM TERMINAL FOR TERMINAL STRIPS THAT HAVE TWO FANNING STRIPS).

B1 - TERMINAL NEAREST MOUNTING PLATE OR PANEL. B2-LUG NEAREST BASE OF TERMINAL STRIP.

E - ADJACENT ROWS (PERPENDICULAR TO THE FANNING STRIP) OF TERMINALS

K - TOP OR LEFT ROW (PERPENDICULAR TO THE FANNING STRIP) OF TERMINALS

K1- TOP OR LEFT TERMINAL ON 203 AND 700A TYPE TERMINAL STRIPS

K2 - TOP LEFT TERMINAL ON 224 TYPE TERMINAL STRIP LOOKING AT LOCAL CABLE SIDE OF STRIP

K3- BOTTOM LEFT TERMINAL ON 224 TYPE TERMINAL STRIP LOOKING AT LOCAL CABLE SIDE OF STRIP

K4 - RIGHT-HAND TERMINAL LUG LOOKING AT REAR OF TERMINAL STRIP

Designate component terminals to agree with the schematic.

When leads are terminated on surplus terminals of components, the connection is indicated with the symbol DU.

Crossbar switches are shown with 10 horizontal levels of contacts and 10 vertical units on one sheet. A switch with 20 vertical units is shown on two sheets.

The symbol for a jack is a rectangle. For singly and strip-mounted jacks, the terminal circles within the rectangle are arranged and numbered according to manufacturer's conventions. This also corresponds with the numbering shown on the circuit drawing (Figure 6-F--). After the arrangement and numbering of terminals for these jacks has been established on this basis, the symbol as a whole may be oriented according to the mounting position indicated on the equipment drawing. For other types of jacks, the left-to-right and bottom-to-top numbering rule based on component orientation in the equipment applies. Symbol terminals are staggered, if this is representative of the physical arrangement of the terminals as seen from the wiring side.

Figure 6-F-J Jack Symbols

The symbol for a key is a rectangle (see figures 6-F-K, L, M). The terminals are arranged according to the manufacturer's conventions and numbered according to the circuit drawing symbols. Quadrant letters prefix the terminal numbers of lever-type keys. The entire key symbol is oriented as shown on the equipment drawing. Lever-type key terminals are arranged in rows, but those of turnbutton-or pushbutton-type keys are staggered.

In general, keys are mounted on hinged shelves with the front to the right or bottom or nearest the operator. The position of the front of the key is indicated by the key top view on the schematic. Key conventions are placed on the WD to show the key in the wiring position. Caution should be exercised in the case of keys mounted on hinged or movable mountings to determine the position of the terminal side of the key in the soldering position.

Figure 6-F-K Lever Type Key**Figure 6-F-L** Turnbutton-Or Pushbutton-Type Key**Figure 6-F-M** Multiunit-Type Key

Show key top views as required on WDs to cover key codes, functions, etc., which are not shown on the associated schematic.

When more than one key with a nonsymmetrical pileup of the SAME code and SAME function is used in a circuit and the keys are to be mounted in diametrically opposite positions, the key terminals are numbered the same regardless of mounting orientation. Example:

KEY	FUNCTION	NUMBER
Top Mtd	A	J1234
Bottom Mtd	A	J4321

When more than one key with a nonsymmetrical pileup of the SAME code or type but DIFFERENT function is used in a circuit and the keys are to be mounted in diametrically opposite positions, the key terminals are numbered left to right regardless of mounting orientation. Example:

KEY	FUNCTION	NUMBER
Top Mtd	A	J1234
Bottom Mtd	B	J1234

If the SD does not agree with the above, the circuit designer should be requested to change the SD; otherwise, Note 76 should be added on the wiring diagram.

When an insulated terminal punching is mounted under the relay mounting screws, the terminal(s) are shown in the relay symbol, preferably in the left-hand stitch. Insulated terminal punchings are used as doubling up points for leads to avoid splicing or to avoid the congestion which would result if an excessive number of leads were brought into a component terminal. Show insulated terminal punchings on WDs in their approximate locations with respect to their associated components. If the terminal punching is to be mounted in the same mounting position with other components, show the terminal punching convention on the center line within the component convention in a position to be determined by the drafting department. The position of the terminal punching convention will depend on the method of bringing the leads out of the component convention, the lead colors, local cable stitches, interference with component designations, etc.

Designate terminal strip and miscellaneous punchings to agree with the schematic drawings and charts. If the same figure or circuit is used more than once in the same position or in other positions, and the punchings require a different numerical assignment, show the punching numbers in a table located as near as possible to the punchings as follows:

- On circuits (as auxiliary signal) which are specified for each panel, the table indicates the punching numbers for the left, right, and middle panels instead of the circuit numbers shown in the above example.
- If a circuit or figures are used in different types of positions and different punching assignment are required, the table for each position is given in a lettered figure and reference made at the punchings as follows: SEE FIG. HA OR FIG. HB AS SPECIFIED. Explain the use of lettered figures in an engineering note.

11. Component Sketch

When it is necessary to show connections for alternative codes, the symbol is repeated as a sketch SK A, SK B, etc., (Fig. 6-F-N). This sketch shows the component symbol, option, wire colors, pairs, live wire information, etc., but does not include either a base line bracket or feed line terminating numbers. The information shown in the sketch, for example, wire colors, conforms to information given for the code shown connected to the WD.

Figure 6-F-N Method of Showing Alternative Components with One Component Shown Connected in Circuit and One Component Shown in Sketch

Components on an equipment product WD are identified by functional or reference designation, code, and descriptive name. The identification is generally arranged within or adjacent to the component as shown in the following:

(R) (Functional or reference design)

18BH (Code)

RES (Descriptive name abbreviated)

When only one terminal strip is shown, the functional or reference designation is omitted. The abbreviation "REL" for relays is not shown except where it is felt confusion would result if it were omitted. When two or more components are shown by a single symbol, as an electron tube and socket, the code and descriptive name of each is given. For components not covered by apparatus code or KS specification, the manufacturer's name and catalog description are shown.

When a coded component is available in different electrical values, the particular value desired is specified as follows:

(R3) RES

KS-13490, L3

33k

Resistor, capacitor and inductor values are indicated.

When resistance or capacitance abbreviations or component codes are generally applicable throughout the drawing for a quantity of components, the abbreviations or codes are not shown at or in the component symbol, but are covered by a general note instead. For example:

MANUFACTURING NOTES

UNLESS-CC OTHERWISE SPECIFIED RESISTANCE VALUES ARE IN OHMS,
CAPACITANCE VALUES ARE IN PICOFARADS.

On WDs, the rated voltage of components, except meters, is shown as single values rather than as the maximum and minimum voltages shown on the circuit drawing. Fuse ratings in amperes (A) are also indicated.

Designate coded equipment, such as, machines, panels, etc., with the specification and list numbers, for example: KS-23455, L1 AND L3: PANEL PER J93802A, etc.

The following method is used in changing component codes on WDs:

- Add the schematic option to the replaced code.
- Add the replacing code with its optional designation. If the replacing code requires a different component convention or connections, show the replacing code connected in the circuit and add an apparatus sketch showing the replaced code and connections as shown in Fig. 6-F-N.
- If space considerations or the condition of the tracing render the above-mentioned (a) and (b) method impracticable, leave the replaced component connected into the circuit and show the replacing component in the associated sketch. In some cases, both the replaced and replacing codes can be covered by a single component convention by adding a designation, such as, SHOWN ONLY ON X COMPONENT, to certain terminals. This is done where practicable in preference to the addition of a component sketch.
- If a change in component codes DOES NOT require optional designations for record purposes, draw a light line through the replaced code and show the replacing code beside it. Engineering notes are not usually required to explain the significance of LINED OUT components on WDs since it is understood that the

replacing codes are specified for new work. If, however, the replacing code should not be specified for all new work, add a reference to an engineering note explaining the application of the replacing components.

A component code is considered as being REPLACED when:

- A REPLACING (different) code is specified to perform the function of the replaced component on new work.
- The REPLACED code should be retained on the WD for record purposes.

Components are replaced in order to permit improvements in manufacturing methods, service life, maintenance, etc. Two components are interchangeable if they are electrically and mechanically equivalent, that is, they perform the same functions, have the same component convention, mounting arrangement, terminal designations, terminal arrangements, etc.

Schematic options are assigned by the circuit designer to both the REPLACED and REPLACING component codes. Schematic drawing changes involving the substitution of nonidentical component codes without optional designations are referred to the circuit designer for the assignment of options.

12. Component Location Numbers

Component location numbers are assigned as follows:

- Assign arbitrary location numbers to each component or any desired division thereof and to brackets. Show the location numbers in large figures, 3/16 inch lettering. Assign numbers from 11 to 99 on each sheet in consecutive order left to right and top down except on sequence switches, multicontact relays, and components numbered right to left or bottom up, in which case assign in that order. In case a single mounting place location is assigned on the equipment drawing for one of two or more different pieces of optional components, assign the same component location number to each component even through it may be shown in separate figures or sketches. With this exception, component location numbers are not duplicated on a WD.
- Reserve component location numbers for unequipped mounting positions. Consideration should be given to the reservation of component location numbers for future requirements, i.e., for brackets, miscellaneous component assignments, etc. which may be required for changes.
- If it is necessary to add components in spaces for which location numbers have not been reserved, assign to the added component, the location number of an adjacent position with a number suffix thus 12-1,12-2, etc.
- If more than one component location number is assigned to a single component, it is essential that the association between component location numbers and

component terminals be clearly indicated in order to facilitate the tracing of connections and the assignment of wire colors.

- For connections beginning and terminating on the same sheet, the feed Line terminating number consists of the applicable component location number to which the feed line is directed.
- For connections that begin on one sheet and continue or terminate on another sheet, the feed line terminating number consists of the number of the sheet to which the line is directed followed by the applicable component location number. Thus, terminating number 3319 indicates that the wire run connects at component location 19 on Sheet B33.

When one or more figures are required in addition to the main figure to cover optional features or improvements, the components in these figures are generally assigned location numbers in regular sequence in accordance with component mounting positions. If components of two optional figures mount in the same position, both components are assigned the same location number. Connections may then be shown between the main figure and optional figures, either through base lines or through brackets, as though the optional figures were part of the main figure.

Although a location number is not always indicative of a stitch, in general, no color is duplicated within a group of wires associated with a location number. Components with many terminals should be divided into groups consistent with stitching requirements and a location number assigned to each group. When the terminals of a component, usually a terminal strip, are not shown grouped according to stitches, the location number may be disregarded in assigning colors.

For the U-, Y- or similar type, relay, show a second component location number with the component convention if the number of terminals in the row with the greatest number of terminals exceeds seven. Indicate the association of component terminals and location numbers by showing a wider space between terminals where the second component location number is shown, and place them directly opposite each other to approximately divide this row of terminals equally between the two location numbers. If this row includes an odd number of terminals, associate the greater number of terminals with the left component location number (see Figure 6-F-P). In order to provide for the possible replacement of a relay by a different relay with a greater number of terminals, reserve a second component location number in each case where a single number is assigned.

○ ○ ○ ○ ○ ○ ○ ○ ○ ○

Figure 6-F-P Location Numbers and Stitch Relationship In U-Type Relay

When wire-spring relays are connected to cable arms in a horizontal position, three stitches are shown for the conventional relay and four stitches for the type with 24 make contacts.

For wire-spring relays connected to cable arms in a vertical position, two or three stitches may be indicated, but no more than fourteen usable terminals are included in any one stitch. Individual, fixed-spring terminals are not regarded as usable unless the associated make or break terminals (or both) are present. For methods of indicating two and three stitches, see Figure 6-F-Q. When two stitches only are necessary, an extra number is reserved for possible future replacement of the relay by one requiring three stitches.

Figure 6-F-Q Stitch Indication for Typical Wire-Spring Relays Connected to Cable Arms in Vertical Position

13. Figures

A WD figure usually represents the connections of the associated circuit or apparatus figure.

Whenever possible, WD figures are designated to agree with the circuit figures of the conventional-type circuit drawing or with the apparatus figures of the detached-contact-type-drawing. On 6-digit T drawings, assign the numbers f from one up disregarding the schematic numbering. For example: Fig. 2, 3, and 8 of the circuit drawing are always required for a particular equipment order and are, therefore, included for convenience in one WD figure designated "FIG. 2." In this case, correspondence of the remaining circuit and WD figures is illustrated in the following.

- When the size of the figure requires that it be shown on more than one sheet, the second and subsequent appearance of the figure will be designated, for example, as FIG. 2 CONT.
- On installer's and cabling figures where the same figure is shown on more than one sheet, designate each appearance of the figure as being continued. For example:

If Figure Appears On Two Sheets

1ST APPEARANCE
FIG. H1 (CONT A3)

2ND APPEARANCE
FIG. H1 (CONT A2)

Figure Appears On Three Sheets

1ST APPEARANCE
FIG. H1 (CONT A3, A4)

2ND APPEARANCE
FIG. H1 (CONT A2, A4)

3RD APPEARANCE
FIG. H1 (CONT A2, A3)

- Within the Operating Telephone Companies of U S WEST, cabling figures or other assigned by the manufacturer are assigned with the letter H starting with H1 for switchboard cabling figures (installer's outside of unit wiring) and HA for any figures other than cabling figures that are manufacturer-assigned.

Optional conditions may be shown as separate figures, generally designated FIG. A, FIG. B, etc. A lettered figure is a secondary figure that can not be specified without a numbered figure.

When connections are required between two figures on the same or on different sheets, the terminations and lead identification information should be shown in each figure. In order to avoid the possibility of listing such leads twice (once under each figure), information should be furnished to show from which figure the leads are run. The figure from which the leads are considered as being run is termed the controlling figure and the figure to which the leads are considered as being run is termed the NONCONTROLLING figure. For example, if FIG. A and FIG. B represent options associated with FIG. 1, the leads between FIG. 1 and FIG. A are specified and the leads between FIG. 1 and FIG. B will be required only when FIG. B is specified. In this case FIG. A and FIG. B are controlling figures, and FIG. 1 is the noncontrolling figure. The method of designating such leads to indicate the controlling figure is covered in a subsequent paragraph.

If applicable, show the rating of all figures which have a rating DIFFERENT from the rating of the drawing. Designate figures and associated notes which are not to be specified on future work "Mfr Disc." It is unnecessary to add a note to explain such a change in rating, for example, FIG. 6 (MFR DISC.), FIG. C.

The figure designation such, as FIG. 1, FIG. A is shown slightly above the figure. The character size for figure designation is 3/16 inch.

Arrange the figures on the tracing to indicate their importance and association and also to make the most economical use of the space. This will generally be accomplished by placing the principal figures toward the top and center of the tracing and showing the secondary figures at the sides and bottom. Place the secondary figures as close as possible to the point of connection to the principal figures when the connection is indicated by means of bracketed stubs.

An added new figure replacing an existing optional figure is located on the first available sheet with room.

The base line method and the bracket method may be used to show connections between figures. In the bracket method, feed lines are brought out from a base line to a bracket and destination indicated at the bracket.

The base line method of connecting figures, whether basic or optional, is used whenever possible. Bring leads to the base line and show component location number on which the leads terminate.

Figures are connected by means of brackets only under the following circumstances.

- When the figures are on drawings with different drawing number bases.
- When terminations are variable and the listing of location numbers on feed lines would result in a crowded layout.
- To avoid showing the same notes at many individual feed lines.
- Where the grouping of leads as stubs would simplify the drawing or avoid the repetition of running information, notes, etc.
- Where connection is or may be made with switchboard cable.

Methods of showing brackets depend on whether the bracketed connections are to be made directly to components or indirectly through terminal strips.

- Brackets that contain direct connections between figures are shown as indicated in Figure 6-F-R. No more than ten feed lines are grouped under one location number.

Figure 6-F-R Bracketed Feed Lines

- Bracelets that contain external connections to terminal strips may be shown in several ways. Particularly applicable to small circuits are the method(s) shown in Figure 6-F-S. For large circuits, an entire sheet may be devoted to showing external connections. In such instances, the drawing should be organized with respect to the type and number of terminal strips to be shown, the number of circuits served by each terminal strip, supplementary cables, if any, between terminal strips, etc.

Figure 6-F-S Methods of Showing External Connection In Brackets

Bracelet Destination Indication:

- For connections between figures on the same drawing sheet, the destination of the bracketed lines is indicated; for example, TO FIG. 2.
- For connections between figures on different sheets, the sheet and figure number is indicated; for example:
TO SHEET 38, FIG. 14 or (on revisions only of old drawings not in multisheet form)
TO T-00000-00, FIG. 5.
- For connections between drawings with different drawing number bases, the title of the circuit to which the bracketed lines are directed is indicated; for example: TO OSCG CKT.
- If (b) and (c) apply optionally to the same bracket, the instructions contained in both subparagraphs are followed.

Controlling and noncontrolling figure brackets:

- The controlling figure bracket is designated TO -- (These wires are connected whenever this figure is specified.)
- The noncontrolling figure bracket is designated FROM -- (These wires are connected only if the controlling figure is specified.)
- If the control of the connecting leads is variable, that is, in some cases they are to be run FROM the stubs and in other cases they are to be run TO the stubs depending on the methods used in preparing the connecting drawing, show the stubs with both a TO and FROM designation similar to those shown in Figure 6-F-T.

Figure 6-F-T Variable Figure Brackets

14. Universal Wiring Figures and Associated Equipment Figures

Universal wiring figures showing wiring only, to be equipped in accordance with other figures, are prepared by the same methods that are used in preparing fully equipped figures except for the omission of the circuit components. Show the terminal strips (if furnished) and all component location numbers. Show the leads to each piece of circuit component terminated at the position of that component bracketed with a designation, such as, TERMINAL AT POSITION OF (L~ RELAY.

Equipment figures for use with universal wiring figures furnish complete information on all leads that are to be connected so that leads may be traced for maintenance through their entire length without references to the universal wiring figure. It is not necessary to show in an equipment figure wiring which is not connected, but may be included in the local cable for connection when other figures are specified.

15. Options

Whenever possible, assign numerical and lettered options to agree with those of the circuit drawing. If additional options are required for manufacturing purposes or if a schematic variable is not assigned a lettered or a numbered option by the circuit designer, the manufacturer assigns an option. Show optional designations on the WDs at each optional point of connection. All options have either a record or nonrecord status.

Record options are those which Operating Telephone Company records should be maintained. All schematic options are record options unless otherwise indicated in an information note on the circuit drawing. Record option designations are enclosed in a double circle. The diameter of the outer circle is 0.50 inch, and the inner circle 0.25 inch, approximately. The double circle may be elongated to accommodate multiple designations.

Nonrecord options are those for which central office records need not be maintained. The status of these options is indicated in an information note on the circuit drawing. Nonrecord option designations are enclosed in a 0.25 inch square. These options consist of minor wiring variations as follows:

- Different plug-in pads for different transmission conditions, for example, the 89-type resistor.
- Straps or cross-connections required to make effective certain features which are subject to change by the operating personnel to meet the requirements of changes in circuit assignment or varying service conditions.
- Strapping of components to give certain filament voltage, tone intensity, transmission loss, percent break or pulse speed change in timing, compensation for trunk loop resistance change in gain of repeater, etc.
- Connection to transformer windings to convert from a high-to-low trunk impedance or vice versa.

Note: Option letters may be assigned to these variables on the schematic drawing in order to facilitate references in circuit notes, circuit descriptions, etc. When such variables are assigned option letters on the schematic drawing, they should be marked with suitable notes indicating their nature, for example: OFFICE WIRING LIST RECORDS NEED NOT BE MAINTAINED FOR THIS WIRING. When variables of a nonrecord nature are not assigned option letters, they may be covered by items in notes or charts on the schematic drawing.

Method-of Indication:

- When wiring only is optional, the option designation is directed with an arrow to each optional feed line.
- Components are considered optional if one or two or more differently coded pieces may be specified to perform a single circuit function on schematic features, requirements, etc. The method to be used in showing optional components on WDs is dependent on the method used in the schematic, the grouping of schematic figures on the WD figures, etc. The option designation is usually shown within the component symbol. For pigtail-mounted components, however, the option designations are shown on the outside. Component options are not shown on feed lines emerging from the optional component (see Figure 6-F-U, feed lines from

components 13 and 14). The component option is, however, shown on the feed lines representing the other ends of the connections, when connections at the other ends are optionally connected to a component which is either basic or of a different option (see Figure 6-F-U feed lines from component 12). If optional component codes are assigned on the schematic without identifying letters, assign options to the various codes and request the circuit designer to change the schematic to agree. If the Listing of all the codes at the component convention would cause congestion, show the codes and options in table form with a reference at the convention. For example:

Note: Pigtail apparatus mounted by means of wire terminals (pigtails) are designed as apparatus options, not apparatus and wiring options.

Figure 6-F-U Optional Components and Wiring

Conditional Wiring Symbols (OC, OL, AND LP):

- On WDs feed Lines are designated LP (loop) or OC (omit connection) to ensure circuit continuity when the associated component is not always furnished and OL (omit wire) to show omission of a wire when either of the two components is not always furnished. For an example of the use of these terms, see Figure 6-F-V. OC and OL are used only for surface wiring, whereas LP is used for local cable wiring.
- At times, variable wiring may be identified by notes which limit the scope or application of the wiring. The notes are shown by means of brackets or arrows at the affected feed line.

Figure 6-F-V Use of Designation OC, OL and LP

Note: Both surface wire and local cable runs are shown. Components 13, 14, and 15 if the option is furnished. If the option is not furnished, only components 12 and 14 are connected. The designation OC on the feed line from the component 13 indicates that if component 13 is not furnished, the run continues on to component 14. The designation OL on the feed line from component 14 indicates that if component 15 is not furnished, the wire is omitted. OL always indicates that what follows is optional. The local cable run connects 12, 13, and 14 if the option is furnished. If the option is not furnished, the run connects components 12 and 14. The designation LP on the feed line from component 13 indicates that the wire loops at component location 13 and continues on to component 14 if the option is not furnished.

Optional wiring that is to be provided but not connected is shown as local cable for circuits that include local cable and surface wire. Unconnected surface wiring cannot be provided. However, local cable wiring can be furnished in the cable form unconnected, but available for future use.

When a number of coded components are represented by a single symbol and listing of the codes at the symbol would cause crowding, the codes and options are tabulated on the same sheet and a reference to the table is indicated at the symbol (see Figure 6-F-W).

Figure 6-F-W Table of Component Codes and Options and Methods of Reference

16. Wiring, Wiring Methods, and Switchboard Cables

With the possible exception of cross connections, the gauge and code of all wires on a WD are specified. Generally, the major portion of the wiring can be covered by one or two manufacturing notes, for example, ALL WIRES INCLUDING WIRES IN SWITCHBOARD CABLE SHOULD BE (gauge and code) UNLESS OTHERWISE SPECIFIED. If possible, codes should be indicated whenever switchboard cables are specified. Show manufacturing notes to explain all wiring symbols, such as splice, cross-connection terminal, screw connection, etc. (see Bell Communications Research PUB a3351, Wiring Symbols, Wiring Abbreviations, and Definitions Wiring and Cabling, for symbols).

Generally, color, gauge, and code of cross-connection wire is not specified. However, one-conductor or multiple conductor wires are indicated as 1W, 2W, etc.

- Restrict the use of 1W cross-connection wire as far as possible and the splitting of cross-connection wires between rows of the same terminal strips and between terminal strips. To avoid congestion, assign not more than one cross-connection wire to each terminal.
- Show cross-connections at distributing frames in accordance with the number of wires in each set of jumpers.

For definitions of D method wiring and methods of running, see Bell Communications Research PUB 53351. This PUB also contains definitions of SW (Mfr Disc.) and SW1 surface wiring, method of running.

For assignment of colors, see Bell Communications Research PUB 53401, Color Combinations and Uses - Wiring and Cabling General Equipment Requirements.

In general, loose wiring is wiring that is not to be sewed into cable form but run loose and held into cable formation by fanning rings or other wiring devices when furnished (does not apply to wire run on cable racks). It will be necessary to designate all lead run as loose wiring with an LW symbol when run by the shop and to explain by a suitable manufacturing note similar to the following: LW DENOTES 24BW WIRE UNLESS OTHERWISE SPECIFIED, TO BE RUN LOOSE ON FRAME PE2 LWT-XXX~01 (or) ED-XXXXX-01.

Note: An LW symbol may also be used where it appears desirable for other reasons to identify the leads to be run as loose wire even though these leads may not be run by the shop.

For definitions and typical manufacturing notes of C type wiring, see Bell Communications Research PUB 53351, Wiring Symbols, Wiring Abbreviations and Definitions, Wiring and Cabling.

Variable wiring is wiring that is not constant, that is, the running and/or the connecting is dependent on the conditions controlling each application. These conditions may involve the selection of individual job requirements, such as, features and options or may involve manufacturing conditions only, such as, the circuit number of the position of the circuit in a sequence of like circuits, etc. WDs include complete information on the conditions controlling the running, and also on the conditions controlling the connecting of all VARIABLE wiring. WDs are prepared on the assumption that all VARIABLE wiring which is shown connected will be connected if that wiring and the associated apparatus are furnished unless restricted by limiting notes or options as described below.

- The running and connecting information for variable wiring is provided by option designations shown at each variable point of connection as specified. Such leads are run and connected as specified in the wiring lists.
- Limiting notes are shown at each termination for variable wiring not identified by optional designations explaining the conditions controlling the running and/or the connection of each variable lead. For example:

RUN ON ODD CKT ONLY.

RUN ON REGISTER NO. 4 ONLY.

RUN ON 1ST, 3RD, 5TH, ETC, TRUNKS.

OMR1 BETWEEN 5TH AND 6TH CKT.

RIJN BErWEEN 1ST AND 3RD, 3RD AND 5TH, 6TH AND 7TH, AND 7TH AND 9TH CKT.

CONNECT ONLY WHE~ FIG. 3 1~; SPECIFrF D.

Note: The circuit numbers used in all WD notes refer to the numbering shown on the associated manufacturing specification (unit numbering) rather than office numbering, unless otherwise specified.

- Specific notes covering the running of variable wiring are not required in cases where the lead colors are shown enclosed in parentheses and the running information is fixed at the other end of the lead by the controlling figure specified.
- Where wire and components are furnished for circuits or circuit features which may not be equipped initially, the general practice is to connect all wiring that is furnished to the components, such as j8C~S, lalllpS, terminal strips, sockets.

For general requirements on switchboard cables, see Bell Communications Research PUB 53401~ Color Combinations and Uses, Wiring and Cabling, General Requirements. Base the selection of switchboard cables on the information specified by the circuit designer's requirements for a particular equipment.

Show all leads which are required to be run only as switchboard cable enclosed within one or more cable symbols as needed to meet circuit design requirements. For example, transmit and receive leads sometimes should be run in separate cables, and leads requiring segregation should also be enclosed in separate cable symbols. Designate the individual leads as required to indicate pairs, triples, quads, etc. Designate the cable symbol to indicate gauge and wire code only when not covered by Manufacturing Note No. 1. The cable symbol may be designated with cable code when the number of leads is fixed and should be so designated when a specific cable code is a requirement. Figure 6-F-X indicates typical examples of the methods to designate feed lines (stubs) on WDs to indicate the following:

- Whether to be run as local cable, switchboard cable, or loose wire.
- The gauge, code, and (in some cases) the colors of the conductors

Note: Each sketch in Figure 6-F-X covers a specific case assuming the conditions covered by Note 1 in the Gauge Code Column on the drawing read as shown.

Whether wires are run in switchboard cable or as wire via cable racks depends on the number of wires involved. Five or more wires are run in switchboard cable, four or fewer are run loose on cable racks. If either condition exists because of a varying number of wires, the feed lines are shown enclosed in a cable symbol, and designated to indicate color (as required) gauge, and code. See Figure 6-F-~, Sketches 5, 6, 10, 11, and 12, and Figure 6-F-Y for examples.

Note: The practice of showing a cable symbol enclosing leads which are always run as wire is not applied to: (a) power wire, (b) IA fire detection wire, (c) 14-gauge emergency wire cable, (d) 20BH red emergency alarm wire.

Figure 6-F-X Typical Switchboard Cable Designations

Figure 6-F-Y Method of Indicating Wiring and Switchboard Cable

If wiring, depending on termination, is to be run as either switchboard cable or local cable, the feed lines are shown with color designations, enclosed in the cable symbol and designated as required to indicate gauge and color. A reference note: DISREGARD COLORS WHEN CABLE IS USED is also indicated (see Figure 6-F-X, Sketch 7, and Figure 6-F-Z).

Figure 6-F-Z Method of Indicating Alternative of Local Cable or Switchboard Cable

If wiring is to be run as loose wire (LW), within the same bay or as switchboard cable to other bays, the feed lines are shown with color designations, enclosed in the cable symbol and designated as required to indicate gauge and code. A reference note: DISREGARD COLORS WHEN CABLE IS USED is also indicated (see Figure 6-F-AA).

Figure 6-F-AA Method of Indicating Alternative of Loose Wire or Switchboard Cable

Twenty-gauge wire will normally be limited to:

- Battery and ground leads where fuse size is larger than 1-1/3A and where battery supply is common to more than one circuit.
- For specific leads where resistance restrictions require use of heavier gauge.

If wires at two or more brackets on the same or on different drawings are required to be run in a common switchboard cable, proceed as follows.

- Designate each cable symbol to indicate the association with other cable symbols which are to be run in a common cable. The following methods are typical:

PART OF CABLE SHOWN IN FIG. 3 PART OF CABLE SHOWN ON T-XXXXX-XX,
FIG. 1. INCLUDES THREE LEADS SHOWN ON T-XXXXX-XX, FIG. 6. SEE OTHER
BRACKETS.

- Use a common designation for two or more brackets and connect the symbols with a light line.

In order to prevent cabling congestion at the relay rack, avoid the concentration of equipment requiring large numbers of cables. This includes lamp relay, group busy lamp, transfer key, and other equipment employing multicontact relays.

Show the following engineering note on all WDs covering such equipment:

THIS CIRCUIT REQUIRES AN UNUSUALLY LARGE AMOUNT OF CABLED-G.
CONSULT WITH THE TELCO ENGINEER REGARDING DISTRIBUTION OF
EQUIPMENT OVER SEVERAL BAYS TO AVOID CABLE-G CONGESTION.

Wiring Methods - Indication:

- If all wiring is of one method, the base line is shown undesignated.
- Local cable base lines are not designated except where more than one type of local cable is used.
- If a considerable portion of the wiring is D method, surface, or loose wiring, a separate base line is provided and designated; for example, SW1 or LW etc.
- If only a few wires on a WD are D method, surface (SW1), loose wiring (LW), or local cable wiring, the applicable designation is placed directly on the feed lines, or arrows are directed from the designations to the feed lines.
- A suitable manufacturing note is shown to specify the type and method (except cable) of wiring.

In general, a single feed line is used to represent one or more connection to the same terminal regardless of whether more than one wiring method is used, such as local cable and surface wire.

17. Wire Colors

The colors of wire available for use in local cables, surface wiring, D method wiring, and wiring to be run by the installer are listed in Bell Communications Research PUB 53401, Color Combinations and Uses - Wiring and Cabling General Requirements. Care should be taken in the selection of colors to limit the possibilities of F stitches.

Colors are not shown for wires in switchboard cable nor for wires run via cable racks.

Colors are shown on the feed lines for all local cable wires and loose wires.

The color of surface and D method wiring, excluding battery and ground connections, is specified in a manufacturing note. Colors of battery and ground wires are shown on the individual feed lines.

For colors of surface wire and-D3 method wiring, see Bell Communications Research PUB 53401.

In general, colors are assigned as follows:

- A single or solid color is selected when possible for the tip, ground, or positive side of the circuit. Multiple colors are selected for the ring, battery, or negative side of the circuit. When using switchboard cable as a local cable, refer to Bell Communications Research PUB 53401 for color assignments.
- The same color is generally specified for two or more wires connected to the same terminal (the same run) unless the wires are optional.

Show parentheses enclosing the colors or leads of noncontrolling figures which are to be run only when the associated controlling figure is specified. Where lead colors are not shown on the controlling figure, the component location number enclosed in parentheses is shown on leads of the noncontrolling figures (see Figure 6-F-BB).

Figure 6-F-BB Bracket Method of Connection Between Figures

Note: Figure 6-F-BB shows the BRACKET method of connection between figures. The same method of indicating leads which are to be run only when the associated controlling figure is specified is used for the BASELINE method of connections.

18. Relay Rack Ground Connection

In the preparation of WDs for circuits having a specified equipment arrangement and requiring connection to relay rack ground, show one relay rack ground convention for

circuit or unit and show either strapping or loop leads as required to the other points in the circuits or unit requiring connection to this ground. The relay rack ground convention is shown connected to the ground point in the circuit that is physically closest to the No. 6 ground wire of the relay rack (see Figure 6-F-CC.)

Figure 6-F-CC Relay Rack (RR) Ground

In addition to the above, on circuits requiring less than a full mounting plate, a stub strap (common strap convention) is shown at the ground termination point. When the equipment for two or more different circuits is mounted on the same mounting plate, the extra ground conventions will be disregarded, and only one lead will be run to the No. 6 ground wire.

In the preparation of WDs for surface-wired units, relay rack ground leads may be No. 24 gauge wire colored black and connected to the component requiring ground nearest the No. 6 ground lead. The following are exceptions:

- Where the schematic specifies a larger gauge.
- Where more than one 1-1/3A fuse is called for per circuit or where one fuse greater than 1-1/3A is specified per circuit.

19. Lead Designations

WDs should use, when they are shown on the schematic, the same functional designations. When spare switchboard cable leads that run between terminal strips are assigned to terminal punching, the terminal punching number of the terminal strips at the controlling end will be assigned as the functional designation.

Cabling figures on schematics indicate the components to which leads are connected. While the component so indicated does not necessarily have to be that to which the lead is directly connected on the WD, it is preferred that this component be the one to which it is connected.

20. Installer Wiring

Installer wiring is designated either with the symbol, 0, or by a reference to a manufacturing note. Wires are shown as connected or unconnected by the shop according to whether field personnel shall reconnect or connect them.

The 0 symbol is used only to designate wires and straps RUN by the installers, and on those STRAPS on equipment normally wired by the shop which are to be run by the installer. It is NOT used to designate the following:

- Wires that are run by the shop and connected or reconnected by the installer.
- Noncontrolling ends of connections between controlling and noncontrolling figures.
- Wires in switchboard cable.
- Wires which are run FROM another figure.

Switchboard cable that is to be placed in position by the shop and run and connected at the other end by the installer shows a reference at the cable symbol to a suitable manufacturing note. The note is checked under both the SHOP and INSTALLER headings.

Installer-wired straps with variable connections are shown in accordance with the method specified in Figure 6-F-DD. Directions for wiring are given in a manufacturing note.

Figure 6-F-DD Method of Showing Straps with Variable Connections

On schematics, the current or voltage adjustment resistors of electron tube filament and heater circuits are shown unstrapped. The WDs omit the straps so that the equipment will be shipped with the resistors unstrapped. Show the installer-affected manufacturing note at the resistors similar to the following:

INSTALLER AJUSTS STRAPPING AT THE (A), (B), AND (C) RESISTORS,
COMPONENT LOCATIONS 16, 17, AND 18 AS REQUIRED DURING
INSTALLATION TEST.

Note: Do not include- in the manufacturing note the current or voltage requirements because the installer refers to the schematic when straps are placed.

Leads that are to be connected during tests are run and connected at one end by the shop and connected at the other end during installation tests by the shop or the installer. When requested by the responsible shop or installation test organization, designate leads AT which are run and connected at one end by the shop, the other end being left unconnected during wiring operations for connection by the shop or installer during their respective testing operations. Show the leads connected and explain with a manufacturing note similar to the following:

Note: It is understood that in the above illustrations the wires designated AT may require temporary connection by the shops for shop tests.

The following are typical manufacturing notes:

- NO WIRES ON THE DRAWING ARE TO BE RUN BY THE INSTALLER.
- NO WIRES ON THIS DRAWING ARE TO BE RUN BY THE INSTALLER EXCEPT LEADS IN CABLE.
- ALL WIRES ON THIS DRAWING ~N FIG. 2 ARE TO BE RUN BY THE INSTALLER.

Note: Do not include in the above notes covering leads to be RUN by the installer any reference to other notes covering leads to be connected or reconnected by the installer or to straps to be run by the installer.

All leads which are to be run by the shop and connected or reconnected by the installer are designated in the body of the drawing with a reference to a manufacturing note. Show the leads connected if they are to be connected by the shop and reconnected by the installer. Show the leads unconnected if they are to be left unconnected by the shop for connection by the installer. In case both conditions (connect and reconnect) occur in a drawing, show a separate note for each condition.

Include in the note a reference to the location of the affected wiring so that the wiring may be readily located without searching the drawing. The following manufacturing note is typical: LEAD IS LEFT LONG ENOUGH TO REACH ANY TERMINAL ON (A) TRANSFORMER AT APPARATUS POSITION 5. TO BE CONNECTED BY INSTALLER PER TELCO INFORMATION.

If the strap is variable, complete information as to the requirements controlling the furnishing of the strap and the terminations should be furnished. This information may be shown at the strap convention in the body of the WD, or it may be shown as a manufacturing note (installer affected) with a reference to this note at the strap convention (Figure 6-F-DD). When the strap is not variable, no additional information on the running and connecting is required other than the 0 symbol when necessary. Whether the strap is shown connected at both ends, or all possible connections are indicated schematically, will depend on individual conditions. In general, the strap should be shown connected if it is so shown on the schematic or if it is identified by an option.

21. Battery and Ground Connections

The circuit drawings show to which terminals of components the battery and ground wires run. With certain components, however, the circuit drawing will not show to which terminals the wires are connected. The following table, Battery and Ground Connections, shows to which terminals of a component, mounted and viewed from the wiring side, battery and ground wires, when required, are connected.

Battery and Ground Connections

22. Live Leads - General

Insulation is specified for the ends of all unconnected live leads. Common ground connections are excepted. The skimmers of all unconnected LIVE leads in equipped and unequipped circuits are protected individually. All leads except common ground leads which are or may be connected at one end to any part of a circuit which is equipped for service are considered as LIVE leads. The sleeving requirement is shown on the WD by either of two methods.

- Designate each LIVE lead with the letter "L" enclosed in a circle and explain the significance of the L symbol with a manufacturing note similar to the following:

L DENOTES LIVE LEADS TO BE INSULATED, WHEN NOT CONNECTED, AS FOLLOWS:

Fig.	APP	LEAD
1	(F) REL	R-BL
2	(L) REL	1 OR 2 R-BK-BL

**** **DANGER:** ****List all leads which could become LIVE under any possible application of the various figures and options, that is, if certain optional components were omitted, if certain figures or circuits were equipped initial, or were wholly or partially equipped on additions, etc.

- Show a manufacturing note reading as follows:

INSULATE ALL UNCONNECTED LEADS

This method is used on critical circuits where it is more economical to insulate all unconnected leads rather than determine and insulate the individual LIVE leads. This method is applied to other equipment as required.

No. 5 Crossbar - All equipment

No. 1 Crossbar - All common control equipment such as markers, senders, link controllers, and marker connectors

No. 4 Crossbar - All equipment except trunk units.

- The arrangement of circuits and the manner of running leads in the local cable are such as to avoid (as far as practicable) the necessity of insulating LIVE leads. This may be accomplished by arranging the leads so that those with potential will loop (do not cut) through the location of variable or unequipped components.

When possible, leads are looped rather than terminated at unequipped positions in order to reduce the number of unconnected wires requiring insulation.

23. Pairing Designation (P)

All the pairs on a WD, including split pairs, are designated P (see Figure 6-F-EE).

Figure 6-F-EE Method of Indicating a Pair

Pairing is the practice of twisting two or more individual conductors of a circuit together to minimize electrical interference. In general, PAIRED leads are of the same

length and maintain the specified twist throughout their length. Indicate PARING on WDs when specified in design requirements by means of the following:

When a specific twist is required, use the following symbols:

- P1 or T1: Pair or triple made by twisting two or three single wires (respectively) together with not less than one turn (as required) per inch.
- Q1: Quads made from two (P1) pairs twisted together with approximately one turn in each 3 inches with each pair made by twisting two single wires together with approximately one turn per (as required) inch.

In all cases, show pairing designations in the body of the drawing for leads to be run in switchboard cable or as miscellaneous wiring by the installer. On simplified airline drawings, show pairing designations for leads in local cable in the body of the drawing unless this practice would cause congestion in which case show the pairing information in a table on the drawing. Do not use both methods for local cable wiring on the same drawing. In general show:

- Pairs for:
 - Tip and ring talking conductors.
 - Tip and ring signaling conductors when connected directly across the line.
 - Tip and ring audible ringing leads (single or party ringing).
 - Individual tip and ring battery leads from ground and battery bus bars.
 - Ground and alternating ringing leads and loops (excluding ringing mains).
 - Ground and battery to howler, bell, buzzer, and similar circuits.
- Triples for:
 - Ringing leads and loops (excluding ringing mains).
 - Leads in operators' telephone circuits where one tip and two ring leads are required (or vice versa).
 - Leads carrying tone or high voltage.

Miscellaneous signal leads.

- Quads for:

Talking conductors on the line side of phantom group repeating coils where a phantom circuit is desired from two physical or side circuits.

Leads bridged to talking conductors on the line side of phantom repeating coils as leads to composite sets on combined telephone and telegraph lines or drainage coil taps in carrier circuits.

Superimposed ringing leads employing AC current with a positive and negative bias (except ringing mains).

- Twist for:

Harmonic ringing leads.

The number of circuits served by a common wire is indicated by a note at the wire involved as follows:

ONE PER FIGURE 1

ONE PER PANEL

ONE PER POSITION

ONE PER STRIP

ONE PER 5 FIGURE 1

When odd and even circuits are looped, the common wire LS designated as follows:

ONE PER 5 ODD FIG. 1; 1ST, 3RD, ETC.

RUN ON EVEN CIRCUITS ONLY

ONE PER 5 EVEN FIG. 1, 2ND, 4TH, ETC.

The following table of most commonly used gauges of wire shows the maximum number of soldered and solderless connections that may be made to a terminal.

In general, the number of wires connected through the holes of a component terminal is limited to three. Wires of 20 gauge or larger should be limited to two although three are permitted where necessary.

Note: The practice of connecting three 22-gauge wires or three 20-gauge wires to a component terminal is limited to cases where the doubling up of wiring on other terminals is impractical.

The maximum number of wires connected to terminals of step-by-step switch-type units is restricted as shown in the following table entitled 24-Gauge Wires on Step-by-Step Switch-Type Circuits.

Not more than three straps are connected to the shank of a component terminal in addition to the wires connected through the hole of the terminal.

Not more than four 16-gauge leads are run through a terminal strip fanning hole.

The method of terminating shielded pairs provides for the splicing of the ground leads of pairs from the same stitch. In order to avoid unsightly cable forms, not more than two shield grounds may be spliced together. Use loops for connecting the shield grounds of pairs from the same or other stitches. The lead which connects to the ground is designated GT.

Solderless wrapped connections are made only on terminals specifically designed for that purpose. Since the number of connections which may be placed on a terminal by the wrapping tool is limited to two 22 or 24 gauge leads, the connections to such terminals should be limited to that number in-so-far as practicable. If, however, the connection to a single terminal or more than two 22-gauge or 24-gauge leads or the connection of larger gauge leads cannot be avoided, the additional leads may be connected although it will necessitate hand-wrapping and soldering.

24. Straps

For definitions of the terms strap, common strap, individual strap, and sleeved strap, see Bell Communications Research PUB 53351, Wiring Symbols, Wiring Abbreviations, and Definitions - Wiring and Cabling.

Straps are shown as direct connections running from terminal to terminal (not to a base line) and are not designated "bare" See Figure 6-F-DD for the method of showing a strap with variable connections. Directions for variable strapping are shown at the straps or in a manufacturing note.

24-Gauge Wires on Step-By-Step Switch-Type Circuits

Note 1: A maximum of two wires may be connected to each terminal of vertical off-normal, rotary off-normal, 10th or 11th rotary step, vertical internal, or rotary internal springs consisting of three or less terminals.

Note 2: The connection of three wires to a switch plug terminal is undesirable and should be avoided. Three wires may be connected to a switch plug terminal, but only where doubling up of wiring on other terminals is impracticable.

Note 3: The maximum number of wires which may be connected to a terminal, as restricted above, may be waived only where the circuit condition dictates.

The term strap is applied to a form of direct wiring used for connecting component terminals where the use of local cable or other forms of wiring would be cumbersome or cause congestion. They are used for extending common connections such as battery, ground tone, etc., or to make repetitive or other types of connections on the same or through closely associated similar components. Strap leads are run as BARE wire, J, BW, BH, BG, or BRC wire depending on length, clearance, voltage and current except on equipment that is completely surface-wired. On equipment that is completely surface-wired (SW1 or D3), straps are used only for connections that can be and normally are made with BARE wire.

The schematic often shows a strap symbol to indicate a multiple connection without any supplementary information. Such connections are run as STRAPS or LOOPS in accordance with the following instructions.

Show straps for connecting terminals in the following cases:

- On the same component.
- On different pieces of adjacent or closely associated components on the same mounting plate or strip.

Straps ARE NOT used in cases where they:

- Prevent proper access to the wiring terminal or other parts of the component.
- Interfere with the operation of the component.
- Interfere with the removal of components for maintenance or inspection purposes.
- Obscure the designations.

Show LOOPS for making connections as shown in the following table entitled Exceptions to the General Rules for Strapping.

Specific strapping practices are as follows:

- L designation straps for cord circuit lamp sockets: If battery or ground lead is common to more than one cord circuit, connect battery or ground lead serving both front and rear lamps to left terminal of rear lamp socket and left terminal of front lamp socket on first equipped circuit. Strap left terminals of all rear lamp sockets together. If battery or ground lead is not common to more than one cord circuit, connect battery or ground lead serving both front and rear lamps to left terminal of front lamp socket.
- SS designation straps on distributing frame terminal strips:

Ordinarily, straps should be shown on the switchboard cable side on the opposite side from the jumpers.

Where straps are placed temporarily or arranged for conversion, designate such straps SS (Surface Strapping). These straps are added by the installer when solderless wrap-type terminal strips are used.

- Straps on relay rack unit and panel terminal strips should be shown on the switchboard cable or bay local cable side.

Exceptions to the General Rules for Strapping

- Straps on relay rack bay terminal strips should be shown on the switchboard cable side.
- Observe the following precautions insofar as possible in showing straps on keys:
Keep strapping on one side of the key with a minimum amount of strapping between the right and left sides of the key.
Keep strapping on the upper terminals.
- Straps on selector switches: Strap adjacent terminals vertically, horizontally, or diagonally; also strap terminals vertically skipping one or two terminals as required.
- Straps on crossbar switches: Strap any terminals in a vertical and horizontal group, also any terminals on adjacent horizontal groups but not diagonally in such a manner that two straps would cross.
- Strap the fuse alarm lamps of vertically adjacent panels together with a sleeved strap instead of a looped lead in the cable form.

25. Loops

A loop is a colored local cable wire used for the same purpose as straps in cases where the location of the terminals voltages, or some wiring condition such as congestion, precludes the use of straps.

Show loops to connect terminals as follows:

- Of leads carrying over 48V.
- On components located on different mounting plates or straps.
- Where straps would interfere with the placing of other wiring, such as, jumpers or switchboard cable.
- Where straps would cause congestion as indicated in paragraphs 24.08 through 25.02 of this Part.

Loops on terminal strips (all types):

- Show loops to be run by the shop on the local cable side on relay rack units, bays, or panels.
- Loops that are to be run by the installer between units, bays, or panels, or when five or less leads are required between terminal strips on the same relay rack unit or bay, are shown on the switchboard cable side on the opposite side from the local cable.

- When six or more leads are to be run between terminal strips on the same unit or bay, they are shown on the local cable side to be run by the shop.
- If a circuit requires strapped rows of terminals which may be split over two adjacent terminal strips, the WD should be arranged to show straps between rows on the same terminal strip and colored 20 AM or 20 BH loops between rows on adjacent terminal strips.

Note: In cases where the circuits are likely to be ordered in quantity, consideration should be given to the use of combinations of single, pairs, triples, and quads for the interblock multiple in order to facilitate installation.

Except for panel dial system circuits where multiple strapping is involved, designate all local cable leads which are to be looped at component positions, when that component is not always furnished as LP. Explain with a manufacturing note similar to the following: LP WIRES TO BE LOOPED AND NOT CUT WHEN OPTIONAL COMPONENT IS NOT SPECIFIED. When looped leads can be grouped with other leads at the position of wired only components, show a bracket and a note similar to the following: LOOP AT POSITION OF (component). When optional components are not furnished and wires are required to be spliced at a component position, the following manufacturing note is used. LP1 WIRES SHOULD BE SPLICED AND LOOPED WHEN OPTIONAL WIRING OR COMPONENT IS NOT FURNISHED.

A hairpin loop is shown by feed lines to the base line. The wire color of the loop is different from the color of the run of which it is a part, and the F stitch designation is used inasmuch as the regular stitch serves to hold the loop. See Figure 6-F-FF for a typical example.

Figure 6-F-FF Method of Showing Hairpin Loops

Unless otherwise specified, hairpin loops are shown on the following:

- Terminals of a sequence switch wired from the same stitch in the cable form.

- Terminals in a horizontal row of selector banks.
- Terminals of the same key unit in Toll Systems circuits when required, and on terminals of keys and jacks in Telegraph Systems.

26. Miscellaneous

Skinner: For definitions of skinner, slanting skinner, straight skinner, and skinner length, see Bell Communications Research PUB 53351, Wiring Symbols, Wiring Abbreviations, and Definition - Wiring and Cabling. An extended skinner connection is made by extending the bare portion of a skinner termination on a terminal to an adjacent terminal on the next terminal in line in order to avoid the use of a strap or loop (used with soldered connections only).

Shank Connection: The term "shank connection" is applied to a connection which is established by connecting a lead near the base of a terminal. Shank connections must be made where the hole, hook, or notch of the terminal will not accommodate all of the leads which must be connected or any individual lead because of its size, or where the hole, hook, or notch must be left free for other wiring to be connected as a subsequent operation. Shank connections are not required at the end of shop-placed strapping where the subsequent wiring to be placed at the terminal consists only of straps.

SH Designation: Designate all wiring connected to the shank of terminals as SH on WDs, except for straps. When the WD sheet indicates a surface wire and local cable lead connected to the same terminal, the SH designation need not be shown on the WD. In such cases the shank connection indication is shown on the surface wiring lead on the SWJ, D3J, or similar-type drawing when this information is required by the shop.

Solderless Wrapped Terminals: Leads connected to components arranged for solderless wrapped connections should not be designated SH. The first connection to a solderless wrapped terminal should be made so as to provide for a second connection.

Lamps, Lamp Caps, and Lamp Sockets: Show codes of lamps in all cases, omitting the voltage and current rating. Show codes of lamp sockets, and lamp caps except where the component is variable, in which case omit reference to the lamp sockets and lamp caps.

Protectors or Connectors: Show distributing frame protectors or connectors only when terminating inside of central office leads on the protectors or connectors.

Bus Bars, Fuses, Batteries, Etc. - Designation: Voltages shown on WDs are the rated voltages, such as 24V, 48V, etc., rather than the minimum and maximum voltages, such as 22-26V, 45-50V, etc., u~ y shown on schematics. Indicate supply, such as SIGNAL, CONTINUOUS RINGING, TALK, etc. Designate ground bars to show types, such as SIGNAL, TALK, etc. Do not designate the polarity of -48V, -24V, or ~130V battery. However, when the +130V battery supply is used with a supply of the same potential

but of opposite polarity, the polarity of both is designated. All other battery supplies are designated with polarity and potential.

Equipment Location Sketch: This sketch provides a ready reference to indicate the mounting plates or the portion of mounting plates of units or bays with which each B sheet of the WD is associated. The sketch is normally only added on WDs associated with large units or with bays, frames, etc.

Connectors Equipped with Printed Wiring Assemblies: The unit WD is used to record all printed wiring assemblies associated with the unit specification. Each assembly code is identified next to the connector into which it plugs. The following illustrates a few methods used to record these assemblies.

- Connectors J1, J2, and J3 would indicate the equipment code of the plug-in assembly terminated at that position, for example:
J1 E/W ED-54321-30 G1
J2 E/W ED-54322-30 G1
J3 E/W ED 54323-30 G1
- Minor changes that do not affect products' interchangeability would be identified by means of a LINE-OUT and the addition of a lettered list or group to identify the change. The LINE-OUT is used to indicate that G1 has been provided and G1, A is the current interchangeable production model, for example:
J2 E/W ED-54322-30 G1, G1, A
- New features or optional assemblies would be introduced and **identified by** means of a circuit option on the unit WD, for example:
J1 E/W ED-54321-30 G1 X
J1E/W ED-54321-30 G2 Y
or
J1 E/W ED-54321-30 G1 X
J1 E/W ED-54330-30 G1 Y

The methods used to record apparatus-coded printed wiring assemblies will be the same as described above except that no record will be kept on the vintage of apparatus-coded printed wiring assemblies.

Brackets on Wiring Diagrams: In general, brackets will indicate information which is for record only, such as when a wire color is changed, the original color will be enclosed in brackets.

Parentheses on Wiring Diagrams:

- Parentheses are used for enclosing:

Functional component designation (Systems WDs)

Colors or component location numbers on leads which are to be run only when the associated controlling figure is specified.

SD and T drawings cross-reference table information shown FOR INFORMATION ONLY.

modifying clauses in notes, figure subtitles, etc., when such treatment is considered preferable to use of commas or semicolons and is not likely to be confused with functional designations.

Since parentheses indicate functional designations, they cannot be used on WDs to enclose letters, abbreviations, numbers, etc., that are not functional designations but might be mistaken for functional designations if so enclosed as for example, circuit numbers or terminal or component designations shown for wiring information only. Neither can they be used to differentiate between function designations that are not to be stamped. WDs are not used to furnish stamping information.

1. Wiring Diagram Manufacturing Notes





1.1 General

This appendix covers a listing of typical manufacturing notes used on wiring diagrams.

The note numbers listed herein are for reference purposes only and should not be used as the note number on the wiring diagram.

2. Typical Notes-Listing



The following is a listing of typical notes used on wiring diagrams:







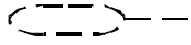

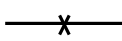
-   Record optional component or wiring.
-   Nonrecord optional component or wiring.
- J - End of key nearer hinge viewed from terminal side.
- J - (Top) (Right) end of key viewed from terminal side (keyshelf open).
- J - (Top or left) (Top or right) side of key viewed from terminal side.
- "B" - Terminal nearest base of terminals strip. (Right or bottom terminal for terminal strips that have two fanning strips.)
- B1- Terminal nearest mounting plate or panel.
- B2 - Lug nearest base of terminal strip.
- E - Adjacent rows (perpendicular to the fanning strip) of terminals.
- K - Top or left row (perpendicular to the fanning strip) of terminals.
- K1 - Top of left terminal on 203- and 700A-type terminal strips.
- K2 - Top left terminal on 224-type terminal strip looking at local cable side of strip.
- K3 - Bottom left terminal on 224-type terminal strip looking at local cable side of strip.
- K4 - Right-hand terminal lug looking at rear of terminal strip.
- LL - Terminals of adjacent components should be soldered together.
- DU - Connection made to surplus terminal.
- All wires (including wires in switchboard cable) should be (gauge and code) [except on moistureproof jobs where they should be (gauge and code) unless otherwise specified.]
- U - 22P shielded wire.

- U1, U2, U3 (gauge and code) (code) (shielded wire) (cable) Designations U1, U2, or U3 should be changed to U when used individually.
- In all cases when shielded wire shown in Note 16 is used, assign U designation to this wire and U1, U2, or U3 to the other types of shielded wire used on the same drawing.
- CU - (code) Coaxial cable.
- EU - (Gauge and code) (code) (shielded wire) (cable).
- EU1 - (Gauge and code) shielded wire in (750, 751, 752, 753, 755, 756, or 757 type cable).
- RU - (code) twin-conductor, shielded office cable.
- FTL (code) flat twin lead (rating) conductor.
- TTL (code) tubular twin lead (rating) conductor.
- Leads shown terminated in components without terminals are furnished with components.
- PT - Leads furnished with component.
- PTa - Pigtail leads
[Less than 3/8 inch but not less than (dimension) inch long.]
[(dimension) + (dimension) inch long.]
(with lengths as indicated.)
(Run in paths shown) [in Figure (designation)]
(Run with lengths and paths as shown)
- PTa1, PTa2, etc - When two or more special treatments of pigtail leads (see PTa) are required on the same drawing, numerical suffixes identify the 2nd, 3rd, etc., treatments specified on the drawing.
- Run on odd circuits only.
- Run on register No. 4 only.
- Run on 1st, 3rd, 5th, etc. trunks.
- Omit between 5th and 6th circuit.
- Run between 1st and 3rd, 3rd and 5th, 6th and 7th, and 7th and 9th circuits.
- Connect only when Figure 3 is specified.
- (F) (F1) (F2) - Separate stitch from cable form.
- GT - Ground wire.
- .P- Pair.

- Triple.
- P1 or T1 - Pair or triple made by twisting 2 or 3 single wires respectively together with not less than one turn per (as required) inch.
- Q - Quad.
- Q1 - Quads made from two (P1) pairs twisted together with approximately one turn in each three inches, with each pair made by twisting two single wires together with approximately one turn per (as required) inch.
- SS - Surface Strapping.
- L - Strap should be placed on first equipped circuit of group only.
- SKR - Skinner connection.
- SH - Shank connection.
- (L) Denotes live leads to be insulated when not connected as follows.
- Insulate all unconnected wires.
- When this circuit is used on a moisture-proof job, these leads are 22BW.
- When this circuit is used on a moisture-proof job, all 22C wire is 22BW.
- Soldered and sleeved lead on the terminal to be sleeved with black sleeving per KS-7851.
- LP wires to be looped and not cut when optional wiring or component is not furnished.
- LPI - Wires should be spliced and looped when optional wiring or component is not furnished.
- OL - Omit lead unless connections for both ends are provided.
- OC - Omit connection and consider as a continuous lead when associated component is not furnished.
- (a) (a1) (a2) - (gauge & code) wires [colored (color)] which should be segregated from all other wires)
[(dimension) \pm (dimension) inch long].
(run in paths shown) [in Figure (designation)]
[the length indicated \pm (dimension) inch and run in paths shown] [in Figure (designation)].
- No wires on this drawing are to be run by the installer.
- No wires on this drawing are to be run by the installer except leads in cable.
- All wires (on this drawing) (in Figure ____) are to be run by the installer.

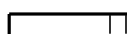
- ϕ wires (in Figure) (at Component Position) to be run by the installer.
- Wires should be long enough to reach any terminal on (component **identification**) at (component position) and should be (connected) (reconnected) by installer per job specifications.
- Shop to extend wire 8" past right end of mounting plate, looking at rear for connection to No. 6 bay ground wire as follows:
 - By the shop when unit is shop-mounted.
 - By the installer when unit is field-mounted.
- Lead is left long enough to reach any terminal on (A) transformer at Apparatus Position 5 to be connected by installer per telephone company information.
- Straps at (component identification) should be (added) (cut) by the installer to obtain the proper (capacitance) (resistance).
- Straps at (component identification) should be (added) (cut) by the installer.
- Strap connections in accordance with manufacturing requirements.
- AT - Wires at (component identification) should not be connected until shop tests are completed.
- AT1 - Wires at (component identification) should be connected by the installer during relay and installation tests.
- ATR - [wire (S)] at (component identification) should not be connected until relay tests are completed.
- _____(D,DI) wiring to be (gauge & code) colored unless otherwise specified.
- D2 - Wiring to be (gauge & code) colored unless otherwise specified run and dressed in paths and locations within 1/8" of those shown on (include complete information as to paths or any other peculiarity in each case).
- D3 - Wiring is (gauge & code) [colored (color)] (unless otherwise specified) (and) run in general paths shown [in Figure (designation)] (on ED--) (J--).
- SW1 - Surface wiring is 24 (BG) (BW) colored green unless otherwise specified.
- All wiring to be SW1, surface wiring 24 (BG) (BW) colored green unless otherwise specified.
- All wiring to be (D, DI, D2, D3) surface wiring (gauge & code) colored unless otherwise specified.
- Leads to be skinned to length for connection by installer.

- C-Wiring carrying low-intensity noise voltages. No special manufacturing or installing practices involved.
- C-Wiring caying low-intensity noise voUages. Segregation is required when run in sewed local power cable.
- C1-Wiring to be run in separate cable inside local cable to facilitate hinge motion.
- C2-Wiring carrying high-intensity noise voltages should be segregated from all other wiring except identical "C2" wiring when run in (sewed local power cable) formed ends of switchboard cable, or local cable.
- CA-Wiring caying commercial power within a unit should be segregated from all other wiring except other "CA" wiring when run in local cable.
- C5-Wiring carrying medium intensity noise voltage should be segregated from all other wiring except "C" and other "C5" wiring when run in sewed local power cable, formed ends of switchboard cable, and local cable.
- LW denotes 24BW wire unless otherwise specified, to be run loose on frame per (LWT-00000-11) (or ED-00000-01).
- (1W) (2W) (3W) (4W) - (one) (two) (three) (four) conductor cross-connection wire.
- 4W (P) - Four conductor, multiple twin, cross-connection wire.
- Information in brackets t ~ is for record only.
- When Figures (A) or (B) are used with universal wiring Figure (C), insulating information for Figure (C), should be used. [When Figures (A) or (B) etc., should be used].
- All pigtail components in Figure (designation) should be positioned as shown.
- All pigtail components in Figure (designation) should be positioned as shown and should be kept l(dim) inch] away from metal surfaces.
- All (wires including) PTa leads tin Figure (designation)] should be run (in paths shown) (with lengths and paths shown) (as short as practicable) (waiving minimum length requirements when necessary.)
-  Shield connection (with ground tracer).
-  Shield connection (without ground tracer).
-  Shield connection to apparatus cover.
-  Splice.

-  — — · Coaxial shield connection.
-  — — ⊗ Coaxial shield connection.
-  — — — — Division of general wiring views.
-  — — — — Thru intermediate appearances.
-  Ground or foil end (for capacitors only).
-  Screw connection or binding post.
-  Leads not included in local cable, but to be run by shop.
-  Cable.
-  — — — — Connection furnished as part of apparatus.