

Qwest Corporation Technical Publication

Interconnection and Collocation for Transport and Switched Unbundled Network Elements and Finished Services

Copyright 1996, 1997, 1999, 2000, 2001,
2002, 2003, 2004, 2006, 2007, 2011©
QWEST Communications International Inc.
All Rights Reserved

77386

Issue N
February 2011

NOTICE

This publication provides technical information about Interconnection and Collocation with Qwest for Private Line Transport and Switched services as well as any Unbundled Network Elements (UNEs) sold by Qwest. Also included are descriptions of Physical, Virtual, Shared Physical, Cageless Physical and InterConnection Distribution Frame Collocation. Generalized descriptions and examples of Network Channel and Network Channel Interface codes are also included. The Interconnector will need to use this information when collocating in Qwest wire centers and connecting to Qwest transport and switched services or UNEs. These include, for example, DS3 Service, DS1 Service, Analog Private Line Transport Service, Digital Data Service, Frame Relay Service and various similar UNEs

Qwest Corporation reserves the right to revise this document for any reason, including but not limited to, conformity with standards promulgated by various governmental or regulatory agencies; utilization of advances in the state of the technical arts; or to reflect changes in the design of equipment, techniques, or procedures described or referred to herein.

Liability to anyone arising out of use or reliance upon any information set forth herein is expressly disclaimed, and no representation or warranties, expressed or implied, are made with respect to the accuracy or utility of any information set forth herein.

This document is not to be construed as a suggestion to any manufacturer to modify or change any of its products, nor does this publication represent any commitment by Qwest Corporation to purchase any specific products. Further, conformance to this publication does not constitute a guarantee of a given supplier's equipment and/or its associated documentation.

Ordering information for Qwest Publications can be obtained from the Reference Section of this document.

If further information is required, please contact:

Qwest Corporation
Manager – New Services Planning
700 W. Mineral Ave. IA E12.18
Littleton, CO 80120
E-mail: techpub@qwest.com

COMMENTS on PUB 77386

PLEASE SEND YOUR COMMENTS/SUGGESTIONS TO:

Qwest Corporation
Manager - New Services Planning
700 W. Mineral Ave. IA E12.18
Littleton, CO 80120
E-mail: techpub@qwest.com

Information from you helps us to improve our Publications. Please take a few moments to answer the following questions and send to the above address.

Was this Publication valuable to you in understanding the technical parameters of our service? YES _____ NO _____

Was the information accurate and up-to-date? YES _____ NO _____

Was the information easily understood? YES _____ NO _____

Were the contents logically sequenced? YES _____ NO _____

Were the tables and figures understandable and helpful? YES _____ NO _____

Were the pages legible? YES _____ NO _____

If you answered NO to any of the questions and/or if you have any other comments or suggestions, please explain:

(Attach additional sheet, if necessary)

Name _____ Date _____

Company _____

Address _____

Telephone Number _____

E-Mail _____

CONTENTS

Chapter and Section	Page
1. Introduction	1-1
1.1 General.....	1-1
1.2 Reason for Reissue	1-1
1.3 Purpose and Service Availability	1-1
1.4 Scope	1-2
1.5 Terminology.....	1-2
1.5.1 Interconnectors.....	1-2
1.5.2 Interconnector Designated Equipment.....	1-2
1.5.3 Tariffs, Catalogs and Contracts.....	1-2
1.5.4 Competitive Local Exchange Carrier, Co-Provider	1-2
1.5.5 Unbundled Network Element (UNE)	1-3
1.5.6 Finished Service.....	1-3
1.5.7 Expanded Interconnection Channel Termination.....	1-3
1.5.8 NIs, POTs and POIs	1-3
1.6 General Requirements.....	1-5
1.7 Non-Access Private Line Services	1-5
1.8 Responsibilities.....	1-6
1.9 General Information Source	1-6
1.10 Document Organization.....	1-6

2.	Introduction to Collocation and Interconnection	2-1
2.1	General Concept.....	2-1
2.2	Collocation	2-1
2.3	Unbundled Network Elements (UNEs).....	2-2
2.4	Finished Services.....	2-2
2.5	Network Interfaces	2-2
	2.5.1 Network Interfaces for UNEs.....	2-2
	2.5.2 Network Interfaces for Finished Services.....	2-2
2.6	Interconnection Arrangements	2-3
2.7	Transport Access to the Qwest Wire Center	2-3
	2.7.1 Collocation Point of Interconnection (CPOI)	2-4
	2.7.2 Standard Fiber Entrance Facilities and Related Topics	2-4
	2.7.3 Non-Standard Metallic Pair Entrance Facilities.....	2-9
	2.7.4 Non-Standard Coaxial Entrance Facilities.....	2-10
	2.7.5 Non-Standard Microwave Entrance Facilities	2-10
	2.7.6 Finished Services Instead of Entrance Facilities	2-11
2.8	Facility Connected (FC) Collocation	2-12
	2.8.1 FC Collocation Copper Facilities	2-12
	2.8.1.2 DS0 FC Collocation	2-15
	2.8.1.2 DS1 FC Collocation.....	2-15
	2.8.1.3 DS1 FC Collocation.....	2-15
	2.8.2 Fiber Entrance Facility for FC Collocation	2-17
	2.8.3 Non-Standard FC Collocation Entrance Facility	2-17
2.9	Equipment and Wiring Requirements.....	2-18

CONTENTS (Continued)

Chapter and Section	Page
3. Interconnection Arrangements	3-1
3.1 Typical Wire Center Arrangement	3-1
3.2 Interconnection Arrangements	3-4
3.2.1 Basic Requirements for Interconnection	3-4
3.2.2 DS0 or Voice Level Needs	3-6
3.2.3 DS1 Level Needs	3-7
3.2.4 DS3 Level Needs	3-8
3.2.5 Fiber or Optical Level Needs	3-8
3.3 InterConnection Distribution Frame (ICDF) Frame	3-9
3.3.1 General Description	3-9
3.3.2 DS0/Voice ICDF	3-10
3.3.3 DS1 and DS3 ICDFs	3-13
3.3.4 Fiber ICDF	3-15
3.3.5 Usage	3-16
3.4 Network Interface Options	3-17
3.4.1 Standard ICDF Arrangement	3-18
3.4.2 Direct Connection - Point of Termination Arrangement	3-20
3.4.3 Combinations of Arrangements	3-24
3.5 Tie Cables, Frames and Terminations	3-24
3.5.1 General Requirements	3-24
3.5.2 ICDF Arrangement	3-27
3.5.3 Direct Connection - POT Arrangement; Qwest Supplied	3-28
3.5.4 Direct Connection - POT Arrangement; CLEC Supplied	3-28
3.6 Combination of UNEs on Different "Design-To" Frames	3-29
3.7 Comparison of Interconnection Arrangements	3-29
3.9 Direct Connection Between Entrance Facilities and UNEs	3-32

5.	Responsibilities.....	5-1
5.1	Basic Responsibilities.....	5-1
5.2	“Design-To” Point.....	5-1
5.3	Design Responsibilities -- Digital Unbundled Elements.....	5-3
5.4	Design Responsibilities -- Analog Unbundled Elements.....	5-4
5.5	Design Responsibilities -- Optical Unbundled Elements.....	5-4
5.6	Design Responsibilities with Finished Services	5-4
5.7	Design Responsibilities without Collocated Equipment.....	5-4
5.8	Record Keeping and Forecasting Requirements	5-5
5.9	Basic Configurations for Multiple Equipment Locations.....	5-5
5.10	Test Access for Equipment and Tie Cables	5-6

CONTENTS (Continued)

Chapter and Section	Page
6. Network Channel and Network Channel Interface Codes -- General	6-1
6.1 Network Channel (NC) Codes	6-1
6.2 Network Channel Interface (NCI) Codes	6-2
6.2.1 NCI Format	6-2
6.2.2 Example	6-4
6.3 Summary	6-4
6.4 NC and NCI Codes for Jumpers	6-4
7. DS3 Interconnection.....	7-1
7.1 Connections to Unbundled Network Elements or Finished Services	7-1
7.1.1 Finished Services	7-1
7.1.2 Unbundled Network Elements (UNEs).....	7-1
7.2 DS3 "Design-To" Point.....	7-2
7.3 DS3 Terminations and Tie Cables.....	7-2
7.4 Network Channel & Network Channel Interface Codes	7-2
8. DS1 Interconnection.....	8-1
8.1 Connections to Unbundled Network Elements or Finished Services	8-1
8.1.1 Finished Services	8-1
8.1.2 Unbundled Network Elements (UNEs).....	8-1
8.2 DS1 "Design-To" Point.....	8-2
8.3 DS1 Terminations and Tie Cables.....	8-2
8.4 Network Channel & Network Channel Interface Codes	8-2
9. Analog Interconnection.....	9-1
9.1 Connections to Unbundled Network Elements or Finished Services	9-1
9.1.1 Finished Services	9-1
9.1.2 Unbundled Network Elements (UNE)	9-2
9.2 Analog Voice "Design-To" Point.....	9-2
9.3 DS0/Voice Terminations and Tie Cables	9-2
9.4 Network Channel & Network Channel Interface Codes	9-2
9.4.1 Network Interface NCI Codes.....	9-2
9.4.2 Commonly Used Network Channel Codes.....	9-3
9.5 Non-Access Services	9-5
9.6 Circuit Design.....	9-5

CONTENTS (Continued)

Chapter and Section	Page
10. Interconnection at DS0 Digital Level	10-1
10.1 Connections to Unbundled Network Elements or Finished Services	10-1
10.1.1 Finished Services	10-1
10.1.2 Unbundled Network Elements (UNEs).....	10-1
10.2 DS0 "Design-To" Point.....	10-2
10.3 DS0 Terminations and Tie Cables.....	10-2
10.4 Composite Clock Requirements	10-2
10.5 Network Channel & Network Channel Interface Codes	10-3
10.6.1 Network Interface Codes	10-3
10.6.2 Network Channel Codes.....	10-4
11. Frame Relay Service.....	11-1
11.1 General.....	11-1
11.2 Network Interfaces for Frame Relay Service	11-1
11.3 Compatible Network Channel & Network Channel Interface Codes....	11-1
11.3.1 Access Port -- 56/64 kbit/s.....	11-2
11.3.2 Access Port -- Fractional 1.544 Mbit/s	11-2
11.4.3 Access Port -- 1.544 Mbit/s.....	11-2
11.4.4 Network Channel Interface Codes	11-3
12. Interconnection at Optical Carrier Levels	12-1
12.1 Connections to Unbundled Network Elements or Finished Services	12-1
12.1.1 Finished Services	12-1
12.1.2 Unbundled Network Elements and Unbundled Dark Fiber	12-1
12.2 OC-n Network Interface and "Design-To" Point	12-1
12.2.1 Fiber Cross-Connect Arrangements	12-2
12.2.2 Jumpers and Connectors -- Fiber Distribution Panel.....	12-2
12.2.3 Jumpers and Connectors -- Fiber ICDF	12-3
12.3 Optical Tie Cables	12-3
12.4 Network Channel & Network Channel Interface Codes	12-3
12.5 Synchronization.....	12-5

CONTENTS (Continued)

Chapter and Section	Page
13. Central Office Synchronization.....	13-1
13.1 General.....	13-1
13.1.1 Need for Synchronization.....	13-1
13.1.2 Stratum Levels.....	13-1
13.1.3 Primary Reference Source.....	13-3
13.1.4 QWEST Synchronization Network.....	13-3
13.1.5 Customer Requirements	13-3
13.2 Composite Clock Signal	13-5
13.3 DS1 Clock Signal	13-6
13.4 Virtual Collocation Applications	13-6
13.5 Physical Collocation Applications.....	13-7
13.5.1 Digital Connections to Metallic Loops for DS0 Digital Service...13-7	
13.5.2 Digital Connections to Other Facilities for DS0 Digital Service..13-7	
13.5.3 Voice Connections to Metallic Loops for Analog Service	13-7
13.5.4 Voice Connections to Other Facilities for Analog Service	13-8
14. Interconnection to Switched Access Service	14-1
14.1 Switched Access Service Expanded Interconnection-Collocation Termination.....	14-1
14.2 Switched Access Service -- General Description	14-1
14.3 Switched Transport.....	14-1
14.4 Network Interfaces	14-1
15. Section Has been Deleted	

CONTENTS (Continued)

Chapter and Section	Page
16. Interconnection with Finished Services	16-1
16.1 General.....	16-1
16.2 Wire Center Arrangement	16-2
16.3 Point of Termination Network Interfaces.....	16-4
16.4 Design and Provisioning Responsibilities with Finished Services	16-4
16.5 Expanded Interconnection - Collocation (EIC) in FCC #5, Section 21 .	16-5
16.5.1 Comparison of Section 21 and Other Finished Services.....	16-5
16.5.2 Services Available with EIC	16-6
16.5.3 Virtual EIC Service.....	16-6
16.5.4 Expanded Interconnection Channel Termination (EICT)	16-7
16.5.5 Analog EICT	16-8
16.5.6 Digital Data EICT	16-8
16.5.7 DS1 EICT	16-9
16.5.8 DS3 EICT	16-9
16.6 InterConnect Tie Pair (ITP).....	16-9
16.6.1 General.....	16-9
16.6.2 DS1 ITP	16-9
16.6.3 DS3 ITP	16-10
16.6.4 Optical ITP	16-11
16.6.5 DS1 and DS3 ITPs Ordered from State Tariffs.....	16-11
16.7 EICTs and ITPs Ordered from State Tariffs, Catalogs or Contracts	16-11
16.8 Direct Connection	16-12
16.9 Summary of DS1 and DS3 Finished Service NCI Code Usage.....	16-12
17. Definitions.....	17-1
17.1 Acronyms	17-1
17.2 Glossary	17-3
18. References	18-1
18.1 American National Standards Institute Documents.....	18-1
18.2 Telcordia Documents.....	18-1
18.3 QWEST Technical Publications.....	18-2
18.4 Other Publications	18-4
18.5 Ordering Information.....	18-4
18.6 Trademarks	18-5

CONTENTS (Continued)

Appendix	Page
A. Combining Unbundled Network Elements	A-1
A.1 General.....	A-1
A.2 Example 1 -- Loop Only, Connection to Collocated Equipment.....	A-2
A.3 Example 2 -- Non-Loaded Loop Only For DS1 Transport.....	A-3
A.4 Example 3 -- DS1 Transport, Regenerator and Loop	A-3
A.5 Example 4 -- Loop and DS1 Transport with Collocation	A-5
A.6 Example 5 -- Loop, Collocated Equipment and Finished Service.....	A-6
A.7 Example 6 -- Loop, Multiplexers and DS3 Transport	A-8
A.8 Example 7 -- Loop, Switch and DS1 Transport.....	A-9
A.9 Typical Ordering Process -- An Example	A-9
A.9.1 General.....	A-10
A.9.2 The Steps -- Single Collocation Example	A-10
A.9.3 The Steps -- Collocation in Both Wire Centers Example	A-13
B. Unbundled Network Elements (UNEs) and Related Topics.....	B-1
B.1 Unbundled Loop UNE	B-1
B.1.1 Network Interface Description.....	B-1
B.1.2 Unbundled Analog Loop	B-2
B.1.3 Unbundled Digital Non-Loaded Loops.....	B-2
B.1.4 DS1 Capable Loop.....	B-3
B.1.5 Applicable Network Channel & Channel Interface Codes.....	B-3
B.1.6 Design Responsibilities	B-6
B.2 Unbundled Dedicated Interoffice Transport (UDIT) Element	B-6
B.2.1 UNE Description	B-6
B.2.2 DS3 UDIT Elements	B-6
B.2.3 DS1 UDIT Elements	B-9
B.2.4 DS0 UDIT	B-11
B.2.5 Unbundled Customer Controlled Reconfiguration Element	B-11
B.2.6 OC-n UDIT Elements.....	B-12
B.2.7 Extended-UDIT Elements	B-13
B.2.8 Future UDIT Enhancements.....	B-13
B.3 Unbundled Dark Fiber	B-13
B.4 Unbundled Switch Elements.....	B-15
B.4.1 Unbundled Analog Line Port Service	B-15
B.4.2 Unbundled DS1 Trunk Port Service.....	B-15
B.4.3 Unbundled Direct Inward Dial Trunk Port Service.....	B-15
B.4.4 Unbundled Basic Rate ISDN Port Service	B-16
B.4.5 Unbundled Primary Rate ISDN Port Service.....	B-16

B.5 Other Unbundled Network Elements..... B-16

CONTENTS (Continued)

Tables	Page
3-1 Comparison of ICDF and Direct Connection - POT Arrangements.....	3-30
4-1 Collocation Comparison Summary Collocation Comparison Summary	4-7
6-1 NCI Impedance Values	6-3
6-2 NCI Transmission Levels.....	6-5
6-3 NC and NCI Codes for Ordering Jumpers.....	6-6
6-4 NC Code Definitions	6-6
6-5 NCI Code Definitions	6-7
7-1 Applicable DS3 NCI Codes for UNEs.....	7-3
7-2 Applicable DS3 "Design-To" Codes.....	7-3
7-3 Commonly Used NC Codes for DS3 Services or UNEs	7-4
8-1 Applicable DS1 NCI Codes for UNEs.....	8-2
8-2 Applicable DS1 "Design-To" Codes.....	8-3
8-3 Commonly Used NC Codes For DS1 Services or UNEs	8-4
9-1 Applicable Analog Voice Level NCI Codes for UNEs	9-3
9-2 Commonly Used NC Codes for Analog UNEs	9-4
9-3 Commonly Used NCI Codes for Analog UNEs	9-4
9-4 NCI Protocol and Protocol Option Codes	9-5
10-1 NCI Code Options -- DDS and ISDN.....	10-4
10-2 Digital Data Channel Applications	10-5
11-1 Codes for a Frame Relay Service Application at 56/64 kbit/s.....	11-2
11-2 Codes for a Frame Relay Service Application for Fractional DS1	11-2
11-3 Codes for a Frame Relay Service Application at 1.544 Mbit/s.....	11-3
11-4 Applicable NCI Codes at POT	11-3
12-1 Jumper Cable Physical Connector Specifications.....	12-2
12-2 Applicable OC-n Level NCI Codes	12-5
12-3 Common OC-n Network Channel Codes	12-5
13-1 Stratum Level Specifications	13-2
13-2 Expected Slip Performance in Holdover	13-2
15-1 DSX-1 and DSX-3 Maximum Cable and Jumper Lengths.....	15-2
15-2 Applicable Network Channel and Network Channel Interface Codes	15-6
16-1 Typical Finished Services Available with EICTs and ITPs	16-5
16-2 Summary of DS1 and DS3 EICT and ITP Network Interfaces	16-10
B-1 Unbundled Loop UNE NC and NCI Codes.....	B-4
B-2 Applicable DS3 Network Channel Interface Codes -- DS3 UDIT.....	B-7
B-3 Applicable DS3 Network Channel Codes -- DS3 UDIT	B-7
B-4 Applicable DS1 NC and NCI Codes -- DS1 UDIT.....	B-10
B-5 Two-Point OC-n UDIT Network Channel Codes	B-12
B-6 OC-n UDIT Network Channel Interface Codes.....	B-13
B-7 Available Dark Fiber NCI Codes.....	B-14

B-8 Dark Fiber NC and NCI Code Combinations..... B-14

CONTENTS (Continued)

Figures	Page
2-1 Fiber Entrance Facility Arrangements	2-5
2-2 Fiber Distribution Frame Detail.....	2-6
2-3 Microwave Entrance Facility Arrangement.....	2-12
3-1 Typical Wire Center Arrangement.....	3-2
3-2 Typical Network Interface Arrangement.....	3-5
3-3 Generic DS0/Voice Interconnection Arrangement.....	3-11
3-4 DS0/Voice ICDF Arrangement.....	3-12
3-5 Typical DS1 or DS3 ICDF Arrangement.....	3-14
3-6 DS1/DS3 Signal Flow Between IDE and UNE	3-15
3-7 Fiber ICDF Arrangement.....	3-16
3-8 Typical Standard ICDF Arrangement.....	3-19
3-9 Typical Direct Connection - POT Arrangement.....	3-21
3-10 Another Direct Connection-POT Arrangement	3-23
5-1 Typical Wire Center Arrangement.....	5-2
5-2 Configurations for Multiple Equipment Locations.....	5-6
6-1 Format Structure for NC Codes.....	6-1
6-2 Format Structure for NCI Codes.....	6-3
12-1 Fiber ICDF Arrangement	12-4
13-1 Typical QWEST BITS Arrangement.....	13-4
13-2 DS0 and Composite Clock Signal Timing	13-5
13-3 Composite Clock Waveform	13-6
15-1 Typical DSX Arrangement.....	15-1
15-2 Interconnection Application.....	15-3
15-3 DS1 or DS3 Regenerator Option Arrangement	15-5
15-4 DS1 Regenerator Option Code Usage Example	15-6
15-5 Electronic Cross-Connect Wire Center	15-7
16-1 Typical Wire Center Arrangement for Finished Services	16-2
16-2 FCC #5, Section 21 EICT/ITP Arrangement.....	16-6
A-1 Unbundled Loop to Collocated Equipment.....	A-2
A-2 Unbundled Loop for DS1 and Collocation.....	A-3
A-3 DS1 Transport, Regenerator and Loop	A-4
A-4 Unbundled Loop, Collocation and DS1 UDIT.....	A-5
A-5 Connections with Finished Services.....	A-6
A-6 Loop, Multiplex and DS3 Transport Example.....	A-8
A-7 Loop, Switch and DS1 Transport Example	A-9
A-8 Typical Ordering Process Example	A-12
B-1 Typical 2-Wire Unbundled Loop UNE Configuration.....	B-3
B-2 Typical DS3 Two-Point UDIT UNE.....	B-8
B-3 Typical DS3 UDIT Multiplexer UNE	B-9
B-4 Typical DS1 Two-Point UDIT UNE.....	B-10
B-5 Typical DS1 UDIT Multiplexer UNE	B-11

B-6 Typical OC-n Two-Point UDIT Element B-12

CONTENTS

Chapter and Section	Page
1. Introduction	1-1
1.1 General.....	1-1
1.2 Reason for Reissue	1-1
1.3 Purpose and Service Availability	1-1
1.4 Scope	1-2
1.5 Terminology.....	1-2
1.5.1 Interconnectors	1-2
1.5.2 Interconnector Designated Equipment.....	1-2
1.5.3 Tariffs, Catalogs and Contracts.....	1-2
1.5.4 Competitive Local Exchange Carrier, Co-Provider	1-2
1.5.5 Unbundled Network Element (UNE)	1-3
1.5.6 Finished Service.....	1-3
1.5.7 Expanded Interconnection Channel Termination.....	1-3
1.5.8 NIs, POTs and POIs	1-3
1.6 General Requirements.....	1-5
1.7 Non-Access Private Line Services	1-5
1.8 Responsibilities.....	1-6
1.9 General Information Source	1-6
1.10 Document Organization.....	1-6

1. Introduction

1.1 General

This document provides technical information about Interconnection and Collocation with Qwest for Private Line Transport and Switched services as well as any Unbundled Network Elements (UNEs) sold by Qwest. Also included are descriptions of Physical, Virtual, Shared Physical, Cageless Physical and InterConnection Distribution Frame Collocation. Generalized descriptions and examples of Network Channel and Network Channel Interface codes are also included. The Interconnector will need to use this information when collocating in Qwest wire centers and connecting to Qwest transport and switched services or UNEs. These include, for example, DS3 Service, DS1 Service, Analog Private Line Transport Service, Digital Data Service, Frame Relay Service and various similar UNEs.

CLECs collocated equipment must comply with Network Equipment Building System (NEBS) Level 1 safety standards and any statutory (local, state or federal) and/or regulatory requirements in effect at the time of equipment installation or that subsequently become effective. Qwest complies with all standards and requirements according to NEBS Level 1 and Qwest Technical Publications. Qwest shall not impose safety and engineering requirements on CLECs that are more stringent than the safety or engineering requirements Qwest imposes on its own equipment located on its Premises.

1.2 Reason for Reissue

This publication has been revised to:

- Add language to Chapter 12 to change Qwest fiber optic connector standard from FC-UPC to SC-UPC.

1.3 Purpose and Service Availability

This document describes Collocation relating to a variety of services or UNEs. The availability of these services, UNEs, Interconnection arrangements and types of collocation varies in different regulatory jurisdictions. Certain parameters in this publication may be superseded by tariffs, catalogs, contracts or regulatory order and may be jurisdiction-specific. Check the appropriate resource for further information.

Some services, Interconnection arrangements, options, and types of collocation described in the document may not be in an existing contract. The contract may have to be amended under these circumstances.

1.4 Scope

This document is to be used with other Technical Publications that describe the specific services or UNEs offered by Qwest. The publications are listed in the chapters about the specific service or UNEs. These publications contain further information about the network interfaces. Applicable Network Channel and Network Channel Interface codes used with Interconnection are listed in this document.

The primary focus of this document is to provide technical information. Other documents should be consulted for ordering procedures, security and other operational processes. One such source is Qwest's web site: www.uswest.com/carrier/. This site contains ordering information, resource guides and other pertinent information.

1.5 Terminology

An understanding of some terms is required while reading this publication.

1.5.1 Interconnectors

Customers who have transmission equipment in a Qwest wire center through some type of collocation agreement for interconnection to Qwest's Private Line Transport, Switched Access Services, or UNEs will be termed *Interconnectors*. The term Interconnector may also apply to customers who have no transmission equipment in the wire center but purchase UNEs and combine them together to form a service for their customers.

1.5.2 Interconnector Designated Equipment

For purposes of discussion in this publication, equipment under control of an Interconnector (whether owned by the Interconnector in physical space or leased to Qwest for Virtual Collocation) will be called *Interconnector Designated Equipment* (IDE).

1.5.3 Tariffs, Catalogs and Contracts

Additional information about the services and UNEs described in this publication may be found in tariffs (State or Federal), catalogs or contracts depending on the jurisdiction. The Standard General Available Terms (SGAT) is another source of information. Information may also be found on Qwest's web site at www.uswest.com/carrier.

1.5.4 Competitive Local Exchange Carrier, Co-Provider

A Competitive Local Exchange Carrier (CLEC) is a Local Exchange Carrier (LEC) certified to do business in a state as a LEC. The terms CLEC and Interconnector may be used interchangeably in this publication since an Interconnector must be a CLEC.

The term Co-Provider is used in some contracts and other documents to denote a CLEC.

1.5.5 Unbundled Network Element (UNE)

A UNE is a portion of Qwest's network sold to an Interconnector for use in building services for their customers. The Interconnector normally would connect to these UNEs in a Qwest wire center. The Interconnector or CLEC may combine these UNEs together and/or with their own facilities or equipment for this purpose.

The Interconnector has design responsibility to insure that these elements will properly work with each other and with their facilities and equipment to meet their customer's service needs. The Interconnector has responsibility of maintaining records of all connections used in combining UNEs.

1.5.6 Finished Service

A Finished Service is any normal or traditional service sold by Qwest in a tariff, catalog or contract. The Finished Service typically consists of a number of network elements connected together in a designed fashion. Qwest assumes design and record keeping responsibility for the service. The Interconnector still has responsibility of design and records keeping of any additional facilities or equipment that are added to the Qwest-provided Finished Service. These services are described in tariffs, catalogs, contracts and technical publications.

1.5.7 Expanded Interconnection Channel Termination

The Expanded Interconnection Channel Termination (EICT) is a tariff rate element. This element is used in various arrangements to pay for tie pairs and frame terminations within the Wire Center.

1.5.8 NIs, POTs and POIs

A Network Interface (NI) is the point of demarcation on the customer's premises at which Qwest's responsibility ends. The Federal Communications Commission (FCC) defines the NI as: *The term "Network Interface (NI)" denotes the point of interconnection between Company communications facilities and terminal equipment, protective apparatus or other customer provided facilities.*

While the NI has traditionally been applied to End-User applications, the term can also apply to interfaces between Qwest and a Carrier. This publication uses the term NI to apply in both instances based on the terms *Customer* and *Customer Premises*. See Chapter 17 for further information.

NIs have been standardized for most services. The NIs may be described in FCC Rules and Regulations, technical publications issued by national or international standards bodies (such as the American National Standards Institute or ANSI), technical publications issued by a service provider (such as Qwest), and other documents.

It is Qwest's intent to utilize these national standards when available and appropriate. There may be circumstances when Qwest may choose to use a NI not nationally recognized. One such NI is the non-templated DS1 and DS3 NI described in Section 16.6 of this publication. These new NIs are based on national standards, but differ only in a different signal level. These NIs may be standard only with Qwest and were developed as a result of a customer request.

A NI has the following characteristics:

- Provides a clear physical and electrical demarcation point between Qwest and the customer.
- Provides the ability to easily open the connection to permit testing and maintenance, and then easily reconnecting the circuit for normal operation.

A Point of Termination (POT) is the physical telecommunications interface that establishes the technical interface, the test point(s), and the point(s) of operational responsibility. The FCC definition of POT in the Access tariff is *The term "Point of Termination" denotes a point at or near a Customer-designated premise at which the Company's responsibility for the provision of Access Service ends.* This NI has traditionally been applied to interfaces with Carriers for Access Services. The term can also be applied to CLECs and Unbundled Network Elements. This publication uses the term in this context but does make a distinction between a CLEC-POT and an Interexchange Carrier-POT (IC-POT).

The FCC defines a Point of Interconnection (POI) as: *The term "Point of Interconnection" denotes the Company-designated point of physical demarcation outside the Company's wire center where the Interconnector-provided and -owned fiber optic facilities end and the Company's fiber optic facilities begin for Expanded Interconnection-Collocation Service.* The acronym POI also has other meanings. To minimize confusion, this publication uses the term Collocation POI (CPOI) to uniquely apply to this meaning.

1.6 General Requirements

All equipment (IDE) installed by an Interconnector in a Qwest Wire Center must comply with the requirements of the National Electric Code®. The IDE must also comply with the with Bellcore Network Equipment Building System (NEBS) Level 1 safety standards, GR-63-CORE, *NEBS Requirements: Physical Protection*, and GR-1089-CORE, *Electromagnetic Compatibility and Electrical Safety - Generic Criteria for Network Telecommunications Equipment*. Requirements for fiber optic cables are provided in GR-20-CORE, *Generic Requirements for Optical Fiber and Fiber Optic Cable*.

The following publications will also apply for collocation:

- PUB 77350, Central Office Telecommunications Equipment Installation and Removal Guidelines
- PUB 77351, Qwest Communications, Inc. Engineering Standards (three modules)
- PUB 77355, Grounding-Central Office and Remote Equipment Environment
- PUB 77385, Power Equipment and Engineering Standards.

Appropriate sections of the publications must be followed when collocating equipment in a Qwest wire center.

Other requirements of Qwest or of a regulatory and statutory nature may apply. See the appropriate tariff, catalog or contract for further information.

Additional information may also be found on Qwest's web site at:

www.qwest.com/Wholesale/clecs

1.7 Non-Access Private Line Services

Qwest provides end-to-end Private Line Transport Services (PLTS) within a Local Access and Transport Area (LATA). These services have been called Non-Access or IntraLATA services. This situation changes with the introduction of CLECs. A service may still be within a LATA (i.e., intraLATA) but now may be jointly provided by both a CLEC and Qwest. The portion of the service ordered from Qwest is now an Access Service.

The technical parameters for Access Services may differ from those of end-to-end Non-Access services. This is especially true of analog PLTS. Normally, the Non-Access end-to-end technical parameters of a service provided by a LEC are the same as the end-to-end service provided by multiple providers (i.e., a LEC(s) and an Interconnector, CLEC or Interexchange Carrier).

Thus, when consulting other publications for further technical details, references to “Access” services should be used. Later chapters in this publication provide information that is more specific.

1.8 Responsibilities

Qwest will work cooperatively with the Interconnector for engineering and design, installation, testing and repair or maintenance as described in the appropriate tariff, catalog or contract.

The Interconnector’s facilities must not physically, electrically, or inductively interfere with Qwest’s or another Interconnector’s or tenant’s facilities.

Qwest will provide the Interconnector information about the facility that will be connected to the Interconnector’s service. The Interconnector will provide information about the frame termination where Qwest will connect their service.

1.9 General Information Source

A reader needing some general background information about LEC networks may find SR-2275, *BOC Notes on the LEC Networks*, to be of value. This Telcordia Special Report contains generic information about technologies and topics found in a LEC network.

1.10 Document Organization

This document is organized as follows:

- Chapter 1 Introduction: Provides the purpose, scope, basic terminology and organization of the document.
- Chapter 2 Introduction to Collocation and Interconnection: Describes the basic concept of Interconnection and Collocation. Describes facility types available to gain access to the Qwest wire center.
- Chapter 3 Interconnection Arrangements: Describes the Interconnection arrangements available to a CLEC. Describes interconnection between two CLECs.
- Chapter 4 Types of Collocation: Describes the types of Collocation.
- Chapter 5 Responsibilities: Defines the CLEC’s and Qwest’s responsibilities involved with Interconnection and Collocation.
- Chapter 6 Network Channel and Network Channel Interface Codes - General: Provides some basic information about the two types of codes. Lists codes to be used to order jumpers.

- Chapter 7 DS3 Interconnection: Provides information about DS3 Interconnection to UNEs or Finished Services.
- Chapter 8 DS1 Interconnection: Provides information about DS1 Interconnection to UNEs or Finished Services.
- Chapter 9 Analog Interconnection: Provides information about analog Interconnection to UNEs or Finished Services.
- Chapter 10 Interconnection at DS0 Digital Level: Provides information about digital data Interconnection to UNEs or Finished Services at the DS0 level.
- Chapter 11 Frame Relay Service: Provides information about connecting to the Frame Relay Service.
- Chapter 12 Interconnection at Optical Carrier Levels: Provides information about Optical Interconnection to UNEs or Finished Services.
- Chapter 13 Central Office Synchronization: Provides description of synchronization signals and application information.
- Chapter 14 Interconnection to Switched Access Service: Provides information about connections to Switched Access Service.
- Chapter 16 Interconnection with Finished Services: Describes the Network Interface for Expanded Interconnection Channel Termination (EICT).
- Chapter 17 Definitions. A glossary.
- Chapter 18 References: Includes titles and ordering instructions for documents referenced in this publication.
- Appendix A Combining Unbundled Network Elements: Illustrates proper Network Channel and Network Channel Interface code usage in situations where the Interconnector wishes to connect UNEs together.
- Appendix B Unbundled Network Elements: Provides information about some UNEs available from Qwest.

CONTENTS

Chapter and Section	Page
2. Introduction to Collocation and Interconnection	2-1
2.1 General Concept.....	2-1
2.2 Collocation	2-1
2.3 Unbundled Network Elements (UNEs).....	2-2
2.4 Finished Services.....	2-2
2.5 Network Interfaces	2-2
2.5.1 Network Interfaces for UNEs.....	2-2
2.5.2 Network Interfaces for Finished Services.....	2-2
2.6 Interconnection Arrangements	2-3
2.7 Transport Access to the Qwest Wire Center	2-3
2.7.1 Collocation Point of Interconnection (CPOI)	2-4
2.7.2 Standard Fiber Entrance Facilities and Related Topics	2-4
2.7.2.1 Standard Entrance Facility (Option 1).....	2-7
2.7.2.2 Cross Connect (Option 2)	2-7
2.7.2.3 Express Fiber Entrance (Option 3).....	2-8
2.7.3 Non-Standard Metallic Pair Entrance Facilities.....	2-9
2.7.4 Non-Standard Coaxial Entrance Facilities.....	2-10
2.7.5 Non-Standard Microwave Entrance Facilities	2-10
2.7.6 Finished Services Instead of Entrance Facilities	2-11
2.8 Facility Connected (FC) Collocation	2-12
2.8.1 FC Collocation Copper Facilities	2-12
2.8.1.2 DS0 FC Collocation	2-15
2.8.1.2 DS1 FC Collocation	2-15
2.8.1.3 DS1 FC Collocation.....	2-15
2.8.2 Fiber Entrance Facility for FC Collocation	2-17
2.8.3 Non-Standard FC Collocation Entrance Facility	2-17
2.9 Equipment and Wiring Requirements.....	2-18

Figures

2-1 Fiber Entrance Facility Arrangements	2-5
2-2 Fiber Distribution Frame Detail.....	2-6
2-3 Microwave Entrance Facility Arrangement.....	2-12
2-4 DS0 FC Collocation, Example 1	2-15
2-5 DS0 FC Collocation, Example 2	2-15
2-6 DS0 FC Collocation, Example 3	2-16
2-7 Typical DS1 FC Collocation Example	2-16

2. Introduction to Collocation and Interconnection

2.1 General Concept

This chapter introduces the types of Interconnection and the types of Collocation available for Interconnection. The availability of these types is also described in the appropriate tariff, catalog or contract. Regulatory orders may also impact availability and description. Drawings in this and subsequent chapters illustrate various arrangements.

The concept behind Interconnection described in this publication is to permit a Competitive Local Exchange Carrier (CLEC) to interconnect with Qwest facilities to provide a service to the CLEC's customer. The CLEC may purchase various Unbundled Network Elements (UNEs) and/or Finished Services from Qwest and combine them together to provide these services. The CLEC may optionally add their own equipment and facilities to these UNEs and/or Finished Services.

The transmission equipment collocated in a Qwest wire center is called *Interconnector Designated Equipment (IDE)*. Further information about IDE may be found in Section 2.8.

2.2 Collocation

Collocation is available in all wire centers that have vacant equipment space. Space limitations may restrict the availability of some types of Collocation. CLECs may make additional requests by using the established Bona Fide Request process.

Several forms of Collocation may be available in a wire center. They include Virtual Collocation, Caged Physical Collocation, Shared Caged Physical Collocation, Cageless Physical Collocation, InterConnection Distribution Frame (ICDF) Collocation, Adjacent Collocation, Common Area Splitter Collocation, Remote Collocation. Further information about these forms of Collocation may be found in Chapter 4.

CLEC may collocate any equipment that is necessary for interconnection or access to unbundled network elements (UNEs) such as DSLAMS, ATMs, or packet switching equipment. Remote Switching Units (RSUs) also meet this legal standard when used for Interconnection or access to unbundled network elements.

NOTE: Before any type of CLEC switching equipment is collocated, the CLEC must provide to Qwest an inventory of the associated equipment and how it is intended to be used for Interconnection or access to Unbundled Network Elements.

2.3 Unbundled Network Elements (UNEs)

Several types of UNEs are available from Qwest. They include Unbundled Loops, Unbundled Dedicated Interoffice Transport, Unbundled Switch Ports (both line-side and trunk-side) and others. Further information about these UNEs may be found in Appendix B of this publication and in the Technical Publications described in Appendix B. Collocation in some form is required for a CLEC to have access to the various Qwest-provided UNEs.

2.4 Finished Services

A Finished Service is a service sold by Qwest in tariffs or catalogs. They are not UNEs. These Finished Services are described in the tariffs, catalogs and in various Technical Publications. They are not normally sold by contract.

Finished Services may be ordered to a Point of Termination (POT). The POT serves as the Network Interface between Qwest and the CLEC for finished services. The CLEC may then connect the Finished Services to their equipment or to UNEs. Chapter 16 provides further information.

2.5 Network Interfaces

A Network Interface (NI) is the interface between Qwest and the CLEC.

2.5.1 Network Interfaces for UNEs

The NI between the collocated CLEC and Qwest UNEs for all types of Collocation and Interconnection is at a cross-connect frame. The type of frame depends on the level (i.e., DS0 or voice, DS1, DS3, and fiber or optical) of the channel and the Interconnection arrangement. Specifically, the NI will be the pin, jack or connector on the cross-connect frame that Qwest identifies as the point at which a jumper may be placed to connect the UNE to another UNE or the CLEC's IDE. This publication will assume that the NI is a cross-connect frame generically called the ICDF.

There will be a cable connecting to Qwest facilities and equipment on the other side of the NI. The NI may appear on the "horizontal" side or the "vertical" side of the frame depending on the UNE. The specifics of the NI are explained in later chapters.

Either the CLEC or Qwest (if ordered by the CLEC) will supply the cable(s) between the IDE and the NI for UNE terminations.

2.5.2 Network Interfaces for Finished Services.

All Finished Services being delivered to a collocated CLEC in the wire center will terminate at a POT. The POT will be located near the CLEC's area in the wire center. The CLEC will have to extend these services from the POT to their equipment area.

2.6 Interconnection Arrangements

Up to two (2) Interconnection arrangements may be available in a specific wire center. The Interconnection arrangements are based on the type of NI used to interconnect with Qwest UNEs. Special design considerations and responsibilities will apply with the different arrangements.

The cross-connect frames used for the NIs are Intermediate Distribution Frames (IDFs) called InterConnection Distribution Frame (ICDF) frames. These arrangements use a common or shared ICDF or a Direct Connection - Point of Termination. The latter is dedicated for the sole use of one CLEC

These Interconnection arrangements are defined in Chapter 4.

Qwest will provide a connection between unbundled network elements and ancillary services and a demarcation point. Such connection is an Interconnection Tie Pair (ITP). The demarcation point shall be:

1. at CLEC-provided cross-connection equipment located in CLEC's Virtual or Physical Collocation Space; or
2. if CLEC elects to use ICDF Collocation, at the Interconnection Distribution Frame (ICDF); or
3. if CLEC elects to use an ICDF in association with Virtual or Physical Collocation, at the ICDF;
4. at a direct connection point of termination.
5. at another demarcation point mutually-agreed to by the Parties.

To the extent possible, Qwest shall make contiguous space available to a CLEC when it seeks to expand its existing Collocation space. Where adjoining space is not available, the CLEC may provide interconnection facilities between the non-adjointing CLEC Collocation spaces through CLEC-to-CLEC connections.

2.7 Transport Access to the Qwest Wire Center

The CLEC placing or collocating IDE in the Wire Center will require a transport facility to gain access to the Qwest wire center. Three of the options that the CLEC may use to gain access are by purchasing Finished Services from Qwest, by connection to an Entrance Facility, or by ordering Extended-Unbundled Dedicated Interoffice Transport. See Section B.2.7 for further information about the latter option.

The standard Fiber Entrance Facility consists of a Qwest-owned cable. This cable is placed from a Collocation Point of Interconnection (CPOI) outside the wire center into the wire center using existing conduit structure. The cable then connects to the CLEC's collocated IDE. The CLEC's fiber cable is spliced to this facility at the CPOI.

Some non-fiber arrangements may be available under certain circumstances. The description will vary depending on the technology.

In the state of Minnesota only, a Metallic Entrance Facility is standard and is provided on Individual Case Basis (ICB) intervals and pricing.

2.7.1 Collocation Point of Interconnection (CPOI)

The CPOI is the Qwest-designated point of physical demarcation outside the Qwest wire center where the Interconnector-provided and owned fiber optic (or other) facilities end and Qwest's fiber optic facilities begin. These cables are used as an Entrance Facility to enter the wire center for purposes of collocation. The CPOI is typically located in a manhole adjacent to the wire center. However, in some congested areas, the CPOI may be further from the wire center. Qwest will assist with the placement of the Interconnector's cable into the CPOI and will perform all splicing of the cable to the Entrance Facility. The exact function of the CPOI depends on which alternative of entering the wire center is selected.

Interconnectors will be allowed access to the CPOI on non-discriminatory terms.

The normal type of Entrance Facility is a fiber cable. However, under certain circumstances, other types of entrance facilities may be available. The following sections describe specific details of the various types of entrance facilities.

Diverse Entrance Facilities may be available in some wire centers.

2.7.2 Standard Fiber Entrance Facilities and Related Topics

The Fiber Entrance Facility includes the conduit and building riser structure between the CPOI and the Collocated IDE. This facility will be provisioned and maintained by Qwest. The costs for this construction will be calculated according to the provisions of this service offering. Ownership of the fiber cable itself will depend on the alternative selected.

Figure 2-1 illustrates a typical arrangement using a Fiber Entrance Facility. The Fiber Entrance Facility, some IDE, and cable from the IDE to the NI frame are included. The figure also shows UNEs connected at the NI. A POT is also included.

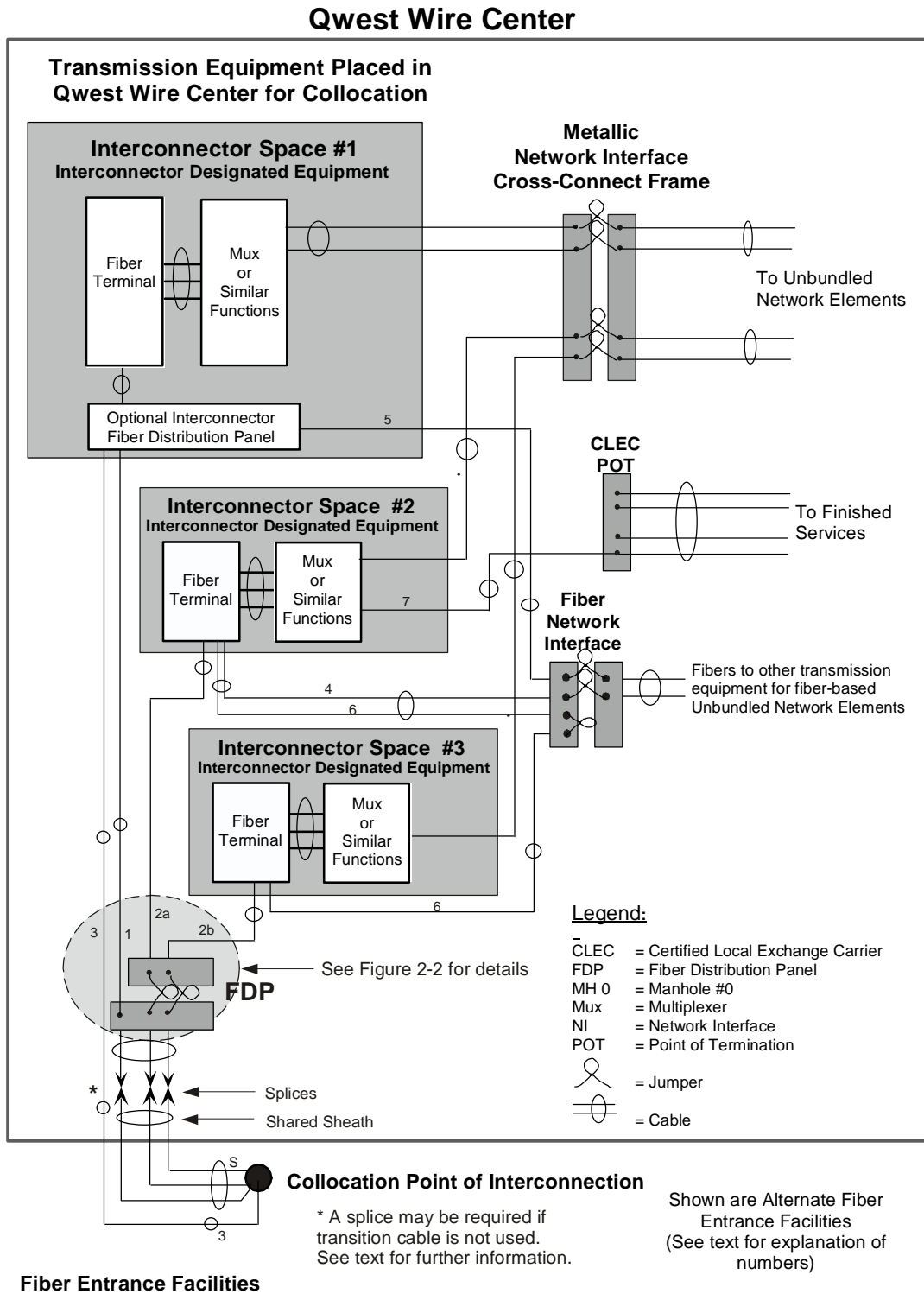

Figure 2-1 Fiber Entrance Facility Arrangements

In this context, the “Entrance Facility” is not the same facility as used for some Finished Services.

Three types of Fiber Entrance Facilities are shown: the standard (#1) and two alternate arrangements (#2 and #3).

Figure 2-2 illustrates the details of the Fiber Distribution Frame with two FDPs from the Figure 2-1 arrangement.

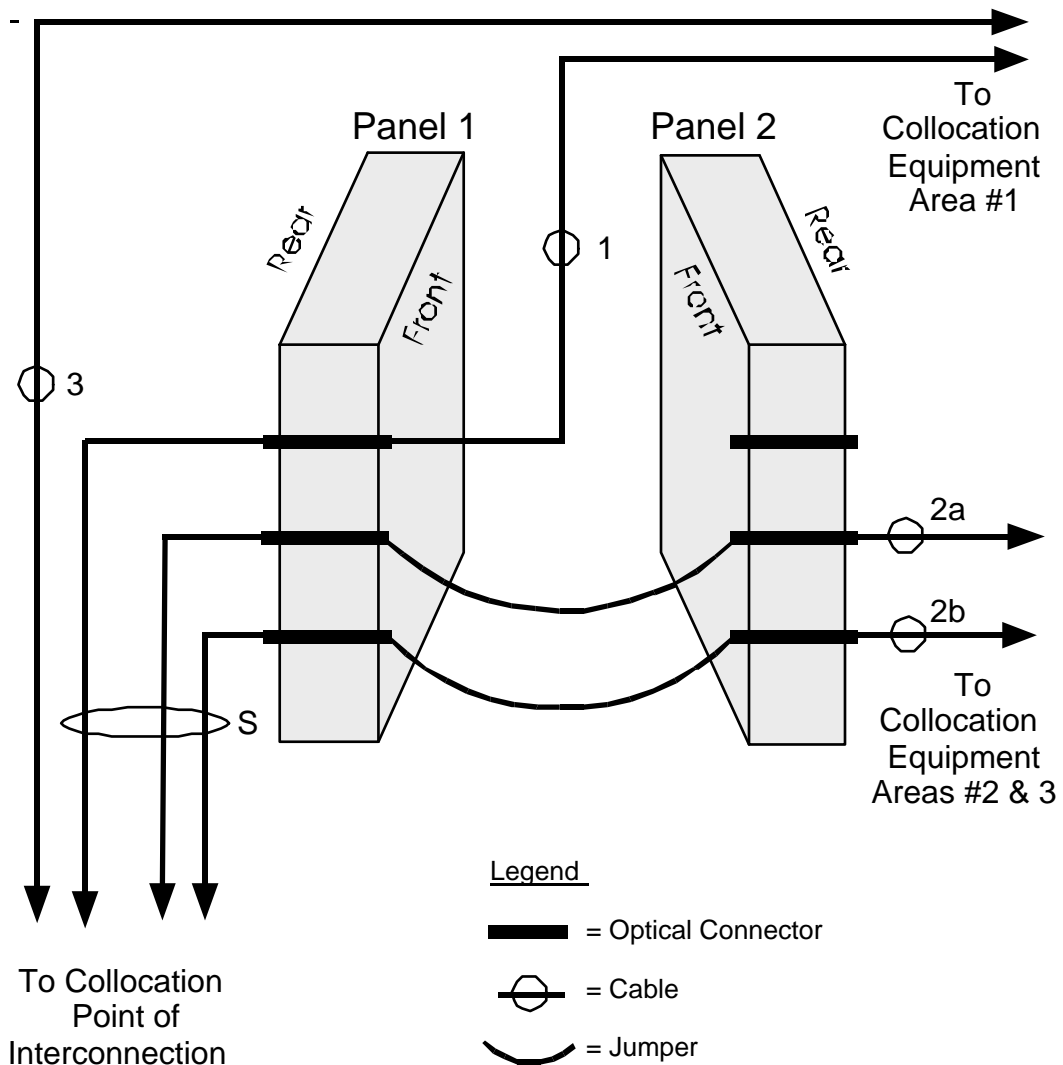

Figure 2-2 Fiber Distribution Frame Detail

2.7.2.1 Standard Entrance Facility (Option #1)

The shared fiber cable (#S) goes from the CPOI into the wire center. This shared sheath is used to get inside the wire center and minimize costs for conduit, cable and entrance space in the wire center vault. A splice is located inside the wire center where the cable sheath is converted from an outside cable to a fire-rated inside cable sheath. The cable terminates on the rear of a Fiber Distribution Panel (FDP) as illustrated in Figure 2-2.

A cable is placed from the front side of the FDP directly to a CLEC's space. This arrangement has limited flexibility since the entire entrance facility (12 fiber multiples) goes to only one (1) CLEC space. Alternative #2 (Cross-Connect option) should be used if there is a need to go to multiple CLEC spaces.

This standard arrangement may be used for all forms of Collocation.

Qwest owned fiber cable from the CPOI to the IDE location will be placed by Qwest. Each cable is available in multiples of twelve (12) fibers. This cable will be single-mode fiber optic cable that meets the requirements of GR-20-CORE, *Generic Requirements for Optical Fiber and Fiber Optic Cable*. Splicing at the CPOI will be done by Qwest in conjunction with the Interconnector. The costs for this construction will be calculated according to the provisions of this service offering.

2.7.2.2 Cross-Connect Option (Option #2)

The first alternate arrangement (#2 in Figures 2-1 and 2-2) places a cable from the rear of the second panel to the CLEC's space. Multiple cables may be placed to multiple spaces.

Cross-connects are placed on the front of the FDPs to connect to fiber cables going to a CLEC's space in the wire center to the cable from the POI. In Figures 2-1 and 2-2, cables designated as 2a and 2b go to Interconnector Spaces #2 and #3. These spaces may be used by the same or by different CLECs.

This arrangement provides maximum flexibility and potentially reduced costs. For example, if the same CLEC has both spaces #2 and #3, the CLEC could use twelve fibers from the CPOI to the FDP rather than 24 fibers if the total required for both spaces does not exceed twelve. The cable from the FDP to each IDE space could be either four (4) or twelve (12) fibers.

This option also supports transitions from one form of collocation to another.

However, this alternative provides more loss due to the jumper and connectors on the second panel.

The cables must be as described in the standard arrangement above.

2.7.2.3 Express Fiber Entrance - (Option #3)

Also shown is another alternate arrangement where a cable (#3) is placed directly from the CPOI to the optional CLEC FDP or IDE located inside the Interconnector's space.

This alternative is available **ONLY** for Physical Collocation as described in Section 4.3. Other forms of collocation must use the other arrangements described above. This alternative provides a dedicated entrance facility directly from the CPOI to the CLECs Physical Collocation space.

This cable must be a "transition" cable. The sheath on this cable must be suitable for both inside and outside placement. The "transition" cable sheath must meet appropriate fire and safety requirements including those of the National Electric Code, i.e., fire rated, Outside Plant Sheath.

The size of the cable is determined by the CLEC. Only one such cable sheath will be permitted per Physical Collocation area.

This alternative entrance facility does not provide any access for Qwest to perform testing. Thus, the CLEC has full responsibility for the cable other than the placement of the cable. The fiber cable, supplied by the CLEC, will be placed by Qwest. Any future maintenance work involving work on the cable in duct or cable rack area must involve Qwest.

This alternative will be available only in wire centers with sufficient entrance duct and innerduct availability. Qwest reserves the right to maintain one vacant duct for metallic emergency restoration and one vacant innerduct for fiber emergency restoration. In addition, Qwest will reserve one innerduct for a shared fiber entrance facility if not already in place.

2.7.2.4 Fiber Cables -- General

Qwest will designate the path and cable racking for these cables.

Chapter 12 contains additional information about the Fiber NIs and fiber jumpers.

Fiber cable from the Fiber NI to the IDE may be provided by the Interconnector or obtained from Qwest. In the latter case, the cable is available in multiples of twelve (12) fibers. The cable in either case will be installed and maintained by Qwest.

2.7.3 Non-Standard Metallic Pair Entrance Facilities

Some regulatory jurisdictions have specified that Metallic Entrance Facilities may be used as an alternative to the Fiber Entrance Facility. Metallic Entrance Facilities in these jurisdictions are available to CLECs on a contractual basis. Orders for Metallic Pair Entrance Facilities are placed via the normal BFR collocation order process. Such entrance facilities, where available, will be designed in a manner as other metallic cables are placed into the wire center. This section contains some of the technical requirements involved. Other terms, conditions and specific information may be obtained from Qwest concerning a specific wire center. Further information may be found in the appropriate technical publication, tariff, catalog or contract.

NOTE: Metallic Entrance Facilities in Minnesota only are considered a standard entrance facility and are offered on ICB intervals and pricing.

Metallic Pair Entrance Facilities will also be available to CLECs using Adjacent Space Collocation as described in Section 4.7.

The issues involved with a Metallic Entrance Facility are similar to those of the standard Fiber Entrance Facility. The differences are based on the inherent differences in the technology. A full conduit entrance duct, for example, will be required between the designated CPOI and the cable vault in the Wire Center rather than the innerduct approach used with the fiber facility.

The metallic CPOI may be a different location than the CPOI used for Fiber Entrance Facilities.

All equipment and fire protection standards must meet appropriate safety standards including, but not limited to, the Network Equipment - Building System (NEBS) Level 1 safety standards, (FR-2063), National Electric Code (NEC), Occupational Safety and Health Administration (OSHA) and various federal, state and local regulations.

All metallic pairs must be terminated on a protector frame. The Interconnector has the option of either using Qwest's protector frame or supplying frame. Grounding of the cable will be completed in the cable vault per PUB 77355, *Grounding - Central Office and Remote Equipment Environment*. Any protector frame must meet standard Qwest requirements including Chapter 6 of PUB 77355.

Qwest will place a cable (provided by the Interconnector or ordered from Qwest) from the protector frame to the vault where it will be straight spliced into the Interconnector's cable.

The collocation space normally will be limited to the first two floors of a wire center. This is to protect Qwest's network from high voltage associated with exposed copper cable based on NEC requirements. This space should be directly above, or in

as close as possible above, the cable vault. This is required to minimize electrical influence on adjacent cable and racking.

There may be some wire centers where space is not available for a properly located, CLEC-owned protector frame. The CLEC must use the Qwest-owned protector frame under these circumstances.

Qwest will designate the path and cable racking for the entrance cable into the vault. The Interconnector will provide sufficient cable so that the cable can be pulled from the CPOI utility hole into the vault. Qwest will provide the Interconnector with the cable footage requirements.

Interconnectors will be provided two points of entry into the Qwest wire center where there are at least two existing entry points used for Qwest cable with available spare ducts.

2.7.4 Non-Standard Coaxial Entrance Facilities

Coaxial Entrance Facilities are available for limited transport applications such as DS3 as described in the appropriate tariff, catalog or contract. The CLEC must submit a Bonafide Request (BFR). The specifications and requirements are similar to those of the metallic paired Entrance Facility. The application must meet acceptable standards including those in ANSI T1.102-1993, *Digital Hierarchy -- Digital Interfaces*.

The CLEC must provide any repeaters required. The CLEC must determine the need for these devices based on their facilities, any IDE and potential connections to UNEs or services.

The coaxial Entrance Facility will require a full duct between the designated CPOI and the cable vault.

2.7.5 Non-Standard Microwave Entrance Facilities

A Microwave Entrance Facility permits a CLEC to lease spare microwave tower space on a Qwest microwave tower. This space is for a microwave antenna to be used as an Entrance Facility to a Qwest wire center to be used for purposes of collocation. This type of Entrance Facility may be used instead of a cable Entrance Facility.

A Microwave Entrance Facility is available with Virtual, Physical, Shared and Cageless Physical Collocation where space permits.

The appropriate tariff, catalog or contract should be consulted for availability and other information.

The requirements for contractors working on Qwest's towers are described in PUB 77360, *Contractor's Specification Standards for Antenna and Waveguide Installation, Maintenance and Removal*. Other technical requirements are still under development and this information should be considered preliminary.

Qwest will lease spare microwave tower space to Interconnectors for placing their antenna for connection to their IDE. This IDE is to be used to interconnect to Qwest UNEs or Finished Services. The tower space will be on towers contiguous to or on Qwest's wire centers.

Qwest will designate the path and racking for the Entrance Facility from the antenna to the IDE location. Qwest will provide dry air as described in PUB 77360.

Associated wire center floor space requirements will be handled through the floor space procedures.

Spare microwave tower space will be assessed in terms of physical and structural loading constraints. Microwave frequency use will be limited by frequency availability to avoid Radio Frequency Interference.

The CLEC will have to provide Qwest with technical requirements (such as those in PUB 77355) including the following:

- Type of antenna mount (pipe, non-penetrating roof mount)
- Type of equipment to be collocated (vendor, capacity)
- Line of sight requirements (Azimuth)
- Relevant information including: Station Name, Call Sign, Latitude, Longitude, Primary Antenna Type, Antenna Center Line (C/L), Antenna Gain, Diversity Antenna type (if used), Diversity Antenna C/L, Diversity Antenna Gain, Equipment Type, Equipment Emission, Power (dBm/Watts), Receive Level (dBm), EIRP (dBm/Watts), Transmit Frequency (MHz)
- Other relevant information as identified at a site visit or other time

Figure 2-3 is a simplified version of Figure 2-1 illustrating the Microwave Entrance Facility.

Other specific details will be included in the contract.

2.7.6 Finished Services Instead of Entrance Facilities

The CLEC may choose to purchase a finished service (such as DS1 or DS3 Service) to gain access to the Qwest wire center. See Chapter 16 for further information.

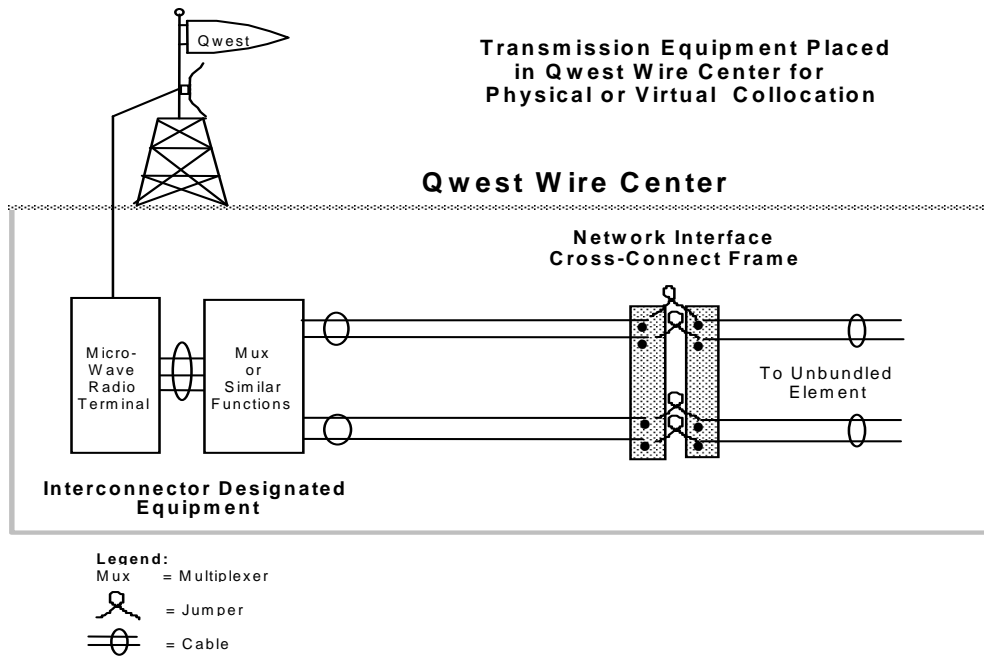

Figure 2-3 Microwave Entrance Facility Arrangement

2.8 Facility Connected (FC) Collocation

Qwest Facility Connected (FC) Collocation is available for CLECs/DLECs that need to access Qwest's UNEs, Ancillary Services, or Finished Services within a Qwest CO without establishing an actual physical collocation at the associated Qwest CO. FC Collocation utilized the various different types of entrance facilities to allow the CLECs to access the desired Qwest's UNEs, Ancillary Services, or Finished Services within a Qwest CO.

2.8.1 Copper Entrance Facility

2.8.1.1 FC Collocation is available at the Digital Service Level 0 (DS0) for termination and cross-connection to appropriate DS0 UNE services. Standard DS0 Network Channel (NC) and Network Channel Interface (NCI) codes should be used. When a splitter is required, the Network Interface (NI) in this situation will be a two wire interface that will carry a signal of either voice or data, or a combined signal of voice and data. When a splitter is required for DS0 FC collocation the CLEC should use the 02QB9.005 NCI code. See Figures 2-4, 2-5, and 2-6 for FC Collocation splitter arrangements.

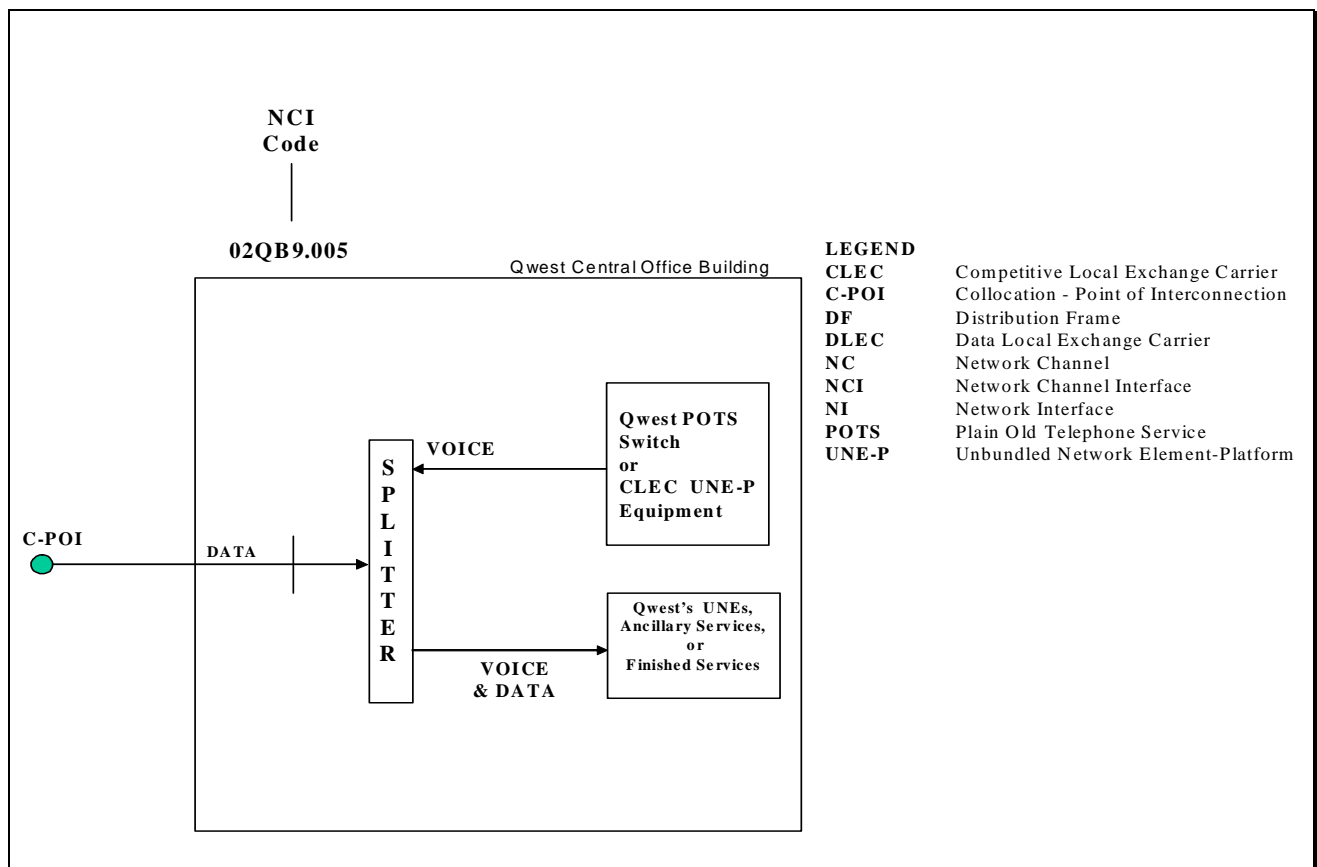

Figure 2-4 DS0 FC Collocation, Example 1

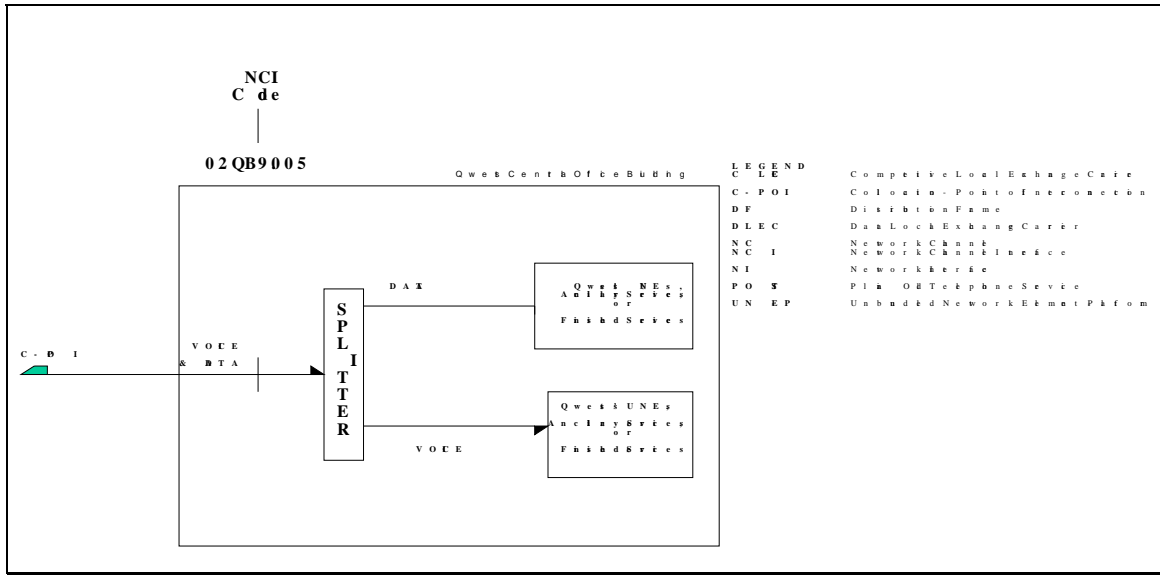

Figure 2-5 DS0 FC Collocation, Example 2

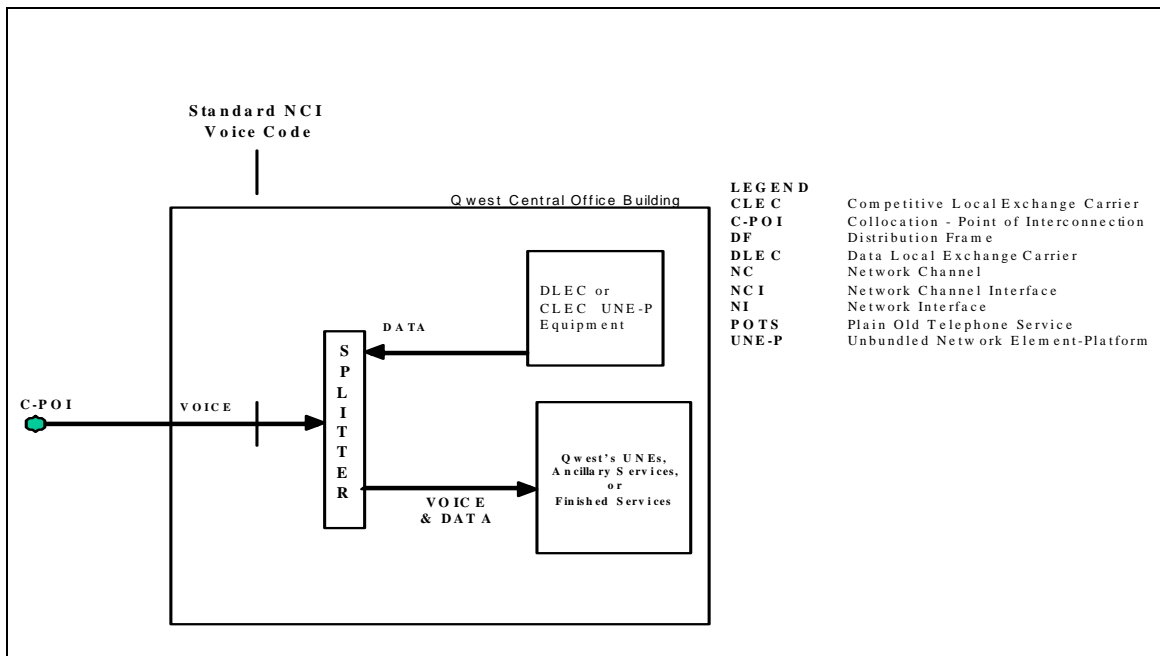

Figure 2-6 DS0 FC Collocation, Example 3

2.8.1.2 FC Collocation is available at the Digital Service Level 1 (DS1) UNE services. If utilized for DS1 UNEs, you must transmit a Trunk Level 1 (T1) templated signal over the copper facility. DS1 Copper entrance facilities will be wired to a DS1 office repeater, or other comparable CO equipment, to remove line voltage before terminating on the DSX panel. Standard DS1 NC and NCI codes should be used.

NOTE: In order to reduce cross-talk noise produced by T1s, the T1 pairs should be assigned to different binder groups whenever possible, as specified by ANSI standard T1.417, *Spectrum Management for Loop Transmission Systems*.

A T1 span repeater may be required at the C-POI to control T1 signal levels and cross talk. In addition the CLEC will need to provide the following information to Qwest to insure the overall integrity of the DS1 FC Collocation circuit.

- Length of cable between the Point of Interconnection (C-POI) and the CLEC's closest T1 span repeater or equivalent unit
- Cable insertion loss from the CLEC's closest T1 span repeater or the equivalent unit and the C-POI.
- Cable Gauge.
- Power setting of the CLEC's closest T1 span repeater and if applicable any LBO attenuation added to the circuit at this T1 span repeater.
- Whether the cable is screened or shielded. If neither, are the transmit and receive pairs in separate cables? If not, what is the binder group and pair information? T1 transmit and receive pairs should be separated and/or shielded from one another, per ANSI standard T1.417, *Spectrum Management for Loop Transmission Systems*
- Total simplex resistance of the circuit on the CLEC's side of the C-POI.

2.8.1.3 DS1 FC Collocation design considerations

The following is a summary of guidelines that Qwest follows, but is not limited to. It is strongly recommended that CLEC's also follow these guidelines to ensure the overall integrity of the DS1 FC Collo. circuit.

- Binder group separation should be maintained at all times to mitigate the effects of self near-end crosstalk. Per Telcordia document [BR 901-600-130 Digital Line Engineering Program \(DILEP\)](#), DILEP calculations should always be done to ensure proper spacing of the repeater housings. If binder group separation is not possible, then adjacent separation is permissible. However, spacing of repeaters is reduced under these circumstances. Same binder group (non-separation of transmit and receive pairs) reduces efficiency of

the T1 circuit. In addition, future T1 pairs combined in the same non-separated binder may bring down the T1 services. This type of design should be avoided.

- The insertion loss from the Qwest CO office repeater shelf to the first OSP field T1 span repeater should not be less than a minimum of 9.2 dB nor exceed a maximum of 22.5 dB. If the cable insertion loss is less than 9.2 dB, then LBO attenuation needs to be added to the circuit. If the insertion loss exceeds 22.5 dB, then another T1 span repeater may need to be added to the circuit (note: adding an additional T1 span repeater may require LBO attenuation).
- The insertion loss of the intermediate T1 span repeater sections shall not exceed 32.5 dB.
- The design of the T1 repeater section at the End Users span , also known as the customer end section, is limited to a loss between 0 and 16.5 dB, including connector loss.
- All DS1 signal levels within the same cable binder at the POI need to be within 7.5 dB of each other. This is a spectrum management requirement designed to reduce the amount of cross talk noise.
- Outside plant facilities must be conditioned by the removal of **all** bridged taps, load coils, inductors and build out capacitors.

NOTE: All bridge tap must be trimmed out of the T1 design. There is no tolerance for any bridge tap in the design of a T1 circuit.
- Total Simplex Resistance (TSR) shall not exceed 4333 ohms.
- Apparatus cases should be placed at all junctions, such as Serving Area Interfaces, to ensure signal levels are equal in both transmission paths

Protection from lightning or voltage is required for copper entrance facilities and will require protection units on standard connector blocks on the distribution frame. Qwest will engineer and install this protection as part of the CLECs FC collocation request. All copper cables used for interconnection or access to UNEs, Ancillary Services, or Finished Services must come through a cable vault/entrance facility and have grounded/bonded sheaths, per technical publication 77355, *Grounding - Central Office and Remote Equipment Environment*.

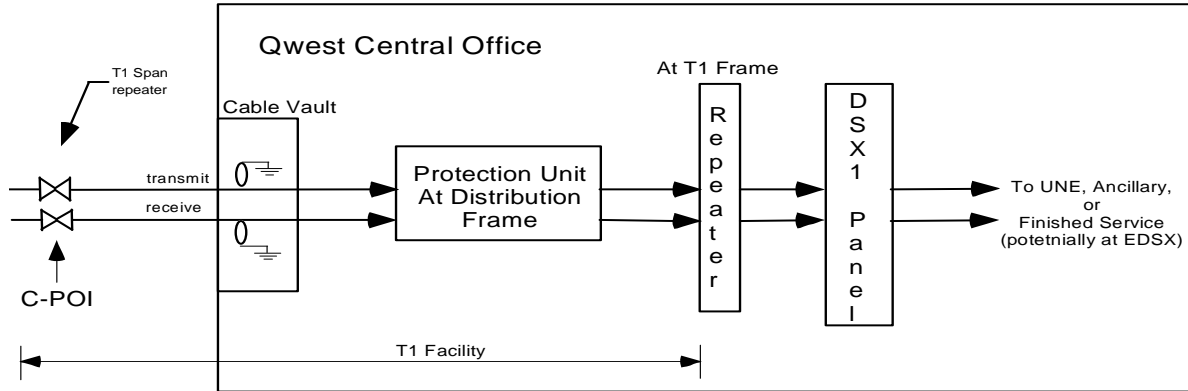

Figure 2-7 Typical DS1 FC Collocation example.

2.8.2 Fiber Entrance Facility for FC Collocation

FC Collocation is available at the Fiber Entrance Facility level for termination and cross-connection to appropriate fiber UNEs

2.8.3 Non-Standard FC Collocation Entrance Facility

Other levels of FC Collocation service such as Digital Service Level 3 (DS3) or DS1 utilizing fiber are available via the Bona Fide Request collocation order process.

2.9 Equipment and Wiring Requirements

The Interconnector will normally have collocated equipment located in the Qwest wire center. This equipment is called *Interconnector Designated Equipment* or IDE. This equipment and the associated wiring must meet various safety and regulatory requirements including local building codes. These standards include several Qwest technical publications listed in Section 1.6. Chapter 4 discusses some additional requirements specific to different types of Collocation.

The following types of equipment may be placed in collocated space include:

- SONET Terminals mapped to DS1 or asynchronous DS3.
- Asynchronous Optical Line Terminating Equipment and Multiplexers.
- Microwave Terminal Equipment.
- Channel banks or functional equivalent.
- Terminal blocks and cross-connect frames or panels.
- Any other equipment needed to terminate basic transmission facilities.
- Remote switch modules and Asynchronous Transfer Mode (ATM) switches.

Equipment shall be of a type normally found in a wire center. This is to assure compatibility with the Central Office end of the appropriate service channels.

IDE located in a Qwest wire center under any type of collocation (Chapter 4) are required to comply with GR-63-CORE, *Network Equipment-Building System* (NEBS) Level 1 safety standards and with GR-1089, *Electromagnetic Compatibility and Electrical Safety – Generic Criteria*, requirements, for level 1 compliance.

In addition, Qwest requires CLECs that utilize Cageless (Sections 4.5) types of collocation within a Qwest wire center must also comply with NEBS level 2 and 3 earthquake Zone 2 and 4 requirements.

Interconnectors may not place DC power plants as IDE. DC power is available from Qwest. This requirement is for safety (e.g., OSHA and Hazardous Material) and floor-loading requirements. Qwest's DC power plant is located in an area of the wire center designed for that purpose and to meet various safety standards.

Inter-bay cabling between adjacent bays is permitted only if designed for direct cabling. Otherwise, inter-bay cabling must be placed in the cable racks. See the publications listed in Section 1.6 for further information.

The following features will be available in conjunction with collocation:

- DC Power. See Chapter 4 for additional information.
- Composite or DS1 Clock (optional feature) where available. Clock (i.e., synchronization) is required for Digital Data Service and 56/64 kbit/s Frame Relay connections. Clock may be needed for other situations. See Chapter 13 for further details.

See the appropriate tariff, catalog or contract for further information.

CONTENTS

Chapter and Section	Page
3. Interconnection Arrangements	3-1
3.1 Typical Wire Center Arrangement	3-1
3.2 Interconnection Arrangements	3-4
3.2.1 Basic Requirements for Interconnection	3-4
3.2.2 DS0 or Voice Level Needs	3-6
3.2.3 DS1 Level Needs	3-7
3.2.4 DS3 Level Needs	3-8
3.2.5 Fiber or Optical Level Needs	3-8
3.3 InterConnection Distribution Frame (ICDF) Frame	3-9
3.3.1 General Description	3-9
3.3.2 DS0/Voice ICDF	3-10
3.3.3 DS1 and DS3 ICDFs	3-13
3.3.4 Fiber ICDF	3-15
3.3.5 Usage	3-16
3.4 Network Interface Options	3-17
3.4.1 Standard ICDF Arrangement	3-18
3.4.2 Direct Connection - Point of Termination Arrangement	3-20
3.4.3 Combinations of Arrangements	3-24
3.5 Tie Cables, Frames and Terminations	3-24
3.5.1 General Requirements	3-24
3.5.2 ICDF Arrangement	3-27
3.5.3 Direct Connection - POT Arrangement; Qwest Supplied	3-28
3.5.4 Direct Connection - POT Arrangement; CLEC Supplied	3-28
3.6 Combination of UNEs on Different "Design-To" Frames	3-29
3.7 Comparison of Interconnection Arrangements	3-29
3.9 Direct Connection Between Entrance Facilities and UNEs	3-32

CONTENTS (Continued)

Figures	Page
3-1 Typical Wire Center Arrangement.....	3-2
3-2 Typical Network Interface Arrangement.....	3-5
3-3 Generic DS0/Voice Interconnection Arrangement.....	3-11
3-4 DS0/Voice ICDF Arrangement.....	3-12
3-5 Typical DS1 or DS3 ICDF Arrangement.....	3-14
3-6 DS1/DS3 Signal Flow Between IDE and UNE.....	3-15
3-7 Fiber ICDF Arrangement.....	3-16
3-8 Typical Standard ICDF Arrangement.....	3-19
3-9 Typical Direct Connection - POT Arrangement.....	3-21
3-10 Another Direct Connection-POT Arrangement.....	3-23

Tables

3-1 Comparison of ICDF and Direct Connection - POT Arrangements.....	3-30
--	------

3. Interconnection Arrangements

This chapter describes the Interconnection arrangements available with Qwest and provides the Certified Local Exchange Carrier (CLEC) with information to aid in selecting the appropriate type of Interconnection in a wire center.

Each arrangement carries different features and levels of responsibility for the CLEC.

The CLEC needs to understand how Qwest functionally arranges the typical wire center to be able to choose an arrangement and then design their network.

Information in this chapter is generic. Qwest will provide information about a specific wire center when the CLEC decides to interconnect in the wire center. This information will enable the CLEC to place Interconnector Designated Equipment (IDE), order appropriate cables and frame terminations, and take other preliminary steps in the process of interconnecting and collocating in a Qwest wire center.

Once the CLEC installs equipment, it can order Unbundled Network Elements (UNEs) or Finished Services.

3.1 Typical Wire Center Arrangement

Figure 3-1 illustrates a typical Qwest Wire Center. IDE that is owned by two different CLECs is shown. A number of cross-connect frames and equipment are also illustrated.

The figure also lists some of the types of UNEs that may appear on each frame.

There are four basic categories or levels of equipment and cross-connect frames that may be encountered in the wire center. They include DS0 or Voice, DS1, DS3, and fiber or optical levels.

The DS0 or Voice levels are connected to the Common System Main Interconnecting (COSMIC®) Frame, Main Distribution Frame (MDF) or Intermediate Distribution Frame (IDF). The typical wire center will have an IDF(s) and either a COSMIC® or a MDF frame(s).

The DS1 and DS3 levels connect to the DSX-1 and DSX-3 frames respectively.

Fiber or optical connections are made at the Fiber Distribution Panel (FDP) or Fiber Distribution Frame.

The Qwest UNEs are connected to these cross-connect frames.

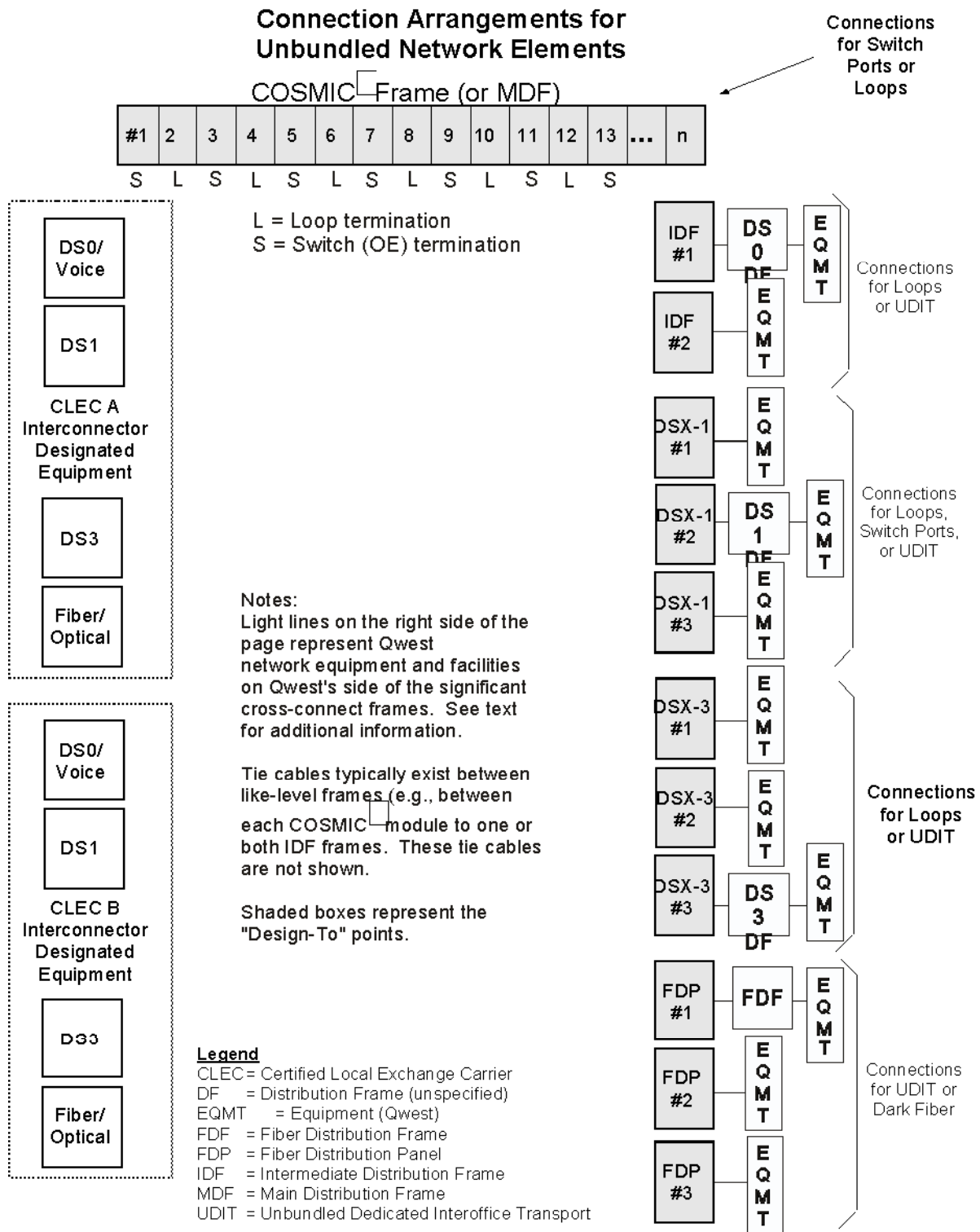

Figure 3-1 Typical Wire Center Arrangement

Other frames may occur in some wire centers. The frame names may also vary. The generic name *IDF*, for example, may appear in several forms including Toll Distributing Frame (TMDF), Trunk Distributing Frame (TMDF), etc. This publication assumes that the illustrated types of frames exist. Any different frames must be similarly treated. Some background information and requirements about the frames may be found in TR-EOP-000161, *Modular Distributing Frame System*, and TR-EOP-000163, *Modular Distributing Frame Framework*. Qwest may not follow these Technical References all of the time, but they do provide a basic understanding of the situation.

The quantity of each type of frame varies by wire center. The quantities in Figure 3-1 are for illustrative purposes only. The larger wire centers have more of each type of frames. One exception is the COSMIC[®] frame. Normally, there will only be one COSMIC[®] frame in a wire center unless space limitations have forced a multiple frame arrangement. However, COSMIC[®] frames will have different numbers of modules.

The CLEC using collocation must connect their IDE to the appropriate cross-connect frame. A CLEC may also wish to connect two UNEs together, with or without their own IDE included.

The cross-connect frames designated with shaded boxes in Figure 3-1 are called “Design-To” points in this publication. This name comes from the fact that the CLEC must “Design-To” these frames even if they are not the Network Interface (NI) with Qwest. This approach provides greater flexibility and minimizes costs and design problems. Further information about the “Design-To” point may be found later in this chapter and in Chapter 5.

Figure 3-1 does not show tie cables going between different frames at the same level. At the DS1 level, for example, tie cables normally connect the three illustrated DSX-1 frames together to allow the connection of equipment on one DSX-1 frame to equipment on another DSX-1 frame.

The situation at the DS0/voice level is significantly more complex. The design of the COSMIC[®] frame requires that any connections to it be spread across the frame to each module. Thus, a tie cable must be placed from one or both of the illustrated IDF frames to each module on the COSMIC[®] frame. In the situation where such tie cables are placed to only one of the IDF frames, the two IDF frames would have tie cables between them. Thus, connections between the COSMIC[®] frame and the unconnected IDF are routed via the other IDF. This is discussed in more detail in Section 3.2.2.

3.2 Interconnection Arrangements

There are some basic requirements for a CLEC to interconnect with Qwest UNEs at a NI. There are several arrangements available to meet these requirements. Availability depends on space availability, contracts and regulatory orders. The NI is not the same with these arrangements. The arrangements will also have different processes and responsibilities.

3.2.1 Basic Requirements for Interconnection

Channels on each level (DS0 or Voice, DS1, DS3, and fiber or optical) are segregated from those on other levels. Figure 3-2 illustrates how IDE is connected to UNEs. This figure assumes that the "Design-To" point cross-connect frames and the NIs are two different cross-connect frames. This is not always the case. The Network Interface Cross-Connect Frames are functionally IDFs. The NI frame (or equivalent) may be located either in or outside the collocation space. The frame may be provided by the CLEC if located inside their space. Figure 3-1 also applies. However, there will also be situations where the two frame functions are provided on the same frame. Tie cables will not be required in this situation.

The arrangement will vary from wire center to wire center and may vary over time in a specific wire center. The arrangement will depend on frame space and the availability of floor space for frame growth.

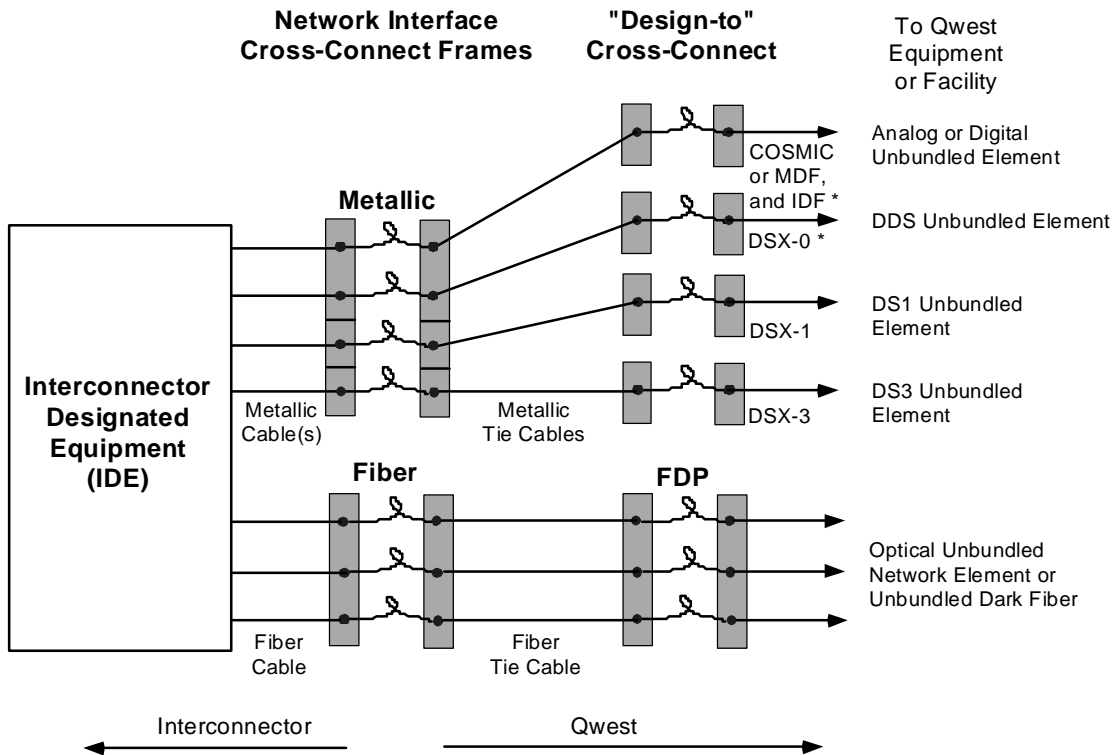

- DDS = Digital Data Service (Qwest)
- FDP = Fiber Distribution Panel (or frame)
- IDF = Intermediate Distribution Frame
- MDF = Main Distribution Frame
- COSMIC = Central Office System Modular InterConnect

* The IDF and DSX-0 may be the same cross-connect and may carry another name.

Figure 3-2 Typical Network Interface Arrangement

The NI cross-connect frame will frequently be used by Qwest in the provisioning of other services for retail customers if the frame is not located inside the CLEC's collocation space.

The UNEs will be delivered to a NI located at a Point of Termination (POT). The POT will be located either:

- 1) On the Standard (shared) InterConnection Distribution Frame (ICDF) or
- 2) On a DC-POT in the CLEC's collocation area.
- 3) On a DC-POT outside the CLEC's collocation area on a DSX.

The CLEC must indicate which of the options they wish when they fill out the Collocation Order Form.

3.2.2 DS0 or Voice Level Needs

As previously mentioned, UNEs at the DS0 or Voice level are connected to the COSMIC®, MDF, TMDF or IDF cross-connect frame(s). The connections will be made using cables and/or tie cables depending on the arrangement. Typical UNEs that appear at these "Design-To" cross-connect frames include the Unbundled Analog Line Switch Ports, several types of Unbundled Loops and some Unbundled Dedicated Interoffice Transport (UDIT) applications.

All cable additions to a COSMIC® frame require a Mechanized Engineering Layout for Distributing Frames (MELD) automated termination program computer run. A MELD run provides distributing frame configuration and termination location data to be used to update the database used for mechanized administration of the frames involved. The information includes frame system configurations, frame configurations, and termination records for switch ports, cable pairs and tie pairs.

Tie cables must be placed on modules of the COSMIC® frame based on the MELD run. The COSMIC® frame concept is based on using short jumpers to minimize frame congestion. In optimal circumstances, jumpers should be placed no further than adjacent modules. Modules exist for switch Originating Equipment (OE) and outside plant loop terminations.

CLECs may choose to connect to an IDF frame rather than the COSMIC® frame. This will reduce costs to the CLEC and avoid delays by not having to have a MELD run and then connecting to each module. It then becomes Qwest's responsibility to do the MELD run and place any tie cables between the IDF and the COSMIC® frame.

Similar arrangements must be made in wire centers using a MDF in place of a COSMIC® frame. However, the jumper restrictions on an MDF are not nearly as restrictive. MELD runs are not required for MDF or any of the various types of IDF frames including TMDF frames.

Tie cables will also have to be placed to the IDF(s) if any DS0 UDIT, DS1 multiplexer or any other UNEs with circuit conditioning equipment are required. Some Unbundled Loops, for example, may use circuit-conditioning equipment.

A few wire centers may have a separate DSX-0 cross-connect frame for DS0 level digital cross-connects. This normally occurs only with Digital Data Service (DDS) applications. This function is usually included on the IDF rather than a separate DSX-0 frame. However, tie cables will have to be placed to the separate DSX-0 frame if the CLEC needs to connect to UNEs of this type that appear there.

Tie cables to these DS0 or Voice frames are placed in multiples of 100 pairs. The cables are normally 26 gauge.

3.2.3 DS1 Level Needs

DS1 level channels are connected to a DSX-1 cross-connect frame. Since a wire center will often have multiple DSX-1 frame lineups for “Design-To” points, tie cables will have to be placed to each lineup if the CLEC needs to get to the specific DSX-1 frame. Several UNEs are connected to this “Design-To” point including the DS1 Message Trunk Port, the DS1 capable Unbundled Loop, and several UDIT applications.

The arrangement and related requirements will vary in different wire centers. This is because of the size and location of frames plus the availability of spare termination space at a specific location on the frame.

A situation could occur, for example, where a single centrally located tie cable frame termination could reach the entire DSX lineup and still be within the 85-foot limit. However, if no spare termination space exists on the frame at this central location, multiple tie cables might have to be placed at less centralized locations to reach the entire frame.

Qwest will advise the CLEC as to such arrangements.

Tie cables for DS1 applications are placed in multiples of two 28-pair shielded cables (i.e., 56 pairs). Separate cables are used for transmit and receive. Each pair of cables has a capacity of 28 DS1 systems.

3.2.4 DS3 Level Needs

The situation for DS3 is similar to DS1. DS3 channels must connect to the DSX-3 cross-connect frame. The DSX-3 frame serves as the “Design-To” point. Since a wire center will often have multiple DSX-3 frames, tie cables will have to be placed to each lineup if the CLEC needs to get to the specific DSX-3 frame.

As with the DSX-1 situation, spare terminations may not always be available in the optimal frame locations. The arrangement will vary in different wire centers.

Qwest will advise the CLEC as to such arrangements.

Tie cables for the DS3 level are available in multiples of a pair (transmit and receive) of coaxial cables. Each pair of coaxial cables has a capacity of one (1) DS3 system.

3.2.5 Fiber or Optical Level Needs

Fiber or optical channels must be connected to a Fiber Distribution Panel (FDP) or frame. Since a wire center will often have multiple FDPs, cables will have to be placed to each if the CLEC needs to get to the specific FDP.

The “Design-To” point concept does not have the same impact at the fiber or optical level. This is because optical spans are designed from optical transmitter (e.g., LASER) to receiver (detector). Since Qwest will normally be providing only a part of this span, some joint engineering will probably be required to successfully design these connections.

Fiber tie cables, if required, are available in multiples of twelve (12) fibers.

3.3 InterConnection Distribution Frame (ICDF) Frame

As one of three options, a collocator may choose to use a cross-connect frame called an InterConnection Distribution Frame (ICDF) as the Network Interface in Figure 3-2.

3.3.1 General Description

The ICDF does not have mixed bandwidth terminations. That is, DS0 or Voice, DS1, DS3, and fiber or optical terminations are normally not mixed together in the same ICDF. The precise arrangement may vary in different wire centers.

The ICDF is functionally located between the IDE and any Qwest “Design-To” cross-connect frames. The CLEC side (i.e., the “vertical” side) of the ICDF is connected to the IDE by cables. The Qwest side (i.e., the “horizontal” side) of the ICDF is connected to various other “Design-To” cross-connect frames (and thus to the UNEs) by tie cables. The terms “vertical” and “horizontal” only have meaning on DS0/voice cross-connect frames, but the terms will be used in this document with other frames to indicate the IDE or UNE termination side.

The ICDF and the “Design-To” cross-connect frames may be the same frame in many wire centers. The CLEC must know which arrangement (i.e., the same or different frames) applies in a specific wire center to correctly design their services.

While the ICDF serves as a NI between the CLEC and Qwest for many collocators, it also serves the function of an IDF in the network being assembled by the CLEC.

The ICDF cross-connect frame is:

- A trouble isolation and testing point
- A NI between an Interconnector and Qwest
- A cross-connect between Interconnectors
- A type of distributing frame
- Flexible to meet changing requirements
- A termination for CLEC Facilities

The ICDF cross-connect frame is **not**:

- A one-for-one tie termination point
- An add-on to overloaded cross-connect facilities

The ICDF cross-connect frame at DS1 and DS3 levels will be a DSX cross-connect with a templated signal only if the ICDF is also the “Design-To cross-connect frame. In cases where the two are different frames, the ICDF **WILL NOT** be a DSX with a templated signal.

The Fiber ICDF serves these functions for the fiber and optical level connections. See Chapter 12 for additional information not in this chapter.

Qwest will notify the CLEC as to the ICDF terminations and the CLEC will supply jumpers (except as noted) and maintain records for their future use.

3.3.2 DS0/Voice ICDF

Figure 3-3 illustrates a generic arrangement for DS0/voice connections. Figure 3-4 illustrates a pictorial arrangement of the DS0/Voice ICDF arrangement.

Tie cables from Qwest UNEs are tied down to the horizontal side of the ICDF. Cables from the IDE are connected to the vertical side. These frames will be identified by normal COMMON LANGUAGE® designations. Qwest will provide the CLEC with the frame addresses and cable designations.

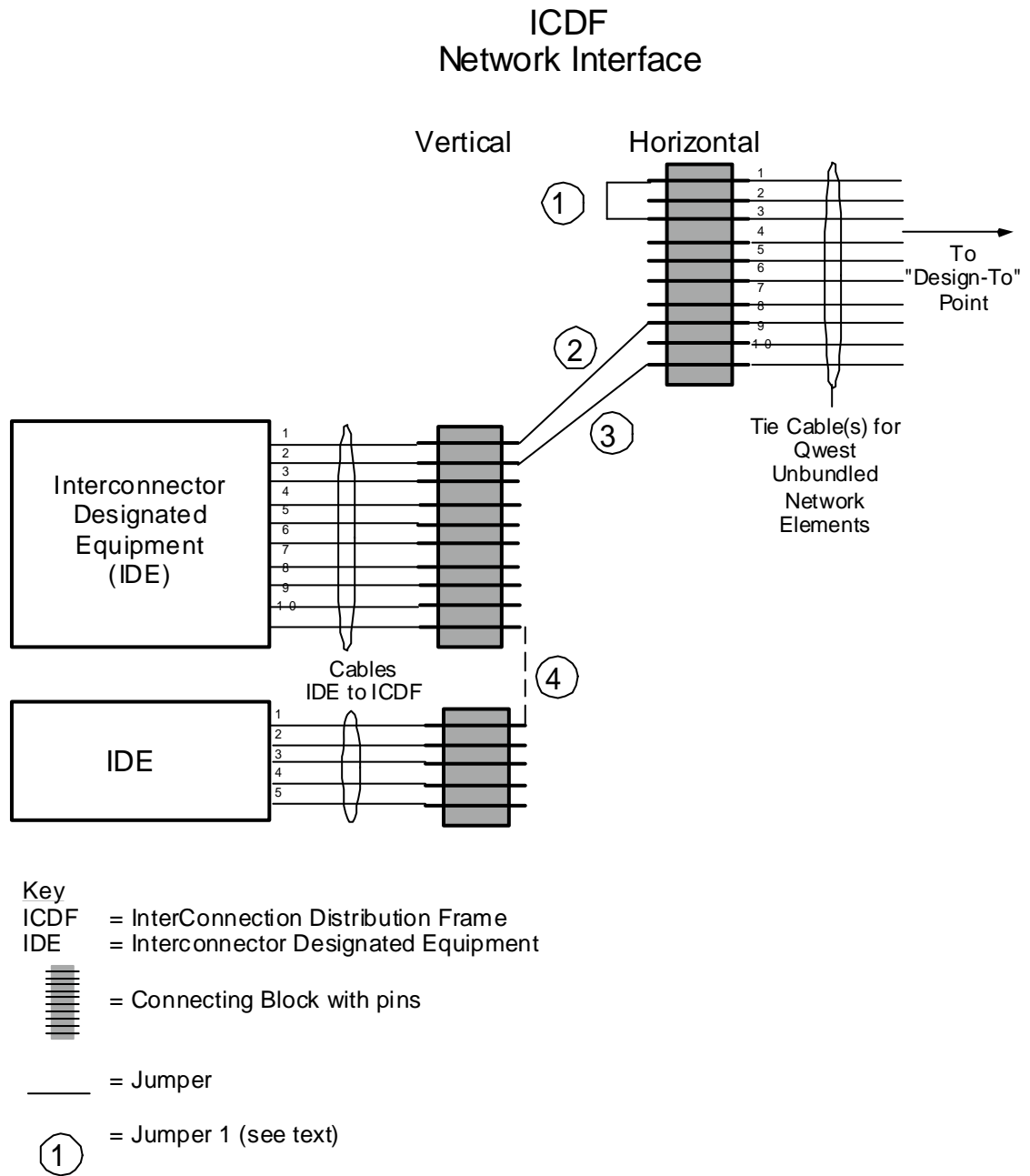
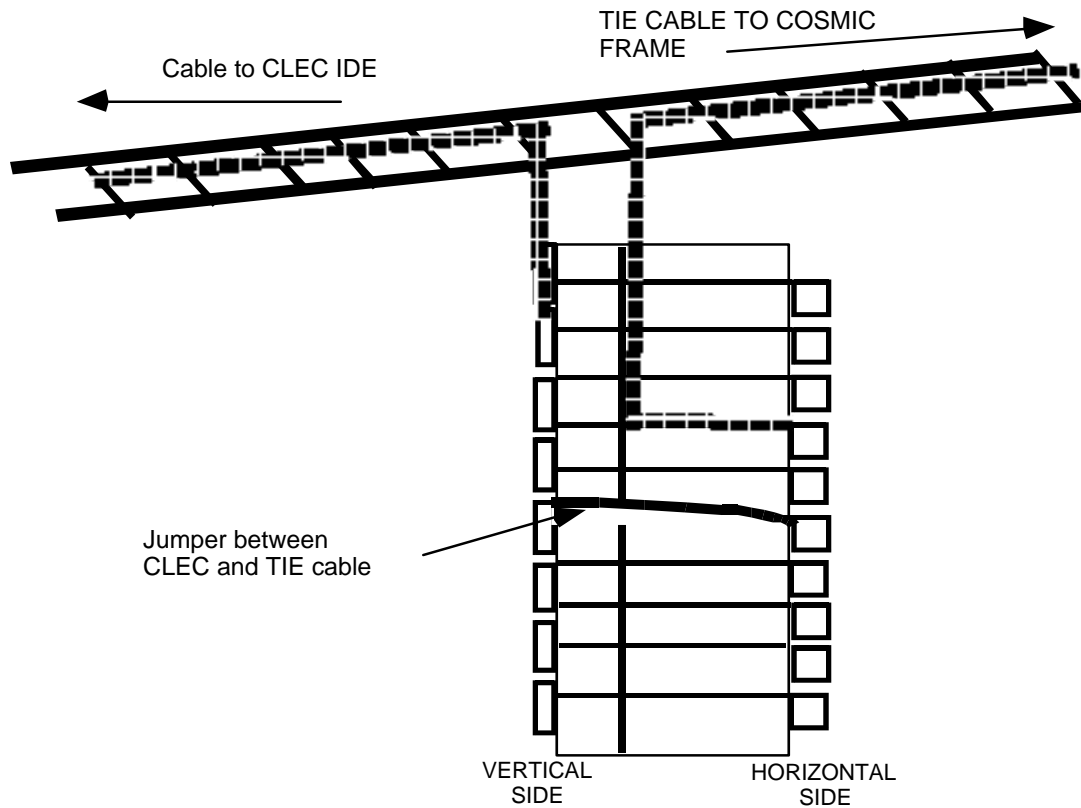

Figure 3-3 Generic DS0/Voice Interconnection Arrangement



End view of InterConnection Distribution Frame (ICDF) showing typical CLEC cable termination, a jumper between the horizontal and vertical side, and a typical tie cable termination.

Figure 3-4 DS0/Voice ICDF Arrangement

Arrangements where the ICDF is a COSMIC® frame, the cables from the IDE must be installed based on the MELD run described in Section 3.2.2. Cables must be placed in multiples of 100 pairs **to each module** based on the MELD run.

Arrangements where the ICDF is another type of frame (IDF, MDF, TMDF, etc.), a MELD run is not required and IDF to ICDF cables in 100 pair multiples are required. This arrangement reduces the quantity of IDF to ICDF pairs and eliminates the delay and cost of obtaining a MELD run. Tie cables (and the associated MELD run) from the IDF to a COSMIC® frame under this arrangement become the responsibility of Qwest.

Jumpers are placed on the frame in order to provide service to the CLEC's customers. **The CLEC must maintain records of these connections.**

Four such connections are illustrated in Figure 3-3. Jumper 3 connects Pair 2 from the IDE to Pair 10 of the tie cable. Similarly, Jumper 2 connects Pair 1 from the IDE to Pair 8 of the tie cable.

Such connections could be used, for example, to tie a CLEC switch to an Unbundled Loop Element to provide a standard Plain Old Telephone Service (POTS) line to the CLEC customer. The connections from the CLEC switch would be transported to the Qwest wire center on transport facilities (not shown) and terminated on the IDE via an Entrance Facility (not shown). The Unbundled Loop Element (not shown) would be connected to the tie cables on the right side of the figure.

The jumper identified by "1" illustrates another application in which no IDE is involved. For example, if tie pair #1 was connected to a Qwest Unbundled Switch Port Element and tie pair #3 was connected to an Unbundled Loop Element, placing the jumper would result in the connection of the Unbundled Switch Port Element to the Unbundled Loop Element. This would result in a POTS line to the CLEC customer.

The jumpers identified by "4" illustrate a similar arrangement for CLEC-to-CLEC connections.

Further information about the combination of UNEs may be found in Appendix A.

The Interconnector may either provide the cable from the IDE to the vertical side of the ICDF or order the cable from Qwest. Qwest will terminate the cable(s) on the ICDF. The Interconnector is responsible for the inventory of the vertical side while Qwest is responsible for the inventory of the horizontal side.

3.3.3 DS1 and DS3 ICDFs

Many of the basic concepts for the DS1 and DS3 arrangements are the same as the DS0/voice arrangement.

Typical DS1 or DS3 ICDF lineups will alternate bays for termination of tie cables with bays for termination of collocated IDE cables. Figure 3-5 illustrates one form of a three-bay arrangement. With the illustrated arrangement, the three-bay set would be replicated as required to meet the CLEC's needs. Other arrangements may exist.

The illustration shows an example of a UNE. The UNE tie pair appears on pin “n” of the center “horizontal” bay. Qwest will notify the CLEC that the UNE appears on pin “2” of the vertical bay.

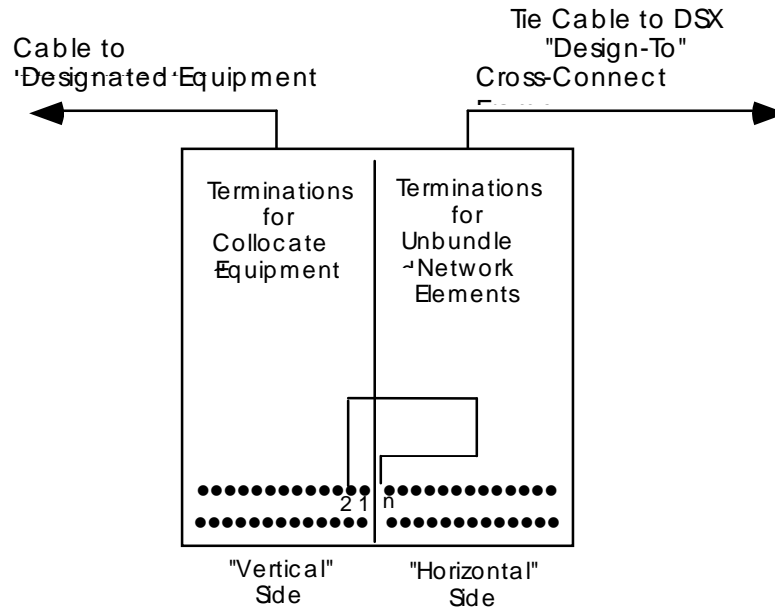

Figure 3-5 Typical DS1 or DS3 ICDF Arrangement

In the situation where the ICDF and the “Design-To” frame are the same, the figure would be modified. The CLEC would also be notified of the location of the UNE.

Figure 3-6 is a wiring diagram that illustrates the signal flow from the CLEC IDE connected to a Qwest-provided UNE. Note the reversals required to connect the Transmit from the Qwest equipment to the Receive of the IDE.

The Digital Distribution Point (DDP) on the "vertical" frame is a termination shelf providing testing, monitoring, turn up and cross-connect capabilities. This function may be provided by similar equipment with a different name.

In the situation where the ICDF and the "Design-To" frame are the same, the figure would be modified to eliminate the standalone ICDF. The wiring to the IDE would now connect to jacks "0" and "1" on the combined DSX/ICDF. The double reversal on the standalone ICDF with jumpers would be eliminated.

DS1/DS3 Signal Flow

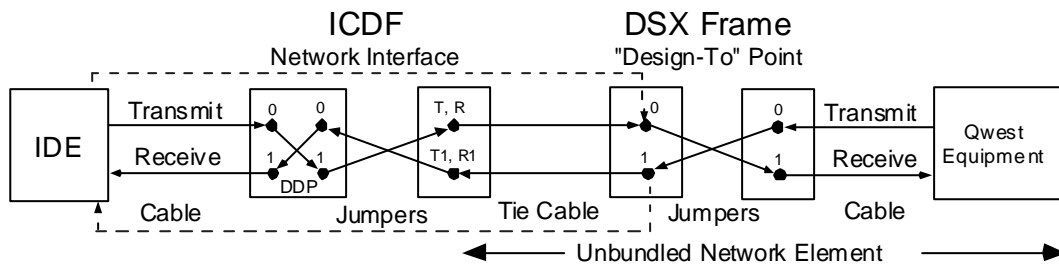

- Key**
 DDP = Digital Distribution Point
 ICDF = InterConnection Distribution Frame
 IDE = Interconnector Designated Equipment
 T = Tip
 R = Ring

Arrows denote signal flow.
 Numbers denote terminations
 Dashed lines denote if ICDF and DSX are same frame

Figure 3-6 DS1/DS3 Signal Flow Between IDE and UNE

3.3.4 Fiber ICDF

Terminations on the Fiber ICDF may be ordered in multiples of twelve fiber terminations. Each panel, with capacity for twelve fiber terminations, may be physically protected to limit access to the CLEC. The cables to IDE and tie cables from Qwest terminate on the rear of different panels. Jumpers, provided by the CLEC, are used to connect the IDE to the tie cables as illustrated in Figure 3-7.

Further information about interconnection of fiber and optical channels at the Fiber ICDF may be found in Chapter 12.

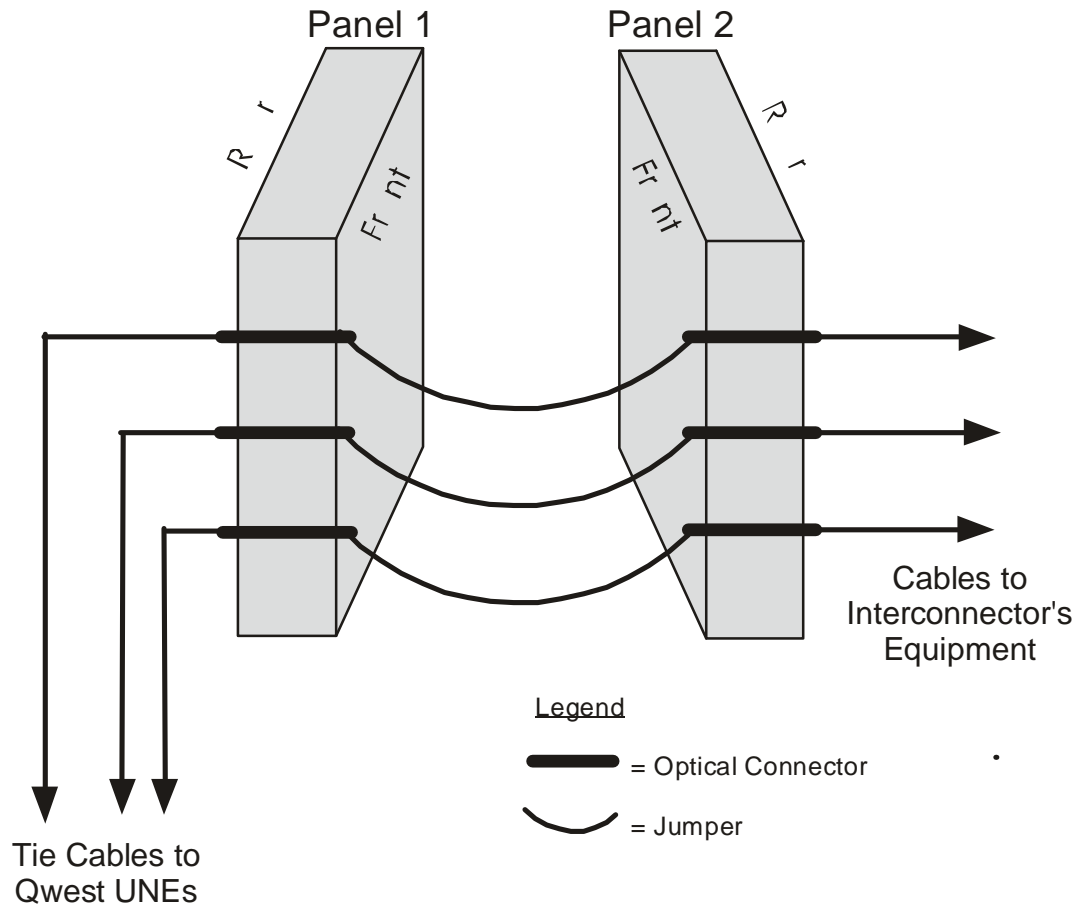

Figure 3-7: Fiber ICDF Arrangement

3.3.5 Usage

As previously mentioned, the ICDF is sectionalized into DS0/Voice, DS1, DS3, and fiber or optical sections. The DS1 and DS3 sections are designed for use in connecting DS1 and DS3 channels respectively. They should be designed to meet the DSX panel at the "Design-To" point with a templated signal. Thus, the channels must not be powered carrier system spans such as a T1-carrier system. The carrier systems should be terminated in office repeaters and only the DS1 or DS3 signal passed on to the appropriate ICDF.

Similar comments apply in wire centers where there is a separate Digital Data Service (DDS) DSX-0 cross-connect panel or frame. In this instance, the signals are limited to the DSX-0 signal generated by a DS0-DP channel unit or the equivalent. Applications using OCU-DP channel units should be routed through the Voice section of the “Design-To” cross-connect and tie cables. However most Qwest wire centers will not have separate DSX-0 cross-connect frames and use the same frame for both analog and digital DS0 or voice signals.

The DS0 or Voice section of the ICDF is to be used for DS0 level digital or voice signals. This section may also be used for other acceptable signals above the DS0 level as long as there are no interference or safety problems. The tie cables are standard unshielded cables. The restriction against powered T1-Carrier spans applies here also. This is because the pairs are not shielded, binder group separation is not assured, and the high voltages present safety hazards on the frame.

Certain systems such as the digital subscriber loop technologies (e.g., High-bit-rate Digital Subscriber Line or HDSL) may be placed in the DS0/Voice section. However, these must be identified to Qwest so that insulating caps may be placed on the cross-connect pins to protect technicians working on or near the cross-connect frames. Notification should be done by using appropriate Network Channel and Network Channel Interface codes.

3.4 Network Interface Options

There are three possible locations for an NI between the collocated IDE and the “Design-To” cross-connect frames. The collocator should choose the NI location. The availability of NIs in a wire center will depend upon space availability, contract and regulatory order.

NI alternatives differ especially concerning the tie cables between the IDE and the various “Design-To” cross-connect frames.

These NI alternatives are:

1. A standard (shared) ICDF
2. A cross-connect frame or block assigned to a single CLEC for the purpose of a direct connection between the CLEC’s space and the “Design-To” frames.
 - a. on the collocator’s floorspace
 - b. on an existing cross-connect that terminates similar Qwest retail services

3.4.1 Standard ICDF Arrangement

The standard ICDF Arrangement has a single set of ICDFs shared by multiple CLECs in the wire center. The standard ICDF, also known as a Common or Shared ICDF, will be referred to as an ICDF in this document. The ICDFs may also be used by Qwest to provision services for other customers. Separate ICDFs are provided for the four digital signal levels if needed in a specific wire center. The ICDF for the specific level is identified when a CLEC first requests the need for terminations at that level. Additions are placed as required. The actual ordering process is beyond the scope of this publication. The ICDF will have to be identified (if not already identified) and ICDF terminations will have to be ordered and installed before any UNEs may be ordered.

A typical wire center using the standard ICDF arrangement is illustrated in Figure 3-8. This figure is a variation of Figure 3-1. The shaded boxes represent the ICDFs.

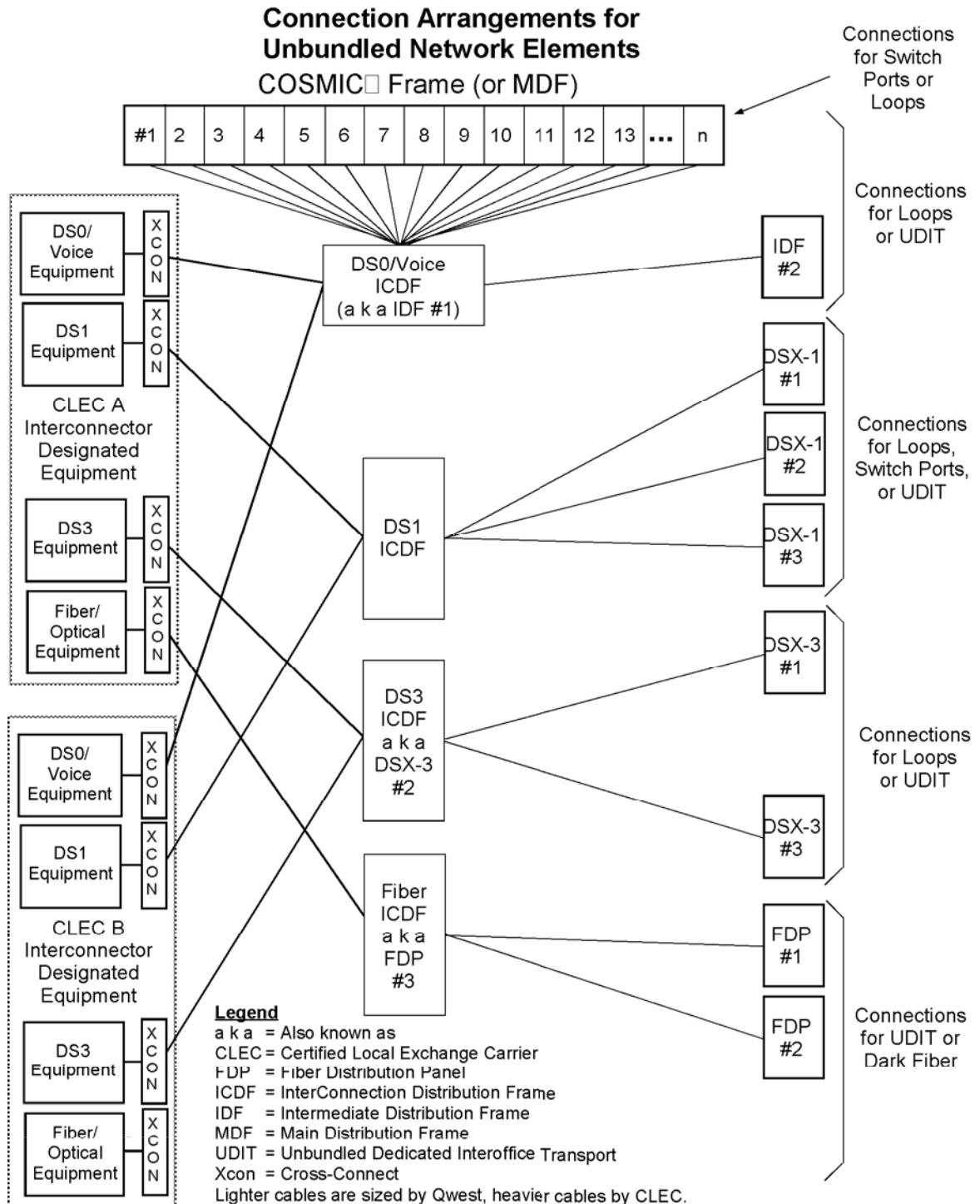

Figure 3-8 Typical Standard ICDF Arrangement

The #1 IDF frame has been designated as the DS0/Voice ICDF. The IDF could also be known as a TMDF in this wire center. Since the CLEC does not cable directly to the COSMIC[®] frame, the CLEC does not have to worry about MELD runs, etc. as discussed in Section 3.3.2.

At the DS1 level, an old Single Point of Termination frame was designated as the ICDF. The three DSX-1 frames serve as “Design-To” points. (Qwest is no longer installing Single Point of Termination frames.)

The #2 DSX-3 was designated as the DS3 ICDF. This frame is both ICDF and “Design-To” Point.

The FDP #3 was designated as the Fiber ICDF.

The arrangements in other wire centers could be different.

The CLEC has the responsibility to size and maintain records for the cables from their IDE to the ICDF (vertical side) at each level as discussed in Section 2.7.

Qwest places tie cables from each ICDF (horizontal side) to the various “Design-To” cross-connect frames at each level. The CLEC orders terminations on the ICDFs to meet their needs. These terminations are ordered as a part of an order for a UNE. No separate order is required. In this example, CLEC B has determined that they do not need access to fiber or optical UNEs.

Qwest has the responsibility of sizing the tie cables from the ICDF to each “Design-To” frame. This will be done partly based on the information provided by the CLEC. Qwest will maintain records of these tie cables. Further information about the tie cables and terminations and related responsibilities may be found in Section 3.5.

3.4.2 Direct Connection - Point of Termination Arrangement

A Direct connection - Point of Termination (DC-POT) is a cross-connect frame, block or panel that serves as a NI or demarcation point. This arrangement is sometimes called a *Direct (Dedicated) Connection*. A typical arrangement is illustrated in Figure 3-9. The shaded boxes are the DC-POT frames.

Since the DC-POT is assigned to a single CLEC, the CLEC has the added responsibility to determine which “Design-To” frames with which they need to connect. This can be determined in a meeting or on a tour. The CLEC must then size the tie cables to these frames. The CLEC must do this design work and then order the DC-POTs and tie cables from Qwest. The frames, terminations and tie cables must be in place prior to ordering any UNEs. With the DC-POT, the termination order will not be a part of the UNE order since the tie cables and terminations must be in place prior to ordering UNEs.

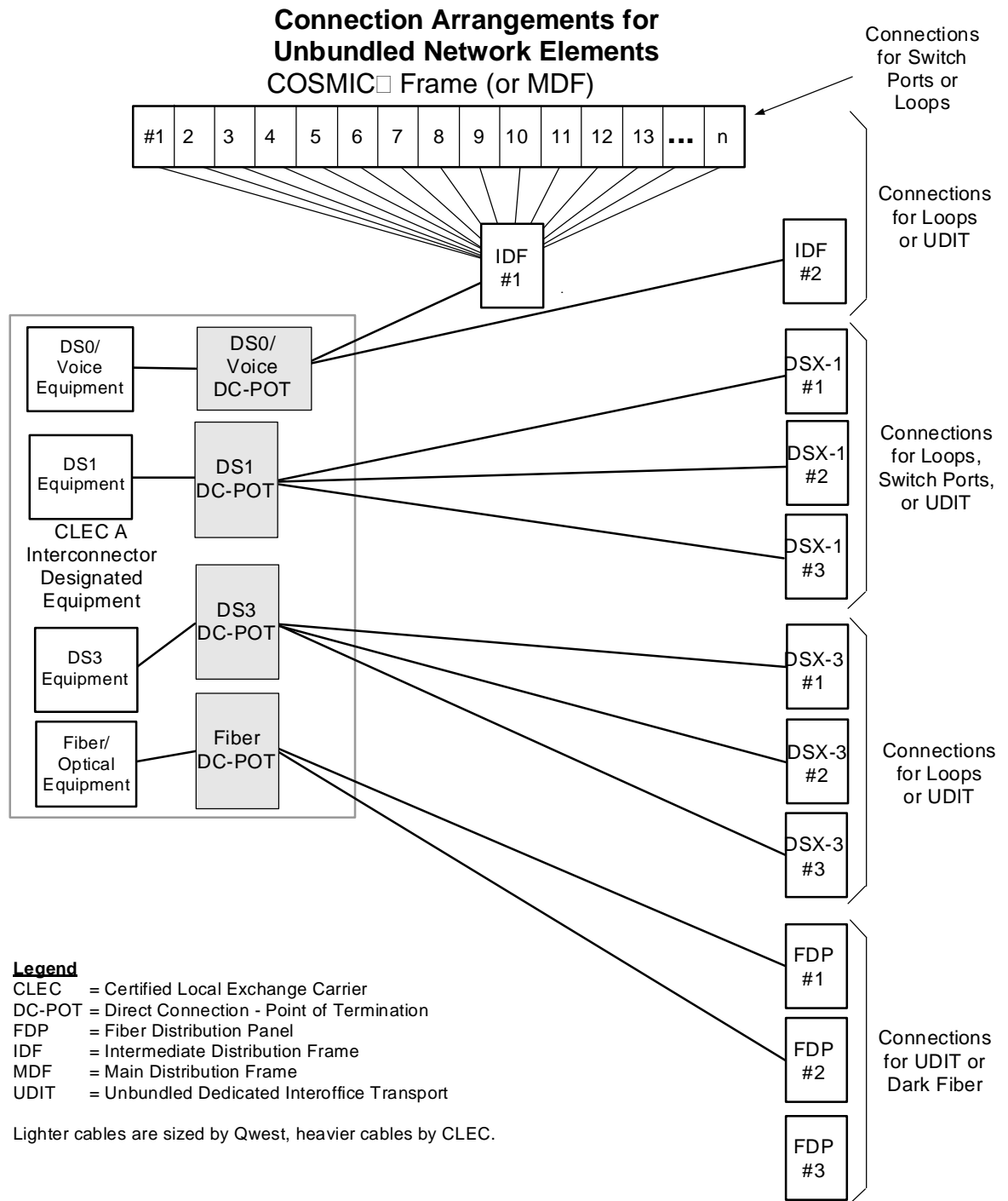

Figure 3-9 Typical Direct Connection - POT Arrangement

“Design-To” frames are the frames to which Qwest connects their equipment. In the case of Direct Connection, it is guaranteed that there is no intervening cross-connect frame.

In this example, the CLEC has determined that they do not need access to FDP #3. Should this change in the future, the CLEC must order the tie cable(s) before any UNEs to that frame may be ordered.

In this example, the CLEC also opted to cable the DS0/voice DC-POT to IDF #1 and avoid the extra cost and delay for a MELD run required when connecting to a COSMIC® frame. Figure 3-10 illustrates the same arrangement with cabling direct to the COSMIC® frame.

Further information about the tie cables, terminations and related responsibilities may be found in Section 3.5.

The DC-POT may be located inside the CLEC’s space. In this arrangement, the added security of locked doors or panels may be omitted. Under this option, the CLEC must provide access to their enclosure to test circuits from the DC-POT if required

The CLEC may opt to provide the DC-POT. The CLEC may also negotiate with Qwest and order a non-standard DC-POT from Qwest. Further descriptive information in this chapter about the DC-POT may not apply in either case.

Alternatively, the DC-POT may also be located outside the collocation space on the same frame that terminates similar Qwest retail services.

When requested, Qwest will provision the collocation terminations directly to an existing frame, bypassing the ICDF.

The different types of DC-POTs are described as follows:

DS0/Voice Direct Connection - POT

The basic Qwest-provided DS0/Voice DC-POT is an enclosed single-sided low-profile frame with front access only. The frame is equipped with a two-vertical unit with terminations for 800 pairs for IDE and 800 pairs for tie cables connected to UNEs. Qwest and the CLEC will both have keys to the doors enclosing the front of the frame. The Qwest key and door will permit access to the “horizontal” (top) part of the frame only. The CLEC key will give access to the entire frame.

Horizontal DC-POT tie cables are available in 100 pair multiples. Thus, up to eight different “Design-To” frames or COSMIC® modules may be connected to the DC-POT. A Meld run is required in the latter application as discussed in Section 3.2.2.

A CLEC requiring access to more frames or modules will have to order more DC-POTs.

CLECs wishing direct connection (i.e., cabled directly to) the COSMIC® frame are limited to using these cables for 2-wire POTS. Services requiring electronic equipment must be cabled to an IDF.

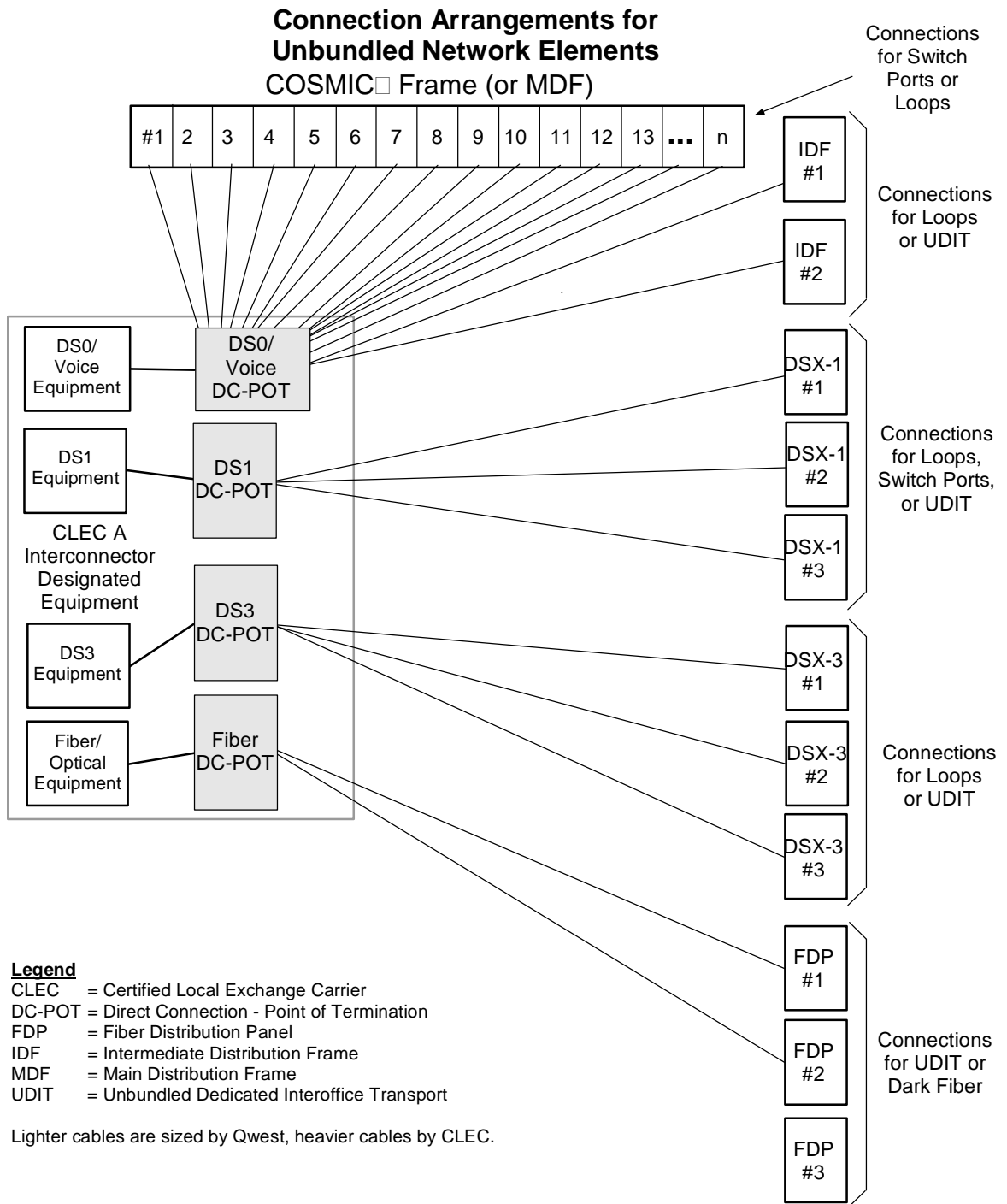

Figure 3-10 Another Direct Connection-POT Arrangement

DS1 Direct Connection - POT

“Horizontal” DC-POT tie pairs for DS1 are available in multiples of two 28-pair shielded cables (transmit and receive) with a capacity of 28 DS1 circuits. Different tie cables may connect to different “Design-To” DSX-1 frames.

A cabinet, lockable panel or other arrangement will be provided to limit access to the cross-connect panels, if requested, for installations outside a cage.

The Qwest-provided DS1 DC-POT is a composite bay with terminations for 512 DS1 circuits for IDE and 512 DS1 circuits for tie pairs to DS1 UNEs.

DSX-1 and DSX-3 panels may be located on the same physical frame.

DS3 Direct Connection - POT

“Horizontal” DC-POT tie pairs for DS3 are available in multiples of two (2) coaxial cables (transmit and receive) with a capacity of one (1) DS3 circuit. The tie cables may connect to different “Design-To” DSX-3 frames.

A cabinet, lockable panel or other arrangement will be provided to limit access to the cross-connect panels, if requested, for installations outside a cage.

The Qwest-provided DS3 DC-POT is a composite bay with terminations for 128 DS3 circuits of IDE and 128 DS3 circuits for tie pairs to DS3 UNEs.

DSX-1 and DSX-3 panels may be located on the same physical frame.

Fiber Direct Connection - POT

The Fiber DC-POT has terminations for multiples of 12 fibers. The twelve-fiber termination panel on the Qwest-provided Fiber DC-POT may be protected with a lock to provide additional security. See Section 3.3.4 for further information.

3.4.3 Combinations of Arrangements

Combinations of arrangements may be permitted. For example, the DC-POT could be used in the collocation space at the DS0/voice level while an ICDF arrangement could be used at the DS1 level and a DC-POT outside collocation space could be used at the DS3 level.

3.5 Tie Cables, Frames and Terminations

3.5.1 General Requirements

Terminations on the ICDF or DC-POT can be ordered in multiples depending on the type of termination and the Interconnection arrangement.

Horizontal terminations are used to connect to UNEs. Vertical terminations are used to connect to IDE.

Qwest will provide the CLEC with the cross-connect frame arrangement in a specific wire center at the time the CLEC arranges for the collocation of equipment or identifies the need for ICDF terminations.

Qwest will provide the CLEC the ICDF or DC-POT termination addresses and tie cable identification.

All pairs in cables from IDE and tie cables must be terminated on the ICDFs or DC-POTs. Termination of cable pairs at the IDE end of these cables is at the option of the CLEC.

ANSI T1.102-1994, *Digital Hierarchy - Electrical Interfaces*, may be consulted for further information.

The CLEC may wish to use small tags on jumpers placed on the ICDF to identify ownership and circuit ID. This may help reduce any problems related to the mis-identification of the jumpers. Qwest does use these small tags on fiber jumpers and some other limited applications with good success in reducing errors.

The CLEC must order terminations on the ICDF or DC-POT as described in the following sections.

The CLEC must order the appropriate frame terminations prior to ordering any UNEs!

Qwest will supply standard jumper wire for DS0 and DS1 jumpers. However, the CLEC has the option of providing the CLEC's own wires. The CLEC must either provide their own DS3 and fiber jumpers or order them from Qwest.

3.5.2 ICDF Arrangement

The CLEC must order appropriate ICDF terminations in the wire center to meet their needs. The CLEC must identify the vertical terminations as connected to cable going to IDE (Figure 3-3).

Qwest will install the terminations on the ICDF and the tie cables between the horizontal side of the ICDF and the "Design-To" frames based on information provided by the CLEC (assuming the two functions are not on the same frame). Qwest has the responsibility to size the tie cables and determining which "Design-To" frames need to be accessed. Qwest is responsible to monitor usage on the tie cables and to place additional tie cables in a timely manner. The CLEC has responsibility to notify Qwest of any changes in their anticipated usage (i.e., a forecast).

The CLEC must size and provide the cables between their IDE and the vertical side of the ICDF. The CLEC may also order these cables from Qwest when the collocation order is placed. Qwest will terminate the pairs on the ICDF.

The CLEC must administer and keep records for the IDE to ICDF cables. Qwest must administer and keep records for the tie cables (if any) between the ICDF and "Design-To" frames.

Terminations for DS0 or voice applications on the vertical side of the DS0/Voice ICDF can be obtained in multiples of 100 pair terminations (100 pairs of tie cables). All cable pairs must be terminated on the ICDF.

Qwest has responsibility for ordering and implementing the MELD run required for any COSMIC® frames.

ICDF terminations for DS1 applications will be available with capacity for multiples of 28 DS1 systems (two 28-pair shielded tie cables, transmit and receive).

Terminations for DS3 and above can be obtained in multiples of one system. Specifically, the DS3 tie cables would consist of two coaxial cables (transmit and receive) per system.

Fiber terminations and tie cables will be in multiples of two fibers (transmit and receive). Cables to IDE will be in multiples of twelve fibers.

3.5.3 Direct Connection - POT Arrangement; Qwest Supplied

The CLEC must size and provide the cables between their IDE and the vertical side of the DC-POT. These cables must meet the requirements of the publications listed in Section 1.6. The CLEC may also order the cables from Qwest. Qwest will terminate the pairs on the vertical side of the Qwest-provided DC-POT.

The CLEC will also order DC-POT terminations and tie cables between the horizontal side of the DC-POT and the other cross-connect frames identified as the "Design-To" point (the DC-POT can be the "Designed To" frame point). This involves determining which "Design-To" frames they need to access and then sizing the tie cables to these frames.

These tie cables must go directly from the DC-POT to the "Design-To" frames and may not be routed through the standard (shared) ICDF unless requested by the CLEC.

Qwest will install the DC-POT and terminate the tie cables on the horizontal side of the DC-POT and "Design-To" frames as ordered by the CLEC.

Descriptive information in the following sections may not apply if the CLEC orders a non-standard DC-POT from Qwest.

DS0/Voice DC-POT

The standard Qwest-provided DS0/Voice DC-POT has a capacity of 800 "vertical" terminations to connect to IDE and 800 "horizontal" terminations to connect to tie cables for UNEs.

Tie cables from the DS0/Voice ICDF to each IDF or MDF frame or module on a COSMIC® frame can be obtained in multiples of 100 pairs.

Qwest has responsibility to order the MELD run for any COSMIC® frame additions. The MELD run will be based on the pair requirements ordered by the CLEC.

DS1 DC-POT

DC-POT terminations for DS1 applications will be available with capacity for 512 systems (1024 shielded pairs) each for both "horizontal" and "vertical" sides of the standard Qwest-provided frame.

The tie pairs to each DSX-1 "Design-To" frame are available with a capacity of 28 DS1 systems (two 28-pair shielded cables, transmit and receive). Cables from DC-POT to IDE are available in the same sizes.

DS3 DC-POT

DC-POT terminations for DS3 applications will be available with capacity for 128 systems (256 coaxial cables) each for both “horizontal” and “vertical” sides of the standard Qwest-provided frame.

Tie cables to the DSX-3 “Design-To” frames and cables to IDE for DS3 can be obtained in multiples of a one-system capacity. Specifically, these DS3 cables would consist of two coaxial cables (transmit and receive) per system.

Fiber DC-POT

The Fiber ICDF and standard Fiber DC-POT are usually the same type of frame. See Section 3.5.2 for further information.

3.5.4 Direct Connection - POT Arrangement; CLEC Supplied

The CLEC may provide the DC-POT. Under these circumstances, the DC-POT would normally be placed inside the CLEC’s enclosure. The CLEC may alternatively lease floor space outside the enclosure (Cageless Physical Collocation).

CLEC-provided DC-POTs may be sized to meet the CLEC’s needs. However, tie cable multiples do not change. These tie cables must go directly from the DC-POT to the “Design-To” frames (the DC-POT can be the “Design-To” frame point) and may not be routed through the standard (shared) ICDF unless requested by the CLEC.

Cables between a CLEC-provided DC-POT and their IDE must be provided by the CLEC.

3.6 Combination of UNEs on Different “Design-To” Frames

There are some special issues related to ICDF Collocation. ICDF Collocation involves the CLEC ordering UNEs and then connecting them together without any IDE. Chapter 4 provides further information about ICDF Collocation. Appendix B also discusses the combination of UNEs.

The CLEC may combine UNEs together at the ICDF or DC-POT. Tie cables will connect the “Design-To” frames to the ICDF or DC-POTs.

3.7 Comparison of Interconnection Arrangements

There are two main differences between the standard (shared) ICDF and the DC-POT arrangements.

First, the DC-POT arrangement provides improved security for the CLEC in that the frames are dedicated for their use and may be in lockable enclosures. Access to the standard ICDF arrangement is not restricted.

The second main difference is that for the DC-POT arrangement, the CLEC takes the added responsibility of identifying and sizing all tie cables required. This function must

be done from the DC-POT directly to the various "Design-To" cross-connect frames and for the DC-POT to IDE cables.

Qwest will provide the CLEC with information as to the type and identification of the "Design-To" cross-connect frames in a specific wire center. These typically include COSMIC® and/or MDF, IDF, DSX-1, DSX-3, FDP and sometimes other types of frames.

Table 3-1 summarizes the arrangements.

Since the tie cables will be dedicated to the CLEC, the minimum quantities have changed for DS1 and above frames to fill out a panel on the DC-POT.

Table 3-1 Comparison of ICDF and Direct Connection - POT Arrangements

Item or Responsibility		Standard ICDF	Direct Connection - POT
Orders frame terminations		CLEC	CLEC
Responsible for sizing and ordering tie or NI cables to all necessary "Design-To" cross-connect frames		Qwest ** (Tie Cables)	CLEC (Tie cables)
Installs tie cables		Qwest	Qwest
Basic size for cables (or multiples of)	DS0/Voice	100 pairs	100 pairs
	DS1	28 circuits (56 pr)	28 circuits (56 pairs)
	DS3	1 circuit (2 coax cables)	1 circuit (2 coax cables)
	Fiber	12 fibers	12 fibers
Terminations on ICDF, or DC-POT	DS0/Voice	100 pair multiples vertical, 1 pair multiple horizontal	800 pairs each side *
	DS1	28 circuits (56 pairs) vertical, 1 circuit (2 pairs) horizontal	512 circuits (1024 pairs) each side *
	DS3	1 circuit (2 coax cables)	128 circuits (256 coax cables) each side *
	Fiber	12 fibers	12 fibers *
Size and "Design-To" termination point of tie (ICDF/DC-POT) or IDE (No ICDF) cables.	DS0/Voice	Qwest determines size and "Design-To" termination point, CLEC not impacted.	100 pair multiples per COSMIC® module and/or 100 pair multiples per MDF or IDF. CLEC determines termination point.
	DS1		28 DS1 circuit (56 pair) multiples per DSX-1 lineup. CLEC determines termination point.
	DS3		1 DS3 circuit (2 Coaxial cables) multiples per DSX-3 lineup. CLEC determines termination point.
	Fiber		2 fiber multiples. CLEC determines termination point.
Lockable enclosure for ICDF		No	Yes (No if inside an enclosure) *
CLEC Responsibility		Lowest	Middle
CLEC Flexibility		Highest	Middle

* May not apply to non-standard DC-POT or if DC-POT is provided by the CLEC.

** See Section 4.6 for special considerations with ICDF Collocation.

Qwest will place the cable(s) provided by the CLECs for the direct cable option. Any such cable must meet appropriate fire and safety standards including, but not limited to, the Network Equipment - Building Systems (NEBS) Level 1 safety standards, (FR-2063), National Electric Code (NEC), Occupational Safety and Health Administration (OSHA) and various federal, state and local regulations.

As an alternative to having Qwest place the cable(s), the CLEC may use a Qwest-approved installation vendor to place the cable in the identified route. Qwest must terminate any cable at a Virtual Collocation site.

New cable racks may be shared with others or dedicated for the CLEC's sole use. If the cable rack is dedicated, it must be labeled with the CLEC's name.

3.9 Direct Connection Between Entrance Facilities and UNEs

There may be situations when a CLEC desires to directly connect their entrance facility to UNEs. This arrangement is available only when permitted by tariff, contract or regulatory order.

This arrangement is more likely to occur when using a Metallic Pair Entrance Facility (Section 2.7.3), but may occur with other types of entrance facility. In these situations, there is no need for any collocated IDE.

Microwave Entrance Facilities (Section 2.7.5) and using a Finished Service instead of an entrance facility (Section 2.7.6) are excluded from this situation.

The entrance facilities requirements are discussed in Chapter 2.

4. Types of Collocation

4.1 General

There are eight basic types of Collocation available: Virtual Collocation, Caged Physical Collocation, Shared Caged Physical Collocation, Cageless Physical Collocation, InterConnection Distribution Frame (ICDF) Collocation, Adjacent Collocation, Common Area Splitter Collocation, Remote Collocation. No distinction will be made between the type of collocation in this publication unless there are specific differences.

The primary difference between Virtual and Physical Collocation is who installs and maintains the IDE. QWEST provides this function for Virtual Collocation while the Competitive Local Exchange Carrier (CLEC) provides the function for Physical Collocation.

QWEST will work with a CLEC if they wish to change types of collocation.

The layout and location of equipment in the wire center varies with the type of Collocation.

QWEST will normally provide power to a collocated CLEC on redundant primary and secondary DC feeds (i.e., a total of four wires) based on power drain values provided by the CLEC. Some additional details are provided later in this chapter.

Essential AC Power, with potential short interruptions in case of a commercial power failure, may be available for Physical Collocation dependent on QWEST capacity and availability. Essential AC power is AC that is backed up by a standby engine-generator.

PUB 77385 should be consulted for further information.

The physical or virtual space must be labeled with the CLEC's name, COMMON LANGUAGE[®] Location Identification (CLLI[™]) code, and an emergency telephone number.

CLEC may collocate any equipment that is necessary for interconnection or access to unbundled network elements (UNEs) such as DSLAMS, ATMs, or packet switching. Remote Switching Units (RSUs) also meet this legal standard when used for Interconnection or access to unbundled network elements for purposes of providing Local Exchange Service Interconnection (Reference FCC Collocation Remand Order, FCC 01-204 in the advanced services docket, 98-147).

NOTE: Before any type of CLEC switching equipment is collocated, the CLEC must provide to Qwest an inventory of the associated equipment and how it is intended to be used for Interconnection or access to Unbundled Network Elements.

Qwest will also provide a connection between unbundled network elements and ancillary services and a demarcation point. Such connection is an Interconnection Tie Pair (ITP). The demarcation point shall be:

1. at CLEC-provided cross-connection equipment located in CLEC's Virtual or Physical Collocation Space; or
2. if CLEC elects to use ICDF Collocation, at the Interconnection Distribution Frame (ICDF); or
3. if CLEC elects to use an ICDF in association with Virtual or Physical Collocation, at the ICDF;
4. at a direct connection point of termination as described below
5. at another demarcation point mutually-agreed to by the Parties.

4.2 Virtual Collocation

4.2.1 General

The term "Virtual Expanded Interconnection-Collocation" (VEIC) denotes an arrangement whereby an Interconnector's fiber optic (or other) facilities are connected at a Collocation Point of Interconnection (CPOI) to QWEST-owned fiber optic entrance facilities. The CPOI is designated by QWEST and is located outside of a QWEST wire center. The entrance facilities are connected to Interconnector owned basic transmission terminating equipment installed and maintained by QWEST or its representative. Chapter 2 provides additional information on the CPOI and entrance facilities.

The Interconnector provides the basic equipment known as Interconnector Designated Equipment (IDE) and QWEST installs and maintains the equipment.

QWEST will install, maintain and repair equipment dedicated to Interconnector's use under the intervals negotiated with the Interconnector.

The Interconnector will be able to designate the IDE dedicated to their use. They will also be able to monitor and control their circuits terminating in the QWEST wire center.

IDE associated with this offering and located in the QWEST wire center will be installed, maintained and repaired by QWEST.

The Interconnector is responsible for obtaining and providing to QWEST any administrative codes (e.g., COMMON LANGUAGE[®] codes) for all IDE.

In addition to the IDE, the Interconnector shall provide the following:

- A specification of all software options for the IDE and associated plug-ins,

- All necessary connecting and/or jumper cables (e.g., frame-to-frame or shelf-to-shelf),
- All unique tools and test equipment for IDE,
- Initial and subsequently added equipment sized and equipped to handle a minimum of twelve (12) months forecasted growth,
- Any necessary equipment for remote monitoring and control,
- All necessary plug-ins and/or circuit packs.

CLEC's virtually collocated equipment must comply with Bellcore Network Equipment Building System (NEBS) Level 1 safety standards and any statutory (local, state or federal) and/or regulatory requirements in effect at the time of equipment installation or that subsequently become effective. CLEC shall provide Qwest interface specifications (e.g., electrical, functional, physical and software) of CLEC's virtual collocated equipment. Such safety and engineering standards shall apply to CLEC equipment only to the degree that they apply to Qwest equipment located in Qwest's Premises.

The Interconnector is responsible to ensure functionality between different vendors SONET IDE.

See the appropriate tariff, catalog or contract for further information.

There are some differences in Virtual Collocation depending on if it is ordered from a tariff or a contract.

4.2.2 Virtual Collocation Ordered from a Tariff

Virtual Collocation may be ordered from Section 21 of Tariff FCC #1. The tariff should be consulted for further information. Otherwise, the standards defined in this publication apply.

4.2.3 Virtual Collocation Ordered from a Contract

Virtual Collocation ordered from a contract is defined in this publication except as noted in the contract.

4.3 Caged Physical Collocation

Physical Collocation denotes an arrangement whereby an Interconnector's fiber optic (or other) facilities are connected at a CPOI to Interconnector-owned fiber optic Entrance Facility, which extends via a QWEST-provided Entrance Facility, to their physical space. The CPOI is designated by QWEST and is located outside of a QWEST wire center.

Caged Physical Collocation -- allows CLEC to lease caged floor space for placement of its equipment within Qwest's Premises for the purpose of interconnecting with Qwest finished services or accessing unbundled elements. CLEC is responsible for the

procurement, installation and on-going maintenance of its equipment as well as the cross connections required within the cage.

The Interconnector will install and maintain their IDE.

Where available, central office floor space typically in multiples of 100 square feet may be obtained by CLECs for the purpose of placing their IDE for interconnection to QWEST Unbundled Network Elements (UNEs) or Finished Services. Space in non-standard sizes will be permitted under some circumstances. The shape of this

space will be determined by QWEST with input from the CLEC. The space will be enclosed.

Caged Physical Collocation will be provided by QWEST as outlined in the appropriate tariff, catalog or contract.

Appropriate equipment and fire protection standards (including NEBS, NEC, OSHA, state and local requirements) must be met. The Interconnector bays or cabinets must meet all equipment installation technical standards as specified in PUBs 77350, 77351 and 77355. The Interconnector will have design and equipment maintenance responsibilities.

The CLEC must provide access to QWEST if required for test and turnup of the Entrance Facility.

General requirements for power and grounding installation of Physical Collocation are covered in PUB 77350 and Chapter 8 of PUB 77385. Of special concern is that only one set of primary and secondary feeds can be connected per collocator fuse panel. Parallel fusing is prohibited by NEC Article 240-8.

4.4 Shared Caged Physical Collocation

Normal Physical (caged) collocation space may be shared if the original CLEC agrees to allow a second CLEC to share their caged space. Under Shared Physical Collocation, one CLEC obtains a Caged Physical Collocation arrangement from Qwest pursuant to this Agreement or an approved interconnection agreement, and another CLEC, pursuant to the terms of its agreement or approved interconnection agreement, may share use of that space, in accordance to terms and conditions of a sublease agreement between the two CLECs. The original CLEC must provide QWEST with a signed Letter of Authorization.

Qwest shall make Shared Collocation space available in single-bay increments or their equivalent.

Each CLEC's IDE will have its own COMMON LANGUAGE™ Location Identification (CLLI). Requests for terminations to the appropriate NI with QWEST must be unique to each CLEC in the shared space.

4.5 Cageless Physical Collocation

Cageless Physical Collocation describes a Physical Collocation arrangement where IDE bays are available one bay at a time rather than the standard 100 square feet arrangement.

QWEST will attempt to group similar types of equipment together. Multiple-bay requirements will be located in adjacent bays whenever possible.

Currently the minimum square footage in Qwest central office buildings is nine (9) square feet per bay. However, if smaller bays are or become available, Qwest will reduce the minimum square footage accordingly.

Normal 2-foot rear and 3-foot front clear spacing will be provided for access whenever possible. Newer arrangements may have a 2.5-foot rear space. These aisles are for the common use of all people in the wire center to access their equipment.

The CLEC is responsible for providing and installing the bays using a QWEST-approved installation vendor.

Alternatively, the CLEC may have QWEST order and install the Equipment Bay framework, which will also include anchor bolts, top support, extenders and spacers, for the CLECs Cageless collocation. The CLEC is still responsible for procurement, installation and maintenance of all the equipment within the bay and any cross connections required within the leased collocation space. Upon completion of the Collocation site, the CLEC assumes ownership of the Equipment Bay and is responsible for removal of the bay in the event of Decommissioning of the site.

Note: This option is available on the New/Change/ Augment form.

The bay must be clearly labeled for CLEC ownership per QWEST direction.

Qwest will supply -48 volt DC power fused at 125% of the required amperage per bay via a Battery Distribution Fuse Board (BDFB) or a main distribution Power Board (PBD).

CLEC must identify what equipment will be installed and the vendor technical specifications of such equipment so that Qwest may verify the appropriate power, floor loading, heat release, environmental particulate level, HVAC, and tie cables to CLEC-provided cross-connection device.

The equipment installed must meet Qwest's adopted NEBS Level 1 safety standards as discussed in Section 2.8. Other criteria will apply as described in the publications listed in Section 1.6.

Convenience outlets will be available in every third bay or nearby walls or columns. Outlets will not be placed in the bottom of the equipment bay unless nearby outlets are not available.

Information in this and other Technical Publications concerning physical collocation will also apply to Shared Collocation unless otherwise stated.

4.6 InterConnection Distribution Frame (ICDF) Collocation

4.6.1 General ICDF Collocation

ICDF Collocation applies when the CLEC has no IDE collocated in the QWEST wire center. The CLEC would select this type of collocation when they wish to establish a presence for the purpose of combining UNEs, Ancillary and Finished Services without having any collocated equipment.

The only presence required of the CLEC in the wire center are the horizontal and vertical (or equivalent) terminations on the appropriate NI cross-connect frame as described in Chapter 3.

Terminations are available in 100 DS0/voice pairs, one (1) DS1 systems, one (1) DS3 system or one (1) fiber pair. These terminations must be ordered using the normal Collocation Order Form.

4.6.2 CLEC-to-CLEC Cross Connections

CLEC-to-CLEC Cross Connections allow for a CLEC who desires interconnection with another CLEC within the same ILEC central office building for the mutual exchange of traffic, and allows the CLECs to more efficiently provide service.

Qwest shall design and engineer the most efficient route and cable racking for the connection between CLEC's equipment in its collocated spaces to the collocated equipment of another CLEC located in the same Qwest Wire Center building. CLEC shall have access to the designated route and construct such connection, using copper, coax or optical fiber equipment utilizing an Qwest-approved vendor or another vendor of CLEC's own choosing, subject to Qwest's approval, which may not be unreasonably withheld.

In addition, when a CLEC seeks to expand its existing Collocation space, and there is no adjoining space available, the CLEC may provide interconnection facilities

between the non-adjoining CLEC Collocation spaces through CLEC-to-CLEC connections.

4.7 Adjacent Space Collocation

4.7.1 Availability

There will be situations where space is exhausted in a QWEST premises to accommodate physical collocation. Under these circumstances, the CLEC may request space in an adjacent premises such as a Controlled Environmental Vault (CEV), hut, or similar structure located on or under QWEST property. Adjacent Collocation will be on an existing QWEST controlled CEV, hut, or similar structures on or under QWEST owned, leased or otherwise controlled property contiguous to a QWEST premises; however, QWEST shall permit CLEC to construct or otherwise procure such an adjacent structure on property owned, leased, or otherwise controlled by QWEST - subject to OSHA, EPA, Federal, State and local safety and maintenance requirements.

If CEVs (Controlled Environment Vault) and similar structures belonging to Qwest are not located on property contiguous to the Premise, they will not be considered as viable adjacent space candidates for purposes of Adjacent Collocation.

Any off-site leasing arrangement entered into by a CLEC and a party, other than QWEST, to lease space for CLEC equipment placement is not within the scope of collocation.

Non-standard entrance facilities such as copper cable, will be reviewed through the Bona Fide Request (BFR) process and, if approved will require a suitable protection arrangement for the copper cable. Protection that may be required related to such entrance facilities will obligate the CLEC to obtain a physical collocation within the QWEST premises for placing lighting or voltage protection unit on standard connector blocks on a distribution frame. All copper cables used for Interconnection must come through cable vault/entrance facility and have sheaths grounded/bounded (See section 2.7 for further information).

4.7.2 CLEC Responsibilities

Where space is not available in an existing QWEST structure, the CLEC is responsible for constructing the adjacent structure in accordance with QWEST design and space planning for the site. CLEC may propose the design for the

adjacent structure subject to QWEST's approval which approval may not be unreasonably withheld or delayed.

The CLEC shall be responsible for all alarming and monitoring within its structure.

The CLEC is responsible for all engineering and installation activities and costs associated with placing the structure. The CLEC owns the structure. The CLEC must meet all local building, fire and zoning codes; CLEC is responsible for

construction and procuring all building and zoning. The CLEC must obtain all variances and building permits required to build a structure.

QWEST may require the CLEC to complete certain legal arrangements with QWEST prior to the start of construction, including submission of a request for adjacent collocation on the current Collocation Application Form containing, in addition to the normal General Ordering Information,:

- Dimensions of the CLEC-owned or leased structure;
- Weight and material specifications of the structure and architectural diagrams;
- AC powering requirements (voltage phases and currents of structures where the CLEC desires that QWEST provide the AC power);
- Direct Connection of the Adjacent Collocation site will also require completion of the Collocation Application Form (Direct Connection).

QWEST assumes no responsibility for protection or liability for damages due to theft, vandalism, fire, moving vehicles, natural disasters of CLEC-owned structures placed on QWEST property.

During work stoppage activities, CLEC shall be responsible for coordinating with the unions involved and public safety officials to obtain access.

4.7.3 QWEST Requirements

The CLEC and QWEST will negotiate as to the type and location of the structure (subject to legal requirements discussed in Section 4.7.2) on QWEST property. The normal structure is expected to be a CEV, but other types of structures will be considered. QWEST will not unreasonably deny or delay approval of a CLEC proposed design. QWEST will consider modular buildings owned by the CLEC and designed for primary use as telecommunications functions.

Where an existing QWEST structure is utilized for adjacent collocation, the interval for Physical Collocation shall apply.

4.7.4 Power

The CLEC may arrange for regular commercial AC power with the local utility. The CLEC may also install their own standby engine alternator. Alternatively, the CLEC may obtain Essential AC power from QWEST.

The CLEC may obtain power for a non-existing adjacent structure by several means

4.7.4.1 CLEC Provides Power

The CLEC will provide power itself by obtaining an AC power feed from the local power company and install an AC/DC power plant.

4.7.4.1.2 CLEC Provides its own AC and DC Power

This method utilizes an AC power pedestal (separate AC source/meter outside the building), and the power pedestal may be served by a portable engine. The Adjacent Collocation has its own power plant.

This is the way Qwest configures the power for our own CEVs today. The CLEC can elect to supply a portable engine, stored off site, and brought in to power the site in case of an emergency.

4.7.4.1.3 CLEC provides all AC and DC (if needed) and a permanent auto-start, auto-transfer standby engine-alternator

This method utilizes an AC power pedestal (separate AC source/meter outside the building). If required by the CLEC, the adjacent collocation will have its own DC power plant. The CLEC is responsible for the following:

1. Meeting noise restrictions. Noise levels are not to exceed 75 dBA at a distance of 25' from the engine. Lower sound levels may be required by ordinances/codes and is the responsibility of the CLEC to understand and comply with local ordinances and codes
2. obtaining local operating and emission permits for any engines.
3. responding to any neighbor complaints
4. seek local government and Qwest approval for fuel type and storage arrangements.
5. Additional work and cost to install an engine and an automatic transfer switch.
6. for tank monitoring to comply with EPA and local government requirements

4.7.4.2 CLEC Obtains Power from Qwest

4.7.4.2.1 Qwest provides Essential AC power

CLEC will need to provide an entrance into the structure and a main distribution panel/box to which Qwest can terminate their AC feeds. In some cases, essential AC capacity may not be available immediately, necessitating some delay in provisioning of services.

4.7.4.2.2 Qwest provides DC power feeds from Premise and CLEC provides power for AC power loads

In some cases, DC capacity may not be available immediately, necessitating some delay in provisioning of services. One bay (or portion thereof) will be needed for

the CLEC to supply Qwest a BDFB (Battery Distribution Fuse Board) or other fuse/breaker panel for termination of the Qwest DC feeds.

4.7.4.2.3 Qwest provides AC and DC power feeds from Premise

The CLEC will need to provide an entrance into the structure and a main distribution panel/box to which Qwest can terminate their AC feeds. One bay (or portion thereof) will be needed for the CLEC to supply Qwest a BDFB (Battery Distribution Fuse Board) or other fuse/breaker panel for termination of the Qwest DC feeds.

In some cases, power capacity may not be available immediately, necessitating some delay in provisioning of services.

After initial order any power augment charges will be the sole responsibility of the CLEC.

Qwest will run power cable (when requested) from the Qwest Premise power to Adjacent Collocation structures owned by a CLEC that is placed on Qwest property. All costs and intervals will be on an ICB (individual case basis). Voltage drops and the cost of power cables at such distances can be extremely costly to the CLEC.

Power cable running to such structures on Qwest property will require trenching and conduit placement for the cables involved. All costs and intervals will be ICB, based on the cabling requirements, distances, trenching activities.

4.7.5 Entrance Facility into the Wire Center

The entrance facility for this application into the wire center may be fiber or metallic pairs. See Chapter 2 for further information. This arrangement would be used in a shared ICDF arrangement.

The CLEC may alternatively place Direct Connection - Point of Terminations (as described Chapter 3) in their CEV or other structure.

4.7.6 CEV and Hut Requirements

QWEST uses several standards for building CEVs and huts. While QWEST does not require CLEC-owned CEVs and huts to meet these standards in their entirety, the portions of these standards that could impact conditions outside of the CEV or hut

do apply. An example of such a standard is the CEV roof strength. Inadequate roof strength could lead to failure of the parking lot over the CEV.

QWEST currently uses the following Telcordia publications:

GR-26-CORE	Generic Requirements for Controlled Environment Vaults (CEVs)
GR-27-CORE	Generic Requirements for Environmental Control Systems for Electronic Equipment Enclosures
GR-43-CORE	Generic Requirements for Telecommunications Huts

While older CEVs and huts were built prior to QWEST adopting these standards, newer structures are built to the standards.

The CLEC may choose to meet the remainder of these requirements when building their structure.

If CEVs (Controlled Environment Vault) and similar structures belonging to Qwest are not located on property contiguous to the Premise, they will not be considered as viable adjacent space candidates for purposes of Adjacent Collocation.

4.7.7 Adjacent Remote Collocation

Adjacent Remote Collocation - allows CLEC to physically collocate equipment in or on a non-contiguous Qwest property adjacent to a Qwest Remote Premises (i.e. Remote Terminal, FDI or CEV) for the purpose on interconnecting Qwest to purchase sub-loop elements.

Adjacent Remote Collocation in an existing structure shall be considered and ordered as Remote Collocation (See also Tech. Pub #77405).

Any equipment placed in a QWEST owned CEV must meet the same requirements as if it were placed in a wire center. In addition, standards described in GR-26-CORE and GR-27-CORE must be met. See Section 4.7.6 for further information.

4.8 Facility Connected (FC) Collocation

Qwest Facility Connected (FC) Collocation is available for CLECs/DLECs that need to access Qwest's UNEs, Ancillary Services, or Finished Services within a Qwest CO without establishing an actual physical collocation at the associated Qwest CO. FC Collocation utilized the various different types of entrance facilities to allow the CLECs to access the desired Qwest's UNEs, Ancillary Services, or Finished Services within a Qwest CO. See section 2.8 for additional information on FC Collocation

FC Collocation is available with the following configurations:

- 4.8.1 Copper Entrance Facility for termination and cross-connection to appropriate Digital Service Level 0 (DS0) and Digital Service Level 1 (DS1) UNE services (if utilized for DS1 UNEs, you must transmit a Trunk Level 1 (T1) templated signal over the copper facility). DS1 Copper entrance facilities will be wired to a DS1 office repeater, or comparable CO equipment, to remove line voltage before terminating on the Digital System Cross-Connect (DSX) panel. Reference section 2.8.1.2 and 2.8.1.3 for detailed information on DS1 FC Collocation.
- 4.8.2 Fiber Entrance Facility termination and cross-connection to appropriate fiber UNEs
- 4.8.3 Other levels of service such as DS1 or Digital Service Level 3 (DS3) with fiber are available using the Bona Fide Request (BFR) process.

See section 2.8 for additional information on FC Collocation.

4.9 Common Area Splitter Collocation

A CLEC may place POTS splitters in QWEST central offices via Common Area Splitter Collocation. In this scenario, a CLEC will have the option to either purchase the POTS splitter of its choosing or to have QWEST purchase the POTS splitter on the CLEC's behalf. Further details for Common Area Splitter Collocation are set forth more fully in the "Interconnection - Shared Loop" Technical Publication (Tech. Pub. # 77406).

Subject to full reimbursement, the CLEC will lease the POTS splitter to QWEST at no cost. Subject to agreed to or ordered pricing, QWEST will install and maintain the POTS splitter in the central office. QWEST will install the POTS splitter in one of three locations in the central office:

4.10 Remote Collocation

Remote Collocation - allows a CLEC to physically collocate in or adjacent to a Qwest outside plant facility structure that is located remote from a Qwest central office building property. The details for Remote Collocation are set forth more fully in the "Unbundled Sub-Loops and Field Interconnection" Technical Publication (Tech Pub. # 77405)

4.11 Conversion of Virtual Collocation to Cageless Physical Collocation

Existing Virtual Collocation (Section 4.2) arrangements may be converted to Cageless Physical Collocation (Section 4.5) under certain conditions. All equipment located in the bay must belong to the CLEC. This conversion option is not available if any equipment in the bay belongs to another carrier.

A CLEC wishing to add additional equipment to a converted partly filled bay may have to add power capacity and other cables to the bay.

4.12 Summary of Collocation Arrangements

Table 4-1 summarizes the characteristics of the various types of collocation arrangements that have collocated equipment (that is, IDE).

Specifications of Shared Space Caged Physical Collocation describe in Section 4.4.2 are in the "Physical" column.

Table 4-1 Collocation Comparison Summary

Feature (Section)	Virtual (4.2)	Caged Physical (4.3 & 4.4)	ICDF (4.6)	Cageless Physical (4.5)
Size, occupancy	Negotiated	Typical multiples of 100 ft ² . May be shared per Section 4.4	Negotiated	1 bay or multiples of 1 bay. Limited to 1 CLEC
Bay depths	Standard QWEST depths	Determined by CLEC	Standard QWEST depths	Standard QWEST depths
Install & maintain equipment	QWEST	CLEC	QWEST	CLEC
Cage or Enclosure	No	Yes	No	No
Provides Equipment	CLEC, lease to QWEST	CLEC	Qwest	CLEC
Determines equipment bay location	QWEST	CLEC, within QWEST-designated area	Qwest	QWEST
Equipment located	Intermingled with other providers	Located in CLEC's designated area	Intermingled with other providers	Adjacent or Intermingled
CLEC access to Wire Center	To place jumpers on NI, otherwise no	Yes	Yes	Yes
NI required for connections to UNE	Yes	Yes	Yes	Yes
Set equipment options, keep records of options and jumpers	CLEC (QWEST will set equipment options as directed by CLEC)	CLEC	CLEC	CLEC
Place jumpers on "Design-To" cross-connect #	QWEST	QWEST	QWEST	QWEST
Design responsibility to "Design-To" point	CLEC	CLEC	CLEC	CLEC
Termination Capacity	As required *	As required *	As required *	As required *
- 48 volt DC Power, Essential AC power (Optional)	Normal QWEST standard	Optionally provided via cable taken to enclosure at CLEC request		Provided bay at a time via a BDFB or PBD.
Entrance Facility	Optional	Optional	Optional	Optional
Circuit & equipment design work by	CLEC	CLEC	CLEC	CLEC

BDFB = Battery Distribution Fuse Board.

PBD =Power Board Distribution

* In multiples of 100 DS0/Voice pairs, one (1) DS1 systems or 1 DS3 or above system. See also Chapter 3.

Assumes the "Design-To Point" is different than the ICDF.

CONTENTS

Chapter and Section	Page
5. Responsibilities.....	5-1
5.1 Basic Responsibilities.....	5-1
5.2 "Design-To" Point.....	5-1
5.3 Design Responsibilities -- Digital Unbundled Elements.....	5-3
5.4 Design Responsibilities -- Analog Unbundled Elements.....	5-4
5.5 Design Responsibilities -- Optical Unbundled Elements.....	5-4
5.6 Design Responsibilities with Finished Services	5-4
5.7 Design Responsibilities without Collocated Equipment.....	5-4
5.8 Record Keeping and Forecasting Requirements	5-5
5.9 Basic Configurations for Multiple Equipment Locations.....	5-5
5.10 Test Access for Equipment and Tie Cables	5-6

Figures

5-1 Typical Wire Center Arrangement.....	5-2
5-2 Configurations for Multiple Equipment Locations.....	5-6

5. Responsibilities

5.1 Basic Responsibilities

Competitive Local Exchange Carriers (CLECs) interconnecting with QWEST jointly share the responsibilities of providing service to the CLEC's customer. The CLEC has the responsibility to design the service for their customer. The CLEC provides this service using a combination of their own equipment and facilities and Unbundled Network Elements (UNEs) or Finished Services provided by QWEST.

While the CLEC has overall design responsibility, QWEST has the responsibility to design the UNEs and Finished Services ordered by the CLEC from QWEST.

Both carriers are also responsible to provision and maintain the portions of the network for which they have design responsibility. This will include keeping appropriate records.

This chapter describes some of these responsibilities in detail. Other chapters in this publication also describe additional responsibilities. Tariffs, contracts and regulatory orders also define responsibilities.

The responsibilities for QWEST-provided Finished Services are as described in Chapter 16 and in the appropriate tariff, catalog or technical publication.

5.2 "Design-To" Point

Chapter 3 described the Interconnection arrangements and introduced the "Design-To" concept. The arrangements using a separate InterConnection Distribution Frame (ICDF) frame have a "Design-To" cross-connect frame that is separate from the Network Interface (NI). The shared ICDF arrangement may alternatively have only one cross-connect that serves both the "Design-To" and NI function. This alternative will vary depending on the wire center.

Figure 5-1 illustrates a wire center with a separate ICDF as described in Chapter 3.

The cross-connect designated the "Design-To" point is mentioned in other chapters and other QWEST technical publications about UNEs dealing with DS0/Voice, DS1, DS3, and fiber or optical interfaces. Network Channel Interface (NCI) codes may be listed in these chapters to identify signals at those points even though the cross-connects are not NIs. The actual NCI codes for the NI at the ICDF will use the "QB" and "QC" Protocol Codes for DS1, DS3 or fiber/optical and DS0/Voice, respectively, as defined in the appropriate chapters. These codes are generic in the sense that templated signals will not normally appear at the ICDF NI. These same NCI codes are used at the NI for the NO ICDF arrangement.

The "Design-To" point may have little meaning in designing analog voice grade applications since the transmission design must also reflect the requirements of equipment and facilities on the QWEST side of the NI. The CLEC must design the circuits in a normal manner to fit the transmission requirements of the facilities from the IDE, through the ICDF, and on to the eventual customer interface or equipment.

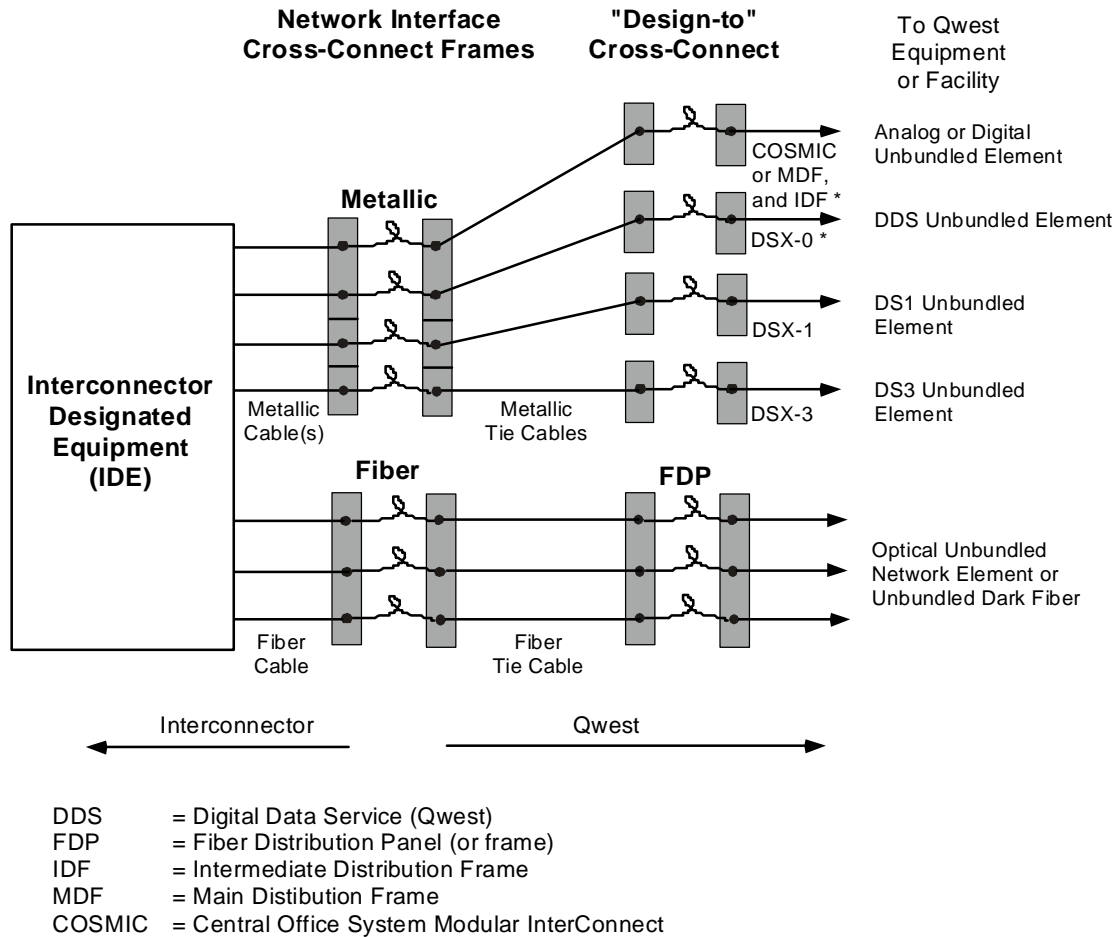

Figure 5-1: Typical Wire Center Arrangement

There is a cross-connect frame located at the analog "Design-To" point. This may be a COSMIC®, Toll or Trunk Main Distribution Frame (TMDF), Intermediate Distribution Frame (IDF) or Main Distribution Frame (MDF) for Unbundled Loop, Unbundled Switch Port or Unbundled Dedicated Interoffice Transport UNEs. Other frames may serve these functions in some wire centers.

However, in the case of DS1 and DS3 channels (and any other channels or services that use DS1 or DS3 interconnections), the design processes will require some modification if the ICDF is not a DSX-1 or DSX-3 cross-connect frame with templated signals.

The DSX-1 or DSX-3 cross-connect panel will still exist. The channels from the IDE must still be designed to have a templated DSX-1 or DSX-3 signal at the DSX as defined by the "DS" Network Channel Protocol codes (Chapters 6, 7 and 8). This means that the signal levels at the ICDF NI typically will not be a templated signal.

QWEST may substitute appropriate Digital Cross-Connect Systems (DCSs) for manual DSX-1 or DSX-3 cross-connect panels in some wire centers. Chapter 15 discusses some of the changes in design under these circumstances.

The situation when connecting to DS0 digital data is similar. A DSX-0 frame will still have a templated DSX-0 signal. In most wire centers, however, an IDF will be used to serve the DSX-0 function and a separate DSX-0 cross-connect frame will not be used. The design from the IDE must be such that a DSX-0 templated signal is presented to the DSX-0/IDF frame. See Chapter 10 for further information.

This publication makes a distinction between the DS0 digital data DSX-0 cross-connect and the analog MDF, TMDF or IDF cross-connect for technical transmission design differences even though the two frame functions may physically be on the same cross-connect frame and occupy the same area on the ICDF. Other documents may not make this distinction.

5.3 Design Responsibilities -- Digital Unbundled Elements

Connections to digital UNEs have the characteristic of having a DSX-0, DSX-1 or DSX-3 cross-connect at the "Design-To" point. The design responsibilities are simplified by having a templated signal at the DSX frame.

The portion of the QWEST-provided UNE from the DSX "Design-To" point through the QWEST network will be designed and installed by QWEST.

Responsibilities for the portion of the UNE from the "Design-To" DSX to the ICDF (and beyond on the CLEC's side) are the responsibility of the CLEC.

The signal at the ICDF in wire centers where the ICDF is also the "Design-to" point will be a templated signal. The tie cables will not exist. The CLEC's design must be adjusted to reflect this difference.

The Interconnector will have final End-to-End design responsibility for their service.

5.4 Design Responsibilities -- Analog Unbundled Elements

The CLEC must use accepted design criteria used in the industry to design their service.

Analog UNEs will frequently have some equipment on the QWEST side of the NI. This often takes the form of a channel unit in a channel bank or a switch.

One notable exception to this is many (but not all) of the Unbundled Loop UNEs. These may consist only of a copper facility. However, the loops may also be derived facilities on carrier systems.

Technical publications describing the analog UNEs will contain further information.

5.5 Design Responsibilities -- Optical Unbundled Elements

Interconnection of optical signals will require some joint engineering. See Chapter 12 for further information.

5.6 Design Responsibilities with Finished Services

See Chapter 16 for this information.

5.7 Design Responsibilities without Collocated Equipment

Interconnectors wishing to recombine various UNEs and/or Finished Services in a wire center may do so by the placement of appropriate jumpers on the NI frame. CLEC services involving Finished Services and UNEs will have to provide a facility from the CLEC-POT (where the Finished Service terminates) to the ICDF (where the UNE terminates). However, the CLEC still has overall design responsibility for the service that they provide to their customers. The CLEC must order the appropriate UNE and specify any options required for these elements.

The type of Collocation used to combine UNEs together without any Collocated equipment (i.e., IDE) is called ICDF Collocation.

A CLEC wishing to connect to a Finished Service must have Physical or Virtual Collocation in some form to provide a location at which to connect the Finished Service to another Finished Service or a UNE. Active transmission equipment may not be required. ICDF Collocation does not apply in this context.

5.8 Record Keeping and Forecasting Requirements

The CLEC is requested to develop capacity forecasts for each wire center in which they wish to connect to UNEs. This forecast will allow QWEST to plan the frame space and tie cable network appropriately.

The requirements for the different Interconnection arrangements will not be the same. Chapter 3 should be consulted for further information.

Included in this forecast will be frame capacity, tie cable requirements between the NI frame and the UNEs to which they wish to connect and tie cable capacity required to terminate their IDE. Tie cable forecasts will be required for Unbundled Loop elements, Unbundled Switch Port elements, Unbundled Dedicated Interoffice Transport elements and other UNEs.

This itemization is required since the tie cables may terminate in different areas of the wire center. Some variation in forecast requirements may be expected for different types of switch and frame configurations.

All terminations on the NI frame will have a frame address. QWEST will assign and maintain frame address records for the frame. QWEST will provide the UNE frame address to the CLEC for each UNE the CLEC orders. QWEST will maintain assignment records of these UNEs and connections to the NI frame.

The CLEC will maintain assignment records for the terminations of their own equipment. The CLEC will also maintain the assignment records for connections on the NI frame. The CLEC will be required to make the jumper wire connection between frame addresses to complete their circuit.

This discussion is probably not complete. Other record keeping and forecasting requirements may exist and are identified in this and other publications as well as other sources.

5.9 Basic Configurations for Multiple Equipment Locations

Collocation in a QWEST wire center requires the CLEC to do some basic planning on how they will interconnect with others. The manner in which they interconnect becomes more complex for arrangements where their IDE is located in different areas in the wire center. This is most pronounced with Cageless Physical and Virtual Collocation.

The basic issue is how the CLEC plans to connect their Entrance Facility from the Collocation Point of Interconnection (CPOI) to their IDE and connect their IDE to the ICDF.

Figure 5-2 illustrates two potential configurations that the CLEC could employ. For convenience, they are called *Direct* and *Hubbed*. The CLEC may choose either, both or some other configuration that will meet their needs.

The solid lines represent cables that connect each IDE location directly to the CPOI and the ICDF.

The dashed lines represent the hubbed configuration. IDE location #2 serves as a hub. The CPOI, ICDF and all the other IDE locations are cabled to the hub at IDE #2. Connections are made as needed.

Cables at each level (DS0 or voice, DS1, DS3, and fiber or optical) would be placed as needed.

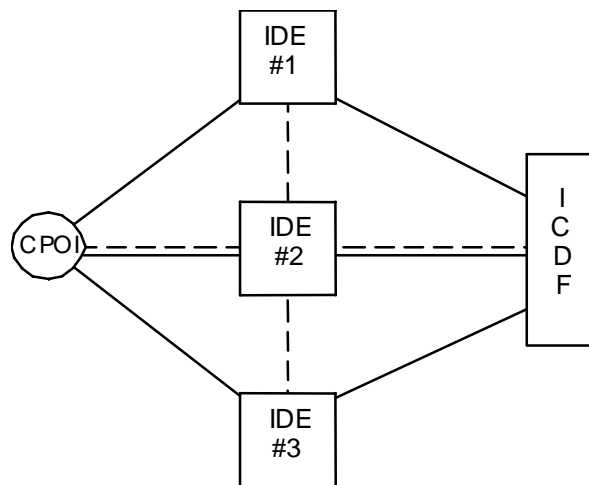

- Legend:**
- Direct Configuration
 - - - Hubbed
 - CPOI = Collocation Point of
 - ICDF = InterConnection Distribution Frame
 - IDE = Interconnector Designated

Figure 5-2: Configurations for Multiple Equipment Locations

5.10 Test Access for Equipment and Tie Cables

The CLEC may test at the ICDF either from the front or back of the block or panel as appropriate. Test access is also available at their IDE. The CLEC may also test at the “Design-To” Point cross-connect frame if different from the ICDF.

QWEST may test at the ICDF and at other points in the QWEST network.

The party placing the jumper on the ICDF has the responsibility of testing the jumper. If both parties are involved in a coordinated testing effort, both parties may participate in the testing of the jumper.

The CLEC may also test at other locations as defined by contracts or other sources. These additional access points are beyond the scope of this technical publication.

CONTENTS

Chapter and Section	Page
6. Network Channel and Network Channel Interface Codes -- General	6-1
6.1 Network Channel (NC) Codes	6-1
6.2 Network Channel Interface (NCI) Codes	6-2
6.2.1 NCI Format	6-2
6.2.2 Example	6-4
6.3 Summary	6-4
6.4 NC and NCI Codes for Jumpers	6-4

Figures

6-1 Format Structure for NC Codes	6-1
6-2 Format Structure for NCI Codes	6-3

Tables

6-1 NCI Impedance Values	6-3
6-2 NCI Transmission Levels	6-5
6-3 NC and NCI Codes for Ordering Jumpers	6-6
6-4 NC Code Definitions	6-6
6-5 NCI Code Definitions	6-7

6. Network Channel and Network Channel Interface Codes -- General

Network Channel (NC) and Network Channel Interface (NCI) codes convey technical parameters of the service. NC and NCI codes are a part of the COMMON LANGUAGE® code set. This chapter explains the codes in a general manner to aid in the selection of compatible code combinations as presented in the next chapter. NC and NCI codes are provided by the customer to the QWEST Service Representative at the time a request for service is initiated. The specific meaning of codes is described in the references listed in the chapters describing the specific services.

A complete description of the basic NC and NCI code format can be found in ANSI T1.223-1997, *Information Interchange – Structure and Representation of Network Channel (NC) and Network Channel Interface (NCI) Codes for the North American Telecommunications System*.

6.1 Network Channel (NC) Codes

Network Channel Codes are used to represent the channel and channel options of the transport service.

A NC code is a four-character code with two data elements:

- Channel Code
- Optional Feature Code

The format is illustrated in Figure 6-1.

Network Channel Code				
Data Element	Channel Code		Optional Feature Code	
Character Position	1	2	3	4
Character Key	X	X	X or -	X or -

- X = Alphanumeric
- = Hyphen

Figure 6-1: Format Structure for NC Codes

The **Channel Code** (character position 1 and 2) is a two-character alpha or alphanumeric code that describes the channel service in an abbreviated form. The channel code will frequently, but not always, be specified as the service code of the special service circuits or the transmission grade of the message trunk circuit. The NC channel code field is always filled.

The **Optional Feature Code** (character position 3 and 4) is a two-character alpha or alphanumeric or hyphen code that represents the option codes available for each channel code. Varying combinations of this code will allow the customer to enhance the technical performance of the requested channel, or to further identify the type of service. It is also used to specify options such as conditioning, effective 4-wire, multiplexing, etc. The NC Optional Feature Code field is always filled.

The NC codes shown for the EICT's illustrate how QWEST perceives the EICT and Interconnector's channel from a technical standpoint but should not be used to order the EICT.

6.2 Network Channel Interface (NCI) Codes

Technical specifications for an interface are encoded into NCI codes. An NCI code tells the QWEST Engineer and the circuit design system, of the specific technical customer requirements at a Network Interface.

This section gives a brief description of the NCI code format. Specific technical information about the NCI codes may be found in the appropriate technical publication. Some additional information may be found later in this document in the chapters describing the specific services.

6.2.1 NCI Format

An NCI code is a maximum twelve-character code that consists of five (5) data elements:

- Total Conductors
- Protocol
- Impedance
- Protocol Options
- Transmission Level Point(s) (TLP)

The first three fields are required. The last two are generally optional but may be required in certain situations. The format is illustrated in Figure 6-2.

Total Conductors (character positions 1 and 2) is a two-character numeric code that represents the total number of physical conductors (e.g., wires or fibers) required at the interface.

Protocol (character position 3 and 4) is a two-character alpha code that defines requirements for the interface regarding signaling/transmission.

Impedance (character position 5) is a one-character alpha or numeric code representing the nominal reference impedance, presented toward the network, that will terminate the channel for the purpose of evaluating transmission performance. Values are listed in Table 6-1

Network Channel Interface Code

Total Conductors		Protocol		I m p e d a n c e	D e l i m e t e r	Protocol Options			D e l i m i t e r	TLP Level	
										T r a n s m i t	R e c e i v e
1	2	3	4	5	6	7	8	9	10	11	12
N	N	A	A	X	•	X	X	X	•	X or -	X or -

- A = Alpha
- N = Numeric
- X = Alphanumeric
- = Delimiter (normally a period)
- = Hyphen

Figure 6-2: Format Structure for NCI Codes

Table 6-1: NCI Impedance Values

Impedance in Ohms (Character Position 5)			
Data Value	Code	Data Value	Code
110	0	124	7
150	1	Variable	8
600	2	100	9
900	3 *	Fiber	F
1200	4	Radio	Z
135	5	50 Coaxial	C
75	6		

* Except for interface code 04DD3, the impedance character 3, when used with a 4-wire voice-frequency path at the POT, denotes a historical customer (Interexchange Carrier) provided transmission termination rather than a 900 ohm impedance. Such terminations were provided by customers in accordance with FCC Docket No. 20099 settlement Agreement and by Automatic Transmission Test and Control Circuit used in the previous provisioning process.

Protocol Options (character positions 7, 8, and 9) is a one to three character alpha, numeric, or alphanumeric code that describes additional features (e.g., bit rate or bandwidth) on the Protocol to be used. It is an optional field that is always left justified.

Transmission Level Point(s) (character positions 8 through 12) is assigned one or two-character alpha code corresponding to a value for Transmission Level Point(s) (TLPs) from either the Exchange Carrier/service provider or customer end. Values are listed in Table 6-3.

The convention for TLP Levels is as follows:

- Transmitting TLP Level signifies the TLP transmit signal level at the QWEST interface when transmitting to the customer.
- Receiving TLP Level signifies the TLP transmit signal level at the QWEST interface when receiving from the customer.

6.2.2 Example

A compatible NCI code for the NC code DS1 HC-- (Table 8-2) is 04DS9.15. The "04" indicates that there are four (4) conductors (metallic wires in this case). The "DS" describes the interface as Digital Hierarchy Interface (See the reference publication listed in Chapter 8 for further information). The impedance value of "9" indicates 100 ohms (Table 6-2). The option codes "15" indicate Superframe and Alternate Mark Inversion (SF and AMI) as described in Table 8-2 and the reference publication.

6.3 Summary

Typical applications of NC and NCI code usage are discussed in the chapters about the specific service. The NCI and NC codes will allow customer specified technical information to pass through the ordering process and enable generation of the requested circuit design.

6.4 NC and NCI Codes for Jumpers

Under certain circumstances, an Interconnector may have to order jumpers from QWEST. This may be due to contracts, regulatory orders or other circumstances.

These jumpers are connections on the same cross-connect frame. These jumpers may be used to connect collocated equipment to Unbundled Network Elements (UNEs), collocated equipment to collocated equipment, UNEs to UNEs or other situations described elsewhere in this publication. Subsequent chapters should be consulted for further information about specific situations.

Unless otherwise stated, the NC and NCI codes listed in Table 6-3 should be used. Tables 6-4 and 6-5 define these NC and NCI codes respectively.

Table 6-2: NCI Transmission Levels

Transmission Level Point Code (Character Positions 11 and 12)	
Data Value	Code
-16.0	A
-15.0	B
-14.0	C
-13.0	D
-12.0	E
-11.0	F
-10.0	G
-9.0	H
Fractional TLPs	I
-8.0	J
-7.0	K
-6.0	L
-5.0	M
-4.0	N
None This Direction (One-way Service)	O
-3.0	P
-2.0	Q
-1.0	R
0.0	S
+1.0	T
+2.0	U
+3.0	V
+4.0	W
+5.0	X
+6.0	Y
+7.0	Z
QWEST Specified	- *
Recommended	(Blank) *

* Not valid for Unbundled Elements. TLPs must be specified for analog interfaces.

Table 6-3: NC and NCI Codes for Ordering Jumpers

Application	Description	NC Code	NCI Code
DS0/Voice - HDSL *	HDSL	LX--	02QB9.00H
DS0/Voice - Other	64 kbit/s or voice	LX--	02QB2.00
DS0/Voice	Transmission only, no Signaling	LX--	02QC2.OOF
DS1	SF & AMI	HC--	04QB9.11 04QB9.11
	SF & AMI	HCX-	
	SF & B8ZS	HCXA	
	Non-ANSI ESF & AMI	HCXB	
	Non-ANSI ESF & B8ZS	HCXC	
	ANSI ESF & AMI	HCXD	
	ANSI ESF & B8ZS	HCXE	
	Free Framing & B8ZS	HCXF	
DS3	44.736 Mbit/s	HFX-	04QB6.33
		HF--	04QB6.33
Fiber or Optical	Fiber Jumper for optical/Ethernet	LX--	01QBF.LLX
		LX--	02QBF.LLX

* High-bit-rate Digital Subscriber Line.

AMI = Alternate Mark Inversion
ANSI = American National Standards Institute
B8ZS = Bipolar with 8 Zero Substitution
ESF = Extended Super Frame
SF = Superframe Format

Table 6-4: NC Code Definitions

NC Code			Description
LX	-	-	Dedicated Facility (Without Equipment)
HC			High Capacity Channel (DS1)
	X		Central Office Cross-Connect, DS1-to-DS1 Intact
		*	* Fourth position defines line code and frame format as shown in Table 6-3.
HF			High Capacity Channel (DS3)
	X		Central Office Cross-Connect
		-	DS3-to-DS3

Table 6-5: NCI Code Definitions

NCI Code					Description
01					One Conductor
02					Two Conductors
04					Four Conductors
	QB				Central Office Manual Cross-Connect Termination With No Subrating Capability
		2			600 Ohms
		6			75 Ohms
		9			100 Ohms
		F			Fiber
			00		Main Distribution Frame Cross-Connect *
				H	HDSL
			11		DS1-to-DS1 (This code may or may not meet DS1 signal levels as specified by GR-342-CORE.)
			33		DS3-to-DS3 (This code may or may not meet DS1 signal levels as specified by GR-342-CORE.)
			LL		Fiber Cross-Connect on Fiber Distribution Bay (or equivalent)
				X	Dark Fiber

* Also applies to other DS0 or Voice cross-connect frames including Intermediate Distribution Frame (IDF) and Common System Main Interconnecting Frame (COSMIC®).

These NC and NCI codes could be used for Central Office Connecting Channels if not defined elsewhere.

CONTENTS

Chapter and Section	Page
7. DS3 Interconnection.....	7-1
7.1 Connections to Unbundled Network Elements or Finished Services	7-1
7.1.1 Finished Services.....	7-1
7.1.2 Unbundled Network Elements (UNEs).....	7-1
7.2 DS3 “Design-To” Point.....	7-2
7.3 DS3 Terminations and Tie Cables.....	7-2
7.4 Network Channel & Network Channel Interface Codes	7-2
Tables	
7-1 Applicable DS3 NCI Codes for UNEs.....	7-3
7-2 Applicable DS3 “Design-To” Codes.....	7-3
7-3 Commonly Used NC Codes for DS3 Services or UNEs	7-4

7. DS3 Interconnection

7.1 Connections to Unbundled Network Elements or Finished Services

A Competitive Local Exchange Carrier (CLEC) may connect their collocated Interconnector Designated Equipment (IDE) to various DS3-level Finished Services or Unbundled Network Elements (UNE). A CLEC may also connect various Finished Services and/or UNEs together if technically compatible. These connections are made at a DS3 Network Interface (NI) identified by a Network Channel Interface (NCI) code.

The services or UNEs must be compatible (i.e., with compatible Network Channel (NC) and NCI codes) to ensure proper operation of the resulting CLEC network. The NC and NCI codes are discussed later in this chapter.

7.1.1 Finished Services

The QWEST DS3 Service is a private line transport service providing a high performance, point-to-point channel operating at the rate of 44.736 Mbit/s. Variations of frame format and other options (e.g., Central Office Multiplexing) are available.

Further information about the DS3 Service may be found in QWEST Technical Publication 77324, *QWEST DS3 Service*. This publication provides technical specifications for the DS3 Service channels and interfaces.

A DS3 Service may be ordered direct to an End-User customer premises network interface or to a Carrier Point of Termination (POT). See Chapter 16 for further information about interconnection with Finished Services.

The NI at the CLEC end of a Finished Service is at a POT. The NI may be selected from those listed in PUB 77324. The NCI codes for Interexchange Carriers would apply unless otherwise noted.

Other Finished Services may also use DS3 NIs that may be interconnected by a CLEC.

Finished Services may be ordered using Section 21 of Tariff FCC #1. See Section 16.5 of this publication for further information.

7.1.2 Unbundled Network Elements (UNEs)

The DS3 Unbundled Dedicated Interoffice Transport element is one UNE that may be interconnected at the DS3 level. This UNE has many features in common with the DS3 Service. See Appendix B for further information.

The NI for a UNE is normally an InterConnection Distribution Frame (ICDF) or Direct Connection - Point of Termination (DC-POT) as discussed in Chapter 3.

7.2 DS3 “Design-To” Point

The “Design-To” point for a UNE is normally a DSX-3 cross-connect panel with DSX-3 templated signal conditions.

The span from the IDE, through the ICDF or DC-POT, to the DSX-3 must be designed to present a templated DSX-3 signal to the DSX-3 panel. The “Design-To” could be represented by a NCI code such as 04DS6.44 if it was a NI.

Similar requirements must be met when connecting Finished Services and UNEs together.

There may be some wire centers where a DS3/1 Digital Cross-Connect System is substituted for a manual DSX-3.

The DS3 “Design-To” Point may be a DSX-3 serving as the ICDF in some wire centers.

7.3 DS3 Terminations and Tie Cables

DS3 ICDF terminations on the DS3 portion of the ICDF will be provided in multiples of one four-wire termination when a DS3 UNE is ordered. Two coaxial tie cables to the appropriate “Design-To” DSX-3 will be provided by QWEST. Each pair of cables will provide a capacity of one DS3 two-way channel.

Slightly different descriptions apply for DC-POT arrangement as described in Chapter 3.

The appropriate tariff, catalog or contract should be consulted for further information concerning ordering instructions for tie cables and ICDF terminations.

7.4 Network Channel & Network Channel Interface Codes

This section provides the NC and NCI codes and combinations to use when establishing a connection between collocated IDE, DS3 Finished Services or UNEs.

There are a number of NC and NCI codes that may be encountered with collocation at the DS3 level. Table 7-1 lists the applicable NCI code representing the NI between the Interconnector and QWEST at the ICDF or DC-POT.

Table 7-1: Applicable DS3 NCI Codes for UNEs

NCI Code	Description
04QB6.33	Central Office Manual Cross-connect Termination With No Subrating Capability, DS3 to DS3 *

* This Network Interface may or may not meet DS3 signal levels as specified by PUB 77324.

If the “Design-To” point were a network interface, it would be described by the NCI codes in Table 7-2. These NCI codes are **not** used in the UNE ordering process (even if the ICDF is a DSX-3), but may be informative when designing the network.

These NCI codes may be valid NCI codes for Finished Services at the POT. See PUB 77324 for further information.

Table 7-2: Applicable DS3 “Design-To” Codes

Design-To Code	Description
04DS6.44	Digital Hierarchy Interface, 44.736 Mbit/s, (DS3) M2/3 Format
04DS6.44I	Digital Hierarchy Interface, 44.736 Mbit/s, DS3 C-bit parity - 28 DS1 Channels

Table 7-3 lists commonly used NC codes representing the channels of the QWEST DS3 UNE to which an Interconnector connects. The third character values of either “-” or “C” are valid with the fourth character values of either “-”, “1”, “4”, “7” or “M”. PUB 77324 contains a more complete listing of valid DS3 NC codes for Finished Services.

The fourth character “-” denotes a two-point channel. The remaining fourth character options denote some form of DS3-to-DS1 multiplexing.

Table 7-3: Commonly Used NC Codes for DS3 Services or UNEs

Channel Code	Option Code	Char 3	Option Code	Char 4
HF †	None	-	Unchannelized	- *
	C-bit Parity	C	CO Mux Assignment of 1 DS1 CCC (B8ZS) at a time per card	1 **
			CO Mux Assignment of 4 DS1 CCC (B8ZS) at a time per card	4 **
			CO Mux Assignment of 7 DS1 CCC (B8ZS) at a time per card	7 **
			CO Multiplexing	M **

* May be M2/3 format.

** M2/3 format.

† HF denotes 44.736 Mbit/s DS3 High Capacity service. See PUB 77324 for a complete listing.

Technical publications describing the specific Finished Service or UNE should be consulted for the applicable NC and NCI codes.

All the listed NC codes are compatible with the NCI code 04QB6.33 at the Network Interface. However, the CLEC must insure that M2/3 format and C-bit Parity options match when connecting two channels together at the ICDF or DC-POT to enable the proper operation of their network.

CONTENTS

Chapter and Section	Page
8. DS1 Interconnection.....	8-1
8.1 Connections to Unbundled Network Elements or Finished Services	8-1
8.1.1 Finished Services.....	8-1
8.1.2 Unbundled Network Elements (UNEs).....	8-1
8.2 DS1 “Design-To” Point.....	8-2
8.3 DS1 Terminations and Tie Cables.....	8-2
8.4 Network Channel & Network Channel Interface Codes	8-2

Tables

8-1 Applicable DS1 NCI Codes for UNEs.....	8-2
8-2 Applicable DS1 “Design-To” Codes.....	8-3
8-3 Commonly Used NC Codes For DS1 Services or UNEs	8-4

8. DS1 Interconnection

8.1 Connections to Unbundled Network Elements or Finished Services

A Competitive Local Exchange Carrier (CLEC) may connect their collocated Interconnector Designated Equipment (IDE) to various DS1-level Finished Services or Unbundled Network Elements (UNEs). A CLEC may also connect various Finished Services and/or UNEs together if technically compatible. These connections are made at a DS1 Network Interface (NI) identified by a Network Channel Interface (NCI) code.

The services or UNEs must be compatible (i.e., with compatible Network Channel (NC) and NCI codes) to ensure proper operation of the resulting CLEC network. The NC and NCI codes are discussed later in this chapter.

8.1.1 Finished Services

The QWEST DS1 Service is a private line transport service providing a high performance, point-to-point channel operating at the rate of 1.544 Mbit/s. Variations of line coding, frame format, and other options (e.g., Central Office Multiplexing) are available.

Further information about the DS1 Service may be found in QWEST Technical Publications 77200, *QWEST DS1 Service and Synchronization Service*, and 77375, *1.544 Mbit/s Channel Interfaces*. These publications provide technical specifications for the DS1 Service and interfaces respectively.

A DS1 Service may be ordered direct to an End-User customer premise NI or to a Carrier Point of Termination (POT). See Chapter 16 for further information about interconnection with Finished Services.

The NI at the CLEC end of a Finished Service is at a POT. The NI may be selected from those listed in PUBS 77375 or 77200. The NCI codes for Interexchange Carrier POTs would apply unless otherwise noted.

Other Finished Services may use DS1 network interfaces and may be interconnected by a CLEC.

Finished Services may be ordered using Section 21 of Tariff FCC #1. See Section 16.5 of this publication for further information.

8.1.2 Unbundled Network Elements (UNEs)

The DS1 Unbundled Dedicated Interoffice Transport element is one UNE that may be interconnected at the DS1 level. This UNE has many features in common with the DS1 Service. See Appendix B for further information.

The NI for a UNE is normally an InterConnection Distribution Frame (ICDF) or Direct Connection - Point of Termination (DC-POT) cross-connect frame as discussed in Chapter 3.

8.2 DS1 “Design-To” Point

The “Design-To” point is normally a DSX-1 cross-connect panel with DSX-1 templated signal conditions.

There may be some wire centers where a DS1/0 Digital Cross-Connect System is substituted for a manual DSX-1.

The span from the IDE, through the ICDF or DC-POT, to the DSX-1 must be designed to present a templated DSX-1 signal to the DSX-1 panel. The “Design-To” could be represented by a NCI code such as 04DS9.15 if it was a NI.

Similar requirements must be met when connecting Finished Services and UNEs together.

8.3 DS1 Terminations and Tie Cables

DS1 ICDF terminations on the DS1 portion of the ICDF will be provided when the UNEs are ordered. Slightly different information about the DC-POT arrangement may be found in Chapter 3.

The appropriate tariff, catalog or contract should be consulted for further information concerning ordering instructions for tie cables and ICDF terminations.

8.4 Network Channel & Network Channel Interface Codes

This section provides the NC and NCI codes and combinations to use when establishing a connection between the collocated IDE, DS1 Finished Services or UNEs.

There are a number of NC and NCI codes that may be encountered with collocation at the DS1 level. Table 8-1 lists the applicable NCI code representing the NI between the Interconnector and QWEST at the ICDF or DC-POT.

Table 8-1: Applicable DS1 NCI Codes for UNEs

NCI Code	Description
04QB9.11	Central Office Manual Cross-connect Termination With No Subrating Capability, DS1 to DS1 *

* This Network Interface may or may not meet DS1 signal levels as specified by PUB 77375.

If the “Design-To” point were a network interface, it would be described by the NCI codes in Table 8-2. These NCI codes are **not** used in the UNE ordering process (even if the ICDF is a DSX-1), but may be informative when designing the network.

These NCI codes may be valid NCI codes for Finished Services at the POT. See PUB 77375 or 77200 for further information.

Table 8-2: Applicable DS1 “Design-To” Codes

Design-To Code	Description
04DS9.15	Digital Hierarchy Interface, 1.544 Mbit/s (DS1), Superframe (SF) Format and Alternate Mark Inversion (AMI) Line Code
04DS9.15B	Digital Hierarchy Interface, 1.544 Mbit/s (DS1), SF and Bipolar Eight Zero Substitution (B8ZS) Line Code
04DS9.15J	Digital Hierarchy Interface, 1.544 Mbit/s (DS1), Free Framing and B8ZS
04DS9.15K	Digital Hierarchy Interface, 1.544 Mbit/s (DS1), Non-American National Standards Institute Extended Superframe (Non-ANSI ESF) and AMI
04DS9.15S	Digital Hierarchy Interface, 1.544 Mbit/s (DS1), Non-ANSI ESF and B8ZS
04DS9.1K	Digital Hierarchy Interface, 1.544 Mbit/s (DS1), ANSI ESF and AMI
04DS9.1S	Digital Hierarchy Interface, 1.544 Mbit/s (DS1), ANSI ESF and B8ZS

Table 8-3 lists commonly used NC codes representing the channels of the QWEST DS1 UNE to which an Interconnector connects. The third character “J” is valid only with the fourth character “-”. The remaining third character values are valid with both the fourth character “-” and “G”. PUB 77200 contains a more complete listing of valid NC codes for Finished Services.

The fourth character “-” denotes a two-point channel. The fourth character “G” denotes a channel with DS1-to-Voice or Digital Data multiplexing.

Table 8-3: Commonly Used NC Codes For DS1 Services or UNEs

Channel Code	Option Code	Char 3	Option Code	Char 4
HC *	SF and AMI	-	None (i.e., a unchannelized channel)	-
	SF and B8ZS	Z	Central Office Multiplexing, Voice and Digital Data	G
	ANSI ESF and AMI	D		
	ANSI ESF and B8ZS	E		
	Non-ANSI ESF and AMI	F		
	Non-ANSI ESF and B8ZS	G		
	Free Framing and B8ZS	J	None (i.e., an unchannelized channel)	-

* HC denotes 1.544 Mbit/s DS1 High Capacity service. See PUB 77200 for a complete listing.

Technical publications describing the specific Finished Service or UNE should be consulted for the applicable NC and NCI codes.

All the listed NC codes are compatible with the NCI code 04QB9.11 at the Network Interface. However, the CLEC must insure that line codes and frame formats match when connecting two channels together at the ICDF or DC-POT to enable the proper operation of their network.

CONTENTS

Chapter and Section	Page
9. Analog Interconnection.....	9-1
9.1 Connections to Unbundled Network Elements or Finished Services	9-1
9.1.1 Finished Services.....	9-1
9.1.2 Unbundled Network Elements (UNE)	9-2
9.2 Analog Voice “Design-To” Point.....	9-2
9.3 DS0/Voice Terminations and Tie Cables	9-2
9.4 Network Channel & Network Channel Interface Codes	9-2
9.4.1 Network Interface NCI Codes.....	9-2
9.4.2 Commonly Used Network Channel Codes.....	9-3
9.5 Non-Access Services.....	9-5
9.6 Circuit Design.....	9-5

Tables

9-1	Applicable Analog Voice Level NCI Codes for UNEs	9-3
9-2	Commonly Used NC Codes for Analog UNEs	9-4
9-3	Commonly Used NCI Codes for Analog UNEs	9-4
9-4	NCI Protocol and Protocol Option Codes	9-5

9. Analog Interconnection

9.1 Connections to Unbundled Network Elements or Finished Services

A Competitive Local Exchange Carrier (CLEC) may connect their collocated Interconnector Designated Equipment (IDE) to various DS0 or voice-level Finished Services or Unbundled Network Elements (UNEs). A CLEC may also connect various services and/or UNEs together if technically compatible. These connections are made at a voice-level Network Interface (NI) identified by a Network Channel Interface (NCI) code.

The services or UNEs must be compatible (i.e., with compatible Network Channel (NC) and NCI codes) to ensure proper operation of the resulting network. The NC and NCI codes are discussed later in this chapter.

9.1.1 Finished Services

There are a number of Finished Services available under the Analog Private Line Transport Service (PLTS) umbrella. See Chapter 16 for further information.

Analog Voice Grade Special Access Services are suitable for the access segments of line-type, trunk-type, and private line data services. Usable frequencies are nominally 300 to 3000 Hz. Some voice grade categories include services such as switched specials, voice/tone relaying, etc. Further information about these services may be found in PUB 77310, *Private Line Voice Grade Analog Channels For Access Service*.

Low-Speed, Direct Current and Telegraph Grade Services are non-switched, two-point or multipoint circuits capable of data rates up to 150 baud. Typical applications include control, status, alarm, metering, telegraph and teletypewriter. Further information on these services may be found in PUB 77307, *Low Speed Data, Telegraph and direct Current Services*. Refer to the appropriate tariff, catalog or contract for availability of these channels.

These Pubs include a caveat that the service may be transported on metallic cable pairs or on digital loop carrier, at the discretion of QWEST. The appropriate tariff, catalog or contract may override this caveat. The portion of the service provided by the Interconnector is usually carrier based and non-metallic. These services are available only if the Interconnector can provide a suitable channel unit as discussed later in this chapter.

A DS0 or voice Finished Service may be ordered direct to an End-User customer premise NI or to a Carrier Point of Termination (POT). See Chapter 16 for further information about interconnection with Finished Services.

The NI at the CLEC end of a Finished Service is at a POT. Where the Pubs discuss an Interexchange Carrier POT, for Network Channel (NC) and Network Channel Interface (NCI) coding purposes, it should be understood that the interface to Interconnector equipment is accepted as the equivalent.

Information about some of these Finished Services is not included in this publication since no equivalent UNE is available. See the publication that describes the service for further information.

9.1.2 Unbundled Network Elements (UNE)

The Unbundled Loop element is one UNE that may be interconnected at the DS0 or voice level. See Appendix B for further information.

The NI for a UNE is normally an InterConnection Distribution Frame (ICDF) or Direct Connection - Point of Termination (DC-POT) cross-connect frame as discussed in Chapter 3.

9.2 Analog Voice “Design-To” Point

The “Design-To” point is normally a Main Distribution Frame (MDF), Intermediate Distribution Frame (IDF) of some type, or a COSMIC® cross-connect frame.

The “Design-To” concept does not significantly impact analog services since the UNEs must be designed in the same manner as any analog service.

9.3 DS0/Voice Terminations and Tie Cables

DS0/voice ICDF or DC-POT terminations on the DS0/voice portion of the ICDF or DC-POT are provided when the UNEs are ordered. Tie cables in multiples of 100 pairs to the appropriate “Design-To” cross-connect frame will be provided by QWEST. The capacity of 100 pairs is dependent on the type of service transported.

The appropriate tariff, catalog or contract should be consulted for further information concerning ordering instructions for tie cables and ICDF or DC-POT terminations.

9.4 Network Channel & Network Channel Interface Codes

9.4.1 Network Interface NCI Codes

This section provides the NC and NCI code combinations to use when establishing a connection between the IDE and a QWEST analog Private Line Transport Service or UNE.

The NIs for analog UNEs use the “QC” family of NCI codes. The “QC” NCI Protocol Code denotes *Manual Cross-Connect DS0/Voice*.

Table 9-1 lists the “QC” protocol code and the associated protocol option codes for positions 3, 4, 7, 8, and 9 of the NCI code set. The remaining positions are described in Chapter 6 along with NCI code information found in the publications listed in Section 9.1.1.

Table 9-1: Applicable Analog Voice Level NCI Codes for UNEs

NCI Code Position				Definition
3 & 4	7	8	9	
QC				Central Office Manual cross-connect DS0/voice termination
	O	O	B	Ground Start Loop Signaling, open end
	O	O	C	Ground Start Loop Signaling, closed end
	O	O	D	Loop Start Loop Signaling, open end
	O	O	E	Loop Start Loop Signaling, closed end
	O	O	F	Transmission only, no signaling
	R	V	O	Reverse Battery Originating: Loop closure provided by the Access Customer (AC) to the Access Provider (AP); Battery provided by AP to AC. *
	R	V	T	Reverse Battery Terminating: Loop closure provided by the AP to the AC; Battery Provided by AC to AP. *

* The Access Provider (AP) is QWEST. The Access Customer (AC) is CLEC (or their customer).

The protocol option codes indicate the basic type of interface. The codes suggest the generic type of channel unit used in the IDE channel bank. Section 9.6 discusses the circuit design process in detail.

A special note about “open” and “closed” ends. If the Interconnector has the switch (open end), the interface will be the closed end (e.g., 02QC2.OOE or 02QC2.OOC). Similarly, if the Interconnector has the closed end, the interface will be the open end (e.g., 02QC2.OOD or 02QC2.OOB).

9.4.2 Commonly Used Network Channel Codes

Table 9-2 lists some commonly used NC codes that may be encountered with UNEs. The table identifies the reference publication for a similar Finished Service. Information about UNEs may be found in Appendix B. The services or elements are grouped by heavy lines. The codes apply only within a group. The list of UNEs is a subset of these codes.

Table 9-3 lists the corresponding NCI codes. The “Nominal” NCI code is the NCI code that would be used when interfacing with an Access Customer (e.g., an Interexchange Carrier) in a normal PLTS access arrangement. The Interconnector NCI code is the corresponding “QC” NCI code used when connecting an Interconnector with QWEST.

The voice grade services (VG1 through VG10 and VG 12) use a complex set of NC/NCI combinations beyond the scope of this publication. PUB 77310 should be consulted for further information.

Table 9-2: Commonly Used NC Codes for Analog UNEs

Unbundled Network Element		Reference Publication	NC Codes
VG1	Voice Grade 1	PUB 77310	LB--
VG2	Voice Grade 2	PUB 77310	LC--
VG3	Voice Grade 3	PUB 77310	LD--
VG4	Voice Grade 4	PUB 77310	LE--
VG5	Voice Grade 5	PUB 77310	LF--
VG6	Voice Grade 6	PUB 77310	LG--
VG7	Voice Grade 7	PUB 77310	LH--
VG9	Voice Grade 9	PUB 77310	LK--
VG10	Voice Grade 10	PUB 77310	LN--
VG12	Voice Grade 12	PUB 77310	LR--

Table 9-3: Commonly Used NCI Codes for Analog UNEs

Signaling Type	Interconnector	Nominal *
Ground Start	02QC2.OOB	02GO2
	02QC2.OOC	02GS2
Loop Start	02QC2.OOD	02LO2
	02QC2.OOE	02LS2
No Signaling	02QC2.OOF	02NO2
	04QC2.OOF	04NO2
Reverse Battery	02QC2.RVO	02RV2.O
	02QC2.RVT	02RV2.T

* See Table 9-4 and PUB 77310 for description and applicability.

These “Nominal” NCI codes are usually the codes available at the POT for a Finished Service. See the appropriate reference document for further information.

Some Finished Services may require that the Interconnector provide IDE between the channel unit and the Network Interface indicated by the “QC” NCI code.

Table 9-4: NCI Protocol and Protocol Option Codes

Protocol		Definition *
Code 3 4	Option 7 8 9	
GO		Ground-start signaling -- open end (switch) function presented by Access Customer at interface to QWEST Access Service.
GS		Ground-start signaling -- closed end (station) function presented by Access Customer or End-user at interface to QWEST Access Service.
LO		Loop-start loop signaling -- open end (switch) function presented by customer at interface to QWEST Access Service.
LS		Loop-start signaling -- closed end (station) function presented by the customer at the interface to QWEST access service.
NO		Connects customer to an Access Service suitable for voice transmission with no signaling provided by QWEST
RV		Reverse battery (Trunk signaling) at interface
	O	Loop closure provided by Access Customer to QWEST; Battery provided by QWEST to Access Customer
	T	Loop closure provided by QWEST to End-user; Battery provided by End-user to QWEST

* The standard definitions defined in the reference documents should be modified to fit the Collocation application. For example, the term “Interconnector” or “AEC” should be substituted for “IC-POT” or “IC” in the standard definitions.

9.5 Non-Access Services

PUB 77320, *QWEST Private Line Services*, and PUB 77311, *Analog Channels for Non-Access Service*, describe QWEST’s Non-Access Voice Grade PLTSs. With the introduction of an Interconnector, any such service ordered from QWEST would be ordered as the equivalent Voice Grade Access Service described in PUB 77310. These services (Voice Grades 1 through 10 and 12) are listed in Table 9-2.

9.6 Circuit Design

Once the order for the UNE or Finished Service has been placed, if requested, QWEST will provide design information about the connected transport facility providing the PLTS from the Interconnector’s NI out to the End-User or Interexchange Carrier customer interface. The Interconnector will then use this information to design and set options for their IDE. The Interconnector will have overall responsibility for the End-to-End performance standards. Certain UNEs require the Interconnector to provide additional design functions.

CONTENTS

Chapter and Section	Page
10. Interconnection at DS0 Digital Level	10-1
10.1 Connections to Unbundled Network Elements or Finished Services	10-1
10.1.1 Finished Services	10-1
10.1.2 Unbundled Network Elements (UNEs).....	10-1
10.2 DS0 "Design-To" Point.....	10-2
10.3 DS0 Terminations and Tie Cables.....	10-2
10.4 Composite Clock Requirements	10-2
10.5 Network Channel & Network Channel Interface Codes	10-3
10.6.1 Network Interface Codes	10-3
10.6.2 Network Channel Codes.....	10-4

Tables

10-1 NCI Code Options -- DDS and ISDN.....	10-4
10-2 Digital Data Channel Applications	10-5

10. Interconnection at DS0 Digital Level

10.1 Connections to Unbundled Network Elements or Finished Services

A Competitive Local Exchange Carrier (CLEC) may connect their collocated Interconnector Designated Equipment (IDE) to various DS0-level Finished Services or Unbundled Network Elements (UNEs). A CLEC may also connect various Finished Services and/or UNEs together if technically compatible. These connections are made at a DS0 Network Interface identified by a Network Channel Interface (NCI) code.

The Finished Services or UNEs must be compatible (i.e., with compatible Network Channel (NC) and NCI codes) to ensure proper operation of the resulting network. The NC and NCI codes are discussed later in this chapter.

10.1.1 Finished Services

The QWEST Digital Data Service (DDS) provides a channel with the capability of transmitting digital data. The available data rates are 2.4, 4.8, 9.6, 19.2, 56.0 and 64.0 kbit/s. The service provides full-duplex 4-Wire transmission of synchronous serial data between customer locations. Further information about the service may be found in PUB 77204, *QWEST Digital Data Service, Product Description, Applications, and Interface Combinations*, and in PUB 77312, *QWEST Digital Data Service Technical Descriptions*. The latter document describes the interfaces.

These Pubs include a caveat that the service may be transported on metallic cable pairs or on digital loop carrier, at the discretion of QWEST. The tariff, catalog or contract may override this caveat. The portion of the service provided by an Interconnector will be carrier- based and thus non-metallic.

The NI at the CLEC end of a Finished Service is at a POT. The NI may be selected from those listed in PUBS 77312 or 77204. The NCI codes for Interexchange Carriers would apply unless otherwise noted. See Chapter 16 for further information about interconnection with Finished Services.

Other Finished Services may use DS0 network interfaces and may be interconnected by a CLEC.

10.1.2 Unbundled Network Elements (UNEs)

The Unbundled Non-loaded Loop element is one UNE that may be interconnected at the DS0 level. This UNE has features in common with the DDS Service. See Appendix B for further information.

The Network Interface is normally an InterConnection Distribution Frame (ICDF) or Direct Connection - Point of Termination cross-connect frame as discussed in Chapter 3.

10.2 DS0 “Design-To” Point

There are two types of “Design-To” points for this application.

One type of “Design-To” point is encountered when feeding a metallic loop. This “Design-To” point is the Main Distribution Frame (MDF) or COSMIC® frame and the design must include the entire metallic loop.

The other type is a DSX-0 templated signal intended to connect to other electronic equipment. The “Design-To” point for this interface is sometimes a DSX-0 cross-connect frame but is usually a termination on the MDF, Intermediate Distribution Frame (IDF) or COSMIC® frame with DSX-0 templated signal conditions. The distance limit to the DSX-0 is 1500 feet. This is not normally a problem in most wire centers. The CLEC will have to make other arrangements if the 1500 foot limit is exceeded.

The span from the IDE, through the ICDF bay or frame, to the DSX-0 must be designed to present a templated DSX-0 signal to the DSX-0 cross-connect. The “Design-To” could be represented by a Network Channel Interface (NCI) code such as 04DO5.E (56 kbit/s DS0-A, see Table 10-1) even though it is not a Network Interface.

Similar requirements must be met when connecting Finished Services and UNEs together.

10.3 DS0 Terminations and Tie Cables

DS0 ICDF terminations on the DS0/voice portion of the ICDF are provided when the UNE is ordered. Tie cables in multiples of 100 pairs to the appropriate “Design-To” DSX-0 will be provided by QWEST. The capacity of these pairs is dependent on the service or UNEs being carried. Normally, DDS uses two pairs.

These terminations and tie cables may be shared with analog voice channels except when a separate DSX-0 cross-connect panel is in the wire center. In this case, the tie pairs to the DSX-0 must be segregated from those going to the MDF/COSMIC® frame.

The appropriate tariff, catalog or contract should be consulted for further information concerning ordering instructions for tie cables and ICDF terminations.

10.4 Composite Clock Requirements

Digital services, such as DDS, place an additional requirement to be able to provide a working service. The Interconnector must obtain Composite Clock for their channel bank (or the equivalent) from QWEST. The signal is used by the Office Interface Unit (OIU) in the channel bank to provide phase and frequency synchronization to the DDS or other DS0 digital channels. This requirement ensures that phase alignment will be maintained between the Interconnector’s channel bank and any QWEST network elements.

Other equipment may require Composite Clock, DS1 Clock, or combinations of the two clock signals. See Chapter 13 for further information of the clock signals.

10.5 Network Channel & Network Channel Interface Codes

This section provides the NC and NCI code combinations to use when establishing a connection with the related DS0-level digital Finished Services or UNEs. Information in this section is generic. The appropriate technical publication describing the Finished Service or UNE should be consulted for further information.

10.6.1 Network Interface Codes

Two NCI codes are involved with DDS applications: the “QB” and the “QC” Protocol Codes. The “DO” protocol code applies at a “Design-To” point with the “QB” protocol code.

The 04QB5.00 NCI code is used for the DSX-0 templated signal application. “QB” in this context means *Manual Cross-Connect Termination With No Subrating Capability, MDF Cross-Connect*. The matching “Design-To” code is the “DO” protocol code.

The “DO” code is described as *Digital Interface at the Digital Signal Level Zero (DS0)*. This code describes the signal at the “Design-To” point, a DSX-0 cross-connect or the functional equivalent. The “DO” codes are not used for orders for UNEs, but are used to identify the technical parameters to which the IDE to DSX-0 segment must be designed. The “DO” code is described in PUB 77312.

The interface requires that the Interconnector obtain Composite Clock (Section 13.3) from QWEST to synchronize their multiplexer or channel bank to the same clock source as the channel bank or DLC Central Office Terminal (COT) (when appropriate) provided by QWEST.

The Interconnector must provide a channel unit generically known as a DS0-DP channel unit to meet this interface. QWEST will provide a matching DS0-DP in their channel bank, DLC COT, or other equipment on their side of the interface.

Basic Rate Integrated Services Digital Network (ISDN) or Private Line ISDN services may also use the “QC” NCI codes for Interconnection. The appropriate “QC” codes are listed in Table 10-1. The appropriate publication for the service or UNE should be consulted for further information.

The “QC” code is used to denote *Manual Cross-Connect DS0/Voice Termination*. This code represents the Network Interface at the ICDF bay or frame. The “QC” code is used when the channel is being connected is a metallic loop. The Interconnector would provide a channel unit generically known as an Office Channel Unit-Data Port (OCU-DP) to feed the metallic loop.

Table 10-1 lists the “QB”, “QC” and “DO” option codes for positions 3, 4, 7, 8, and 9 of the NCI code. The remaining positions would be as described in Chapter 6 along with NCI code information found in the publications listed in Section 10.1.

Table 10-1: NCI Code Options -- DDS and ISDN

NCI Code Position				Definition
3 & 4	7	8	9	
DO				Digital Interface at the Digital Signal Level Zero (DS0)
	A			DS0-A at 2.4 kbit/s
	B			DS0-A at 4.8 kbit/s
	C			DS0-A at 9.6 kbit/s
	D			DS0-A at 19.2 kbit/s
	E			DS0-A at 56.0 kbit/s
	F			DS0-A at 64.0 kbit/s
QB	0	0		Central Office Manual Cross-Connect Termination With No Subrating Capability, MDF Cross-Connect
QC				Central Office Manual Cross-Connect DS0/Voice
				<u>DDS</u>
	O	O	J	2.4 kbit/s Digital Service
	O	O	K	4.8 kbit/s Digital Service
	O	O	L	9.6 kbit/s Digital Service
	O	O	M	19.2 kbit/s Digital Service
	O	O	P	56.0 kbit/s Digital Service
	O	O	Q	64.0 kbit/s Digital Service
				<u>ISDN *</u>
	O	O	S	LT function presented to Service Provider
	O	O	V	NT function presented to Service Provider

* Basic Rate ISDN (Digital Subscriber Line - DSL)

10.6.2 Network Channel Codes

The NC codes used with DDS service connections are listed in Table 10-2. Further information about the QWEST Digital Data Service may be found in PUB 77204. The NC codes used with other services (if applicable) may be found in the publications describing the appropriate service.

Some of the codes in Table 10-2 also apply to UNEs. Appendix B should be consulted for further information.

Table 10-2: Digital Data Channel Applications

NC Code	Low Level NCI Code	Description/Application *
XA--	04QB5.00	2.4 kbit/s, not DS0A Level signal
XA--	04QC5.OOJ	2.4 kbit/s, DS0A Level signal
XAB-	04QB5.00	2.4 kbit/s, with secondary channel, not DS0A Level signal
XAB-	04QC5.OOJ	2.4 kbit/s, with secondary channel, DS0A Level signal
XB--	04QB5.00	4.8 kbit/s, not DS0A Level signal
XB--	04QC5.OOK	4.8 kbit/s, DS0A Level signal
XBB-	04QB5.00	4.8 kbit/s, with secondary channel, not DS0A Level signal
XBB-	04QC5.OOK	4.8 kbit/s, with secondary channel, DS0A Level signal
XG--	04QB5.00	9.6 kbit/s, not DS0A Level signal
XG--	04QC5.OOL	9.6 kbit/s, DS0A Level signal
XGB-	04QB5.00	9.6 kbit/s, with secondary channel, not DS0A Level signal
XGB-	04QC5.OOL	9.6 kbit/s, with secondary channel, DS0A Level signal
XC--	04QB5.00	19.2 kbit/s, not DS0A Level signal
XC--	04QC5.OOM	19.2 kbit/s, DS0A Level signal
XCB-	04QB5.00	19.2 kbit/s, with secondary channel, not DS0A Level signal
XCB-	04QC5.OOM	19.2 kbit/s, with secondary channel, DS0A Level signal
XH--	04QB5.00	56.0 kbit/s, not DS0A Level signal
XH--	04QC5.OOP	56.0 kbit/s, DS0A Level signal
XHB-	04QB5.00	56.0 kbit/s, with secondary channel, not DS0A Level signal
XHB-	04QC5.OOP	56.0 kbit/s, with secondary channel, DS0A Level signal
XD--	04QB5.00	64.0 kbit/s, not DS0A Level signal
XD--	04QC5.OOQ	64.0 kbit/s, DS0A Level signal

* QC is defined as *Central Office manual cross-connect DS0/voice termination*. The Description column provides additional options
 QB is defined as *Central Office manual cross-connect termination with no subrating capability*. The option "00" denotes an MDF or DSX-0-like cross-connect.

CONTENTS

Chapter and Section	Page
11. Frame Relay Service.....	11-1
11.1 General.....	11-1
11.2 Network Interfaces for Frame Relay Service	11-1
11.3 Compatible Network Channel & Network Channel Interface Codes....	11-1
11.3.1 Access Port -- 56/64 kbit/s.....	11-2
11.3.2 Access Port -- Fractional 1.544 Mbit/s	11-2
11.4.3 Access Port -- 1.544 Mbit/s.....	11-2
11.4.4 Network Channel Interface Codes	11-3

Tables

11-1 Codes for a Frame Relay Service Application at 56/64 kbit/s.....	11-2
11-2 Codes for a Frame Relay Service Application for Fractional DS1	11-2
11-3 Codes for a Frame Relay Service Application at 1.544 Mbit/s.....	11-3
11-4 Applicable NCI Codes at POT	11-3

11. Frame Relay Service

11.1 General

QWEST Frame Relay Service employs digital packet or "fast packet" technology with access speeds of 56 kbit/s, 64 kbit/s, and 1.544 Mbit/s to provide a high-speed connection-oriented data transfer service. "Fast Packet" technology may be classified as having two types of packets: cells and frames. Frame Relay is a frame-oriented packet technology that supports variable frame sizes to cost effectively support bursty applications (e.g., Local Area Network [LAN] interconnection and file transfers), which contain both variable bandwidth requirements and low delay requirements. Cell-type packets do not apply with Frame Relay Service.

QWEST Frame Relay Service utilizes Permanent Virtual Circuits to establish logical connections between customer locations to provide higher access speeds and less delay than traditional packet-switch technologies. Instead of multiple physical dedicated lines, multiple logical connections may be established on a single Frame Relay Service Access Port to provide simultaneous logical connections between customer Network Interfaces.

Frame Relay Service is also available with 1.544 Mbit/s (DS1) access ports for Fractional DS1 access channels.

Further information about the Frame Relay Service may be found in PUB 77372, *QWEST Frame Relay Service*.

Frame Relay Service is a Finished Service. No similar Unbundled Network Element exists at this time. See Chapter 16 for further information.

11.2 Network Interfaces for Frame Relay Service

A Competitive Local Exchange Carrier (CLEC) may interconnect with the Frame Relay Service at the CLEC-Point of Termination (POT) using two types of Network Interfaces (NIs). They are the 1.544 Mbit/s (DS1) and 44.736 Mbit/s (DS3) NIs. See PUB 77372 for a more complete listing.

An interoffice channel will be required if the Interconnector and the Frame Relay Port are not located in the same wire center. This channel could be either a Finished Service or an unbundled element. The CLEC will have to provide the connections between the interoffice channel and Frame Relay Service.

11.3 Compatible Network Channel & Network Channel Interface Codes

This section provides the Network Channel (NC) and Network Channel Interface (NCI) codes to use when establishing a connection with Frame Relay Service.

11.3.1 Access Port -- 56/64 kbit/s

Access ports to a Frame Relay Service are available at the 56 and 64 kbit/s rate. Appropriate NC codes are listed in Table 11-1.

Table 11-1: Codes for a Frame Relay Service Application at 56/64 kbit/s

Frame Relay Service NC Code	Description
XD-R	64 kbit/s Digital Access Channel, Digital Packet
XH-R	56 kbit/s Digital Access Channel, Digital Packet

11.3.2 Access Port -- Fractional 1.544 Mbit/s

Access ports to a Frame Relay Service are also available at Fractional DS1 rates. The ports use full DS1 (1.544 Mbit/s) channel interfaces as described in PUB 77372. The NC codes are listed in Table 11-2.

Table 11-2: Codes for a Frame Relay Service Application for Fractional DS1

Frame Relay Service NC Code	Description
HXFA	Fractional Access, Fast Packet, 1 Channel (64 kbit/s)
HXFB	Fractional Access, Fast Packet, 2 Channels (128 kbit/s)
HXFD	Fractional Access, Fast Packet, 4 Channels (256 kbit/s)
HXFF	Fractional Access, Fast Packet, 6 Channels (384 kbit/s)
HXFH	Fractional Access, Fast Packet, 8 Channels (512 kbit/s)
HXFL	Fractional Access, Fast Packet, 12 Channels (768 kbit/s)

11.4.3 Access Port -- 1.544 Mbit/s

Access Ports to connect to a Frame Relay Service are available at the DS1 (1.544 Mbit/s) rate. The NC codes are listed in Table 11-3.

Table 11-3: Codes for a Frame Relay Service Application at 1.544 Mbit/s

Frame Relay Service NC Code	Description *
HC-O	DS1 Channel, SF & AMI, Digital Packet NNI
HC-R	DS1 Channel, SF & AMI, Digital Packet UNI
HCEO	DS1 Channel, ANSI ESF & B8ZS, Digital Packet NNI
HCER	DS1 Channel, ANSI ESF & B8ZS, Digital Packet UNI

- * NNI = Network-to-Network Interface
- UNI = User-to-Network Interface
- SF = Superframe Format
- AMI = Alternate Mark Inversion
- ANSI = American National Standards Institute
- ESF = Extended Superframe Format
- B8ZS = Bipolar with 8 Zero Substitution

11.4.4 Network Channel Interface Codes

Table 11-4 lists the applicable NCI codes for use at the POT. The CLEC may have to purchase suitable multiplexing if the NC and NCI codes are not at the same level (i.e., DS1 or DS3). See PUB 77372 and other referenced PUBs for further information.

Table 11-4: Applicable NCI Codes at POT

Level	NCI Code	Description (Reference Publication) *
DS1	04DS9.15, 04DJ9.15	AMI and SF (PUB 77375)
	04DS9.15B, 04DJ9.15B	B8ZS and SF (PUB 77375) **
	04DS9.15K, 04DJ9.15K	AMI and Non-ANSI ESF (PUB 77375)
	04DS9.15S, 04DJ9.15S	B8ZS and Non-ANSI ESF (PUB 77375)
	04DS9.1K, 04DJ9.1K	AMI and ANSI ESF (PUB 77375)
	04DS9.1S, 04DJ9.1S	B8ZS and ANSI ESF (PUB 77375)
DS3	04DS6.44A	M2/3 Format (PUB 77324)

- * DS is defined as a Digital Hierarchy Interface.
DJ is defined as a Carrier-to-Carrier DS1 Interface Specification That is the Result of Joint Engineering.

** B8ZS /SF is not recommended due to the potential replication of in-band alarm codes.

The list of NCI codes and their described interfaces may be modified if Section 21 of FCC #1 (or similar circumstances under other jurisdictions) is used to order Frame Relay Service. See Section 16.5 in this publication for further information

CONTENTS

Chapter and Section	Page
12. Interconnection at Optical Carrier Levels	12-1
12.1 Connections to Unbundled Network Elements or Finished Services	12-1
12.1.1 Finished Services	12-1
12.1.2 Unbundled Network Elements and Unbundled Dark Fiber	12-1
12.2 OC-n Network Interface and “Design-To” Point	12-1
12.2.1 Fiber Cross-Connect Arrangements	12-2
12.2.2 Jumpers and Connectors -- Fiber Distribution Panel	12-2
12.2.3 Jumpers and Connectors -- Fiber ICDF	12-3
12.3 Optical Tie Cables	12-3
12.4 Network Channel & Network Channel Interface Codes	12-3
12.5 Synchronization	12-5

Figures

12-1 Fiber ICDF Arrangement	12-4
-----------------------------------	------

Tables

12-1 Jumper Cable Physical Connector Specifications	12-2
12-2 Applicable OC-n Level NCI Codes	12-5
12-3 Common OC-n Network Channel Codes	12-5

12. Interconnection at Optical Carrier Levels

12.1 Connections to Unbundled Network Elements or Finished Services

A Competitive Local Exchange Carrier (CLEC) may connect their collocated Interconnector Designated Equipment (IDE) to various Optical Carrier level-n (OC-n) Finished Services or Unbundled Network Elements (UNEs). A CLEC may also connect various Finished Services and/or UNEs together. These connections are made at an OC-n Network Interface identified by a Network Channel Interface (NCI) code.

The Finished Services or UNEs must be compatible to ensure proper operation of the resulting network. This means, at a minimum, that the two services or UNEs being connected have compatible Network Channel (NC) and NCI codes. The NC and NCI codes are discussed later in this chapter.

12.1.1 Finished Services

Two Finished Services that use optical connections and may be encountered are Synchronous Service Transport (SST) and Self-Healing Network Service (SHNS). SST is described in PUB 77346, *Synchronous Service Transport*. SHNS is described in PUB 77332, *QWEST Self-Healing Network Service (DS1, DS3, STS-1, OC-3 and OC-12)*.

These Finished Services will be delivered to the CLEC at a Point of Termination (POT) Network Interface (NI) which is located near the IDE location. See Chapter 16 for further information about interconnection with Finished Services.

12.1.2 Unbundled Network Elements and Unbundled Dark Fiber

The NI for fiber or optical UNEs will be a Fiber InterConnection Distribution Frame (ICDF) frame or Direct Connection - Point of Termination (DC-POT). These frames and arrangements were briefly discussed in Chapter 3. Fiber NIs are used with OC-3 and OC-12 Unbundled Dedicated Interoffice Transport (UDIT) and Extended UDIT UNEs. These UNEs are described in PUB 77389, Issue C or later.

Fiber NIs will also be encountered with the Unbundled Dark Fiber offering. This offering is described in QWEST Technical Publication 77383, *Unbundled Dark Fiber*.

12.2 OC-n Network Interface and "Design-To" Point

There is no separate "Design-to" DSX-type panel as encountered with DS1 and DS3 connections. There is a FDP located in the wire center in both the ICDF and DC-POT arrangements that may be in the optical path, but the FDP can not be considered a "Design-To" point. The entire span from LASER to detector must be designed including any cables, splices, connectors, jumpers and attenuators. The FDP is only a part of the design criteria and not the point to design to.

The design process at the optical level will normally require some joint engineering between CLEC and QWEST engineers.

12.2.1 Fiber Cross-Connect Arrangements

The size and type of Fiber ICDF, Fiber DC-POT and FDP will vary depending on the specific wire center. The FDP usage may vary depending on the location and application. Some wire centers may have more than one FDP.

A Fiber Splicing Facility is also found in wire centers within fifty sheath feet of the Outside Plant sheath penetrations. This limitation is to conform to current National Exchange Carrier Association limits intended to decrease fire fuel load in the wire centers. This facility may be a stand-alone bay(s) or enclosure or may be a shelf in the FDP.

Cable from the Fiber Splicing Facility to the FDP and all other intra-building cable must conform to National Electric Code® articles 770-50 and 770-51.

Fiber cables from the IDE, the Fiber Entrance Facility, fiber UNEs or Unbundled Dark Fiber are all terminated on the Fiber ICDF connectors by QWEST.

12.2.2 Jumpers and Connectors -- Fiber Distribution Panel

Single mode fiber jumpers will be provided and installed by QWEST. The type of connectors will be identified by QWEST to match the type used in the FDP.

QWEST's current standard connector type is the "SC" type of Physical Connector (PC), i.e., SC-PC. Some FDPs may use Biconic connectors. Other types of connectors may be used in rare applications. Table 12-1 lists the specifications of these connectors.

Connector Type	Biconic Single Mode	ST® High Performance PC	FC High Performance PC	D4 Super PC	SC UPC
Attenuation 1310 & 1550nm (dB)	Mean 0.35,	Mean 0.25,	Mean 0.25,	Mean 0.25,	Mean .20
Return Loss (dB)	30 typical	≥ 55	≥ 55	≥ 40	≥ 55
Connection durability (dB)	< 0.2 change	< 0.1 change	< 0.2 change	na	< 0.1 change
Number of matings	500	500	500	na	200
Operational temperature	-40° to 85° C	-40° to 85° C	-40° to 85° C	na	-40° to 85° C

Table 12-1: Jumper Cable Physical Connector Specifications

Older installations may use jumpers of other specifications.

Biconic and some older connectors may not support higher rate SONET signals, typically OC-48 and above. The SC-PC type used in newer installations should be able to support higher rates. However, this determination is to be made by the Interconnector when ordering the cable from the IDE to the FDP. Upgrades may be made as outlined in the appropriate tariff, catalog or contract.

Similar issues may be encountered with the Fiber Entrance Facility and Dark Fiber terminations. Terminations of an OC-n UDIT or a SST Service will be of the appropriate type.

12.2.3 Jumpers and Connectors -- Fiber ICDF

The Fiber ICDF will use separate panels to terminate fiber cables to IDE and tie cables for fiber or optical UNEs. Figure 12-1 illustrates a typical arrangement in the wire center. Both UNEs and Unbundled Dark Fiber connections are shown.

Single mode fiber jumpers will be provided by the CLEC. The Fiber ICDFs will use SC-PC type of connectors except as noted in Section 12.2.2.

The description for the other Interconnection arrangements is similar. The ICDF in Figure 12-1 would become a DC-POT in the dedicated arrangement.

12.3 Optical Tie Cables

Optical tie cables will be provided by QWEST between the FDP and Fiber ICDF or DC-POTs as discussed in Chapter 3. However, normally the FDP and Fiber ICDF in Figure 12-1 will be the same frame and tie cables will not be required.

Optical tie cables may be required in some wire centers if there are multiple FDPs. ICDF/DC-POT terminations are available in multiples of two. These terminations and the tie cables will be provided in the same manner as the metallic terminations and tie cables. See Chapter 3 for further information.

The CLEC will have to provide the fiber cables between the IDE and Fiber ICDF or DC-POT if they wish to connect to optical UNEs. The CLEC will also have to provide fiber cables from the POT if they order any optically-based Finished Services.

12.4 Network Channel & Network Channel Interface Codes

A number of NC and NCI codes may be encountered when connecting IDE, UNEs and/or Finished Services. These may be classified in two groups: (1) those that require QWEST to become involved in joint design, and (2) those that do not.

Connections to UNEs and Finished Services (such as SST) require that QWEST participate in the design process to a greater extent than other applications. Other connections do not involve QWEST optical equipment and require minimal QWEST participation in the design process.

Qwest Wire Center

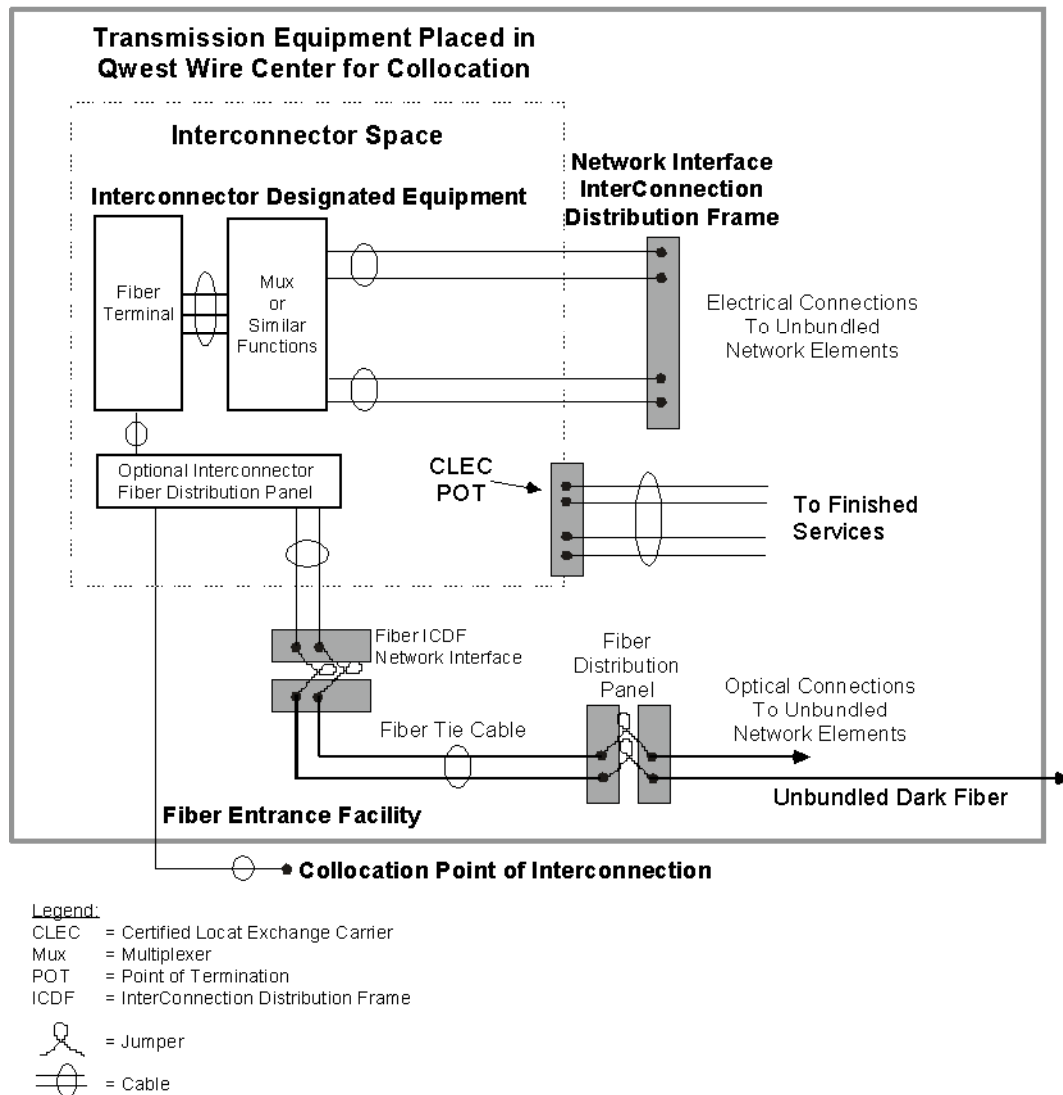

Figure 12-1: Fiber ICDF Arrangement

OC-n level UNEs, SHNS and SST connections to IDE using an optical interconnection require some joint engineering effort to select the proper electrical and optical components to pass optical signals across the NI. This technical information may include wavelengths, loss budget values, OC-n levels, and other required information. The existing NC and NCI code set will define some, but not all, of these technical parameters.

Table 12-2 lists some applicable NCI codes for the Fiber ICDF or DC-POTs that may be used to connect OC-n level UNEs. See the appropriate technical publication for the UNE.

The appropriate technical publication should be consulted for the NCI codes used with Finished Services at the POT.

Table 12-2: Applicable OC-n Level NCI Codes

NCI Code	Description
01QBF.LL 02QBF.LL 04QBF.LL	Central Office Manual Cross-Connect Termination With No Subrating Capability, Fiber Cross-Connect or Fiber Distribution Bay
01QBF.LLX 02QBF.LLX	Central Office Manual Cross-Connect Termination With No Subrating Capability, Fiber Cross-Connect or Fiber Distribution Bay, Dark Fiber

Table 12-3 lists some commonly used NC codes that may be encountered for connections to UNEs or Finished Services. The codes listed are a sample of available channel types. The technical publication for the specific Finished Service or UNE should be consulted for the valid codes for that application.

Table 12-3: Common OC-n Network Channel Codes

NC Code	Description
OB--	OC-3 SONET Point-to-Point (No Central Office Multiplexing)
OD--	OC-12 SONET Point-to-Point (No Central Office Multiplexing)
OF--	OC-48 SONET Point-to-Point (No Central Office Multiplexing)
OB-C	OC-3 SONET Point-to-Point with one Central Office Multiplexer
OD-C	OC-12 SONET Point-to-Point with one Central Office Multiplexer
OF-C	OC-48 SONET Point-to-Point with one Central Office Multiplexer
LX--	Dedicated Facility (No Equipment)

12.5 Synchronization

Since most optical connections involve digital signals, it is likely that synchronization will be required. The CLEC needs to evaluate this need and order Central Office Synchronization (Chapter 13) if required.

CONTENTS

Chapter and Section	Page
13. Central Office Synchronization.....	13-1
13.1 General.....	13-1
13.1.1 Need for Synchronization.....	13-1
13.1.2 Stratum Levels.....	13-1
13.1.3 Primary Reference Source.....	13-3
13.1.4 QWEST Synchronization Network.....	13-3
13.1.5 Customer Requirements	13-3
13.2 Composite Clock Signal	13-5
13.3 DS1 Clock Signal	13-6
13.4 Virtual Collocation Applications	13-6
13.5 Physical Collocation Applications.....	13-7
13.5.1 Digital Connections to Metallic Loops for DS0 Digital Service..	13-7
13.5.2 Digital Connections to Other Facilities for DS0 Digital Service..	13-7
13.5.3 Voice Connections to Metallic Loops for Analog Service	13-7
13.5.4 Voice Connections to Other Facilities for Analog Service	13-8

Figures

13-1 Typical QWEST BITS Arrangement.....	13-4
13-2 DS0 and Composite Clock Signal Timing	13-5
13-3 Composite Clock Waveform	13-6

Tables

13-1 Stratum Level Specifications	13-2
13-2 Expected Slip Performance in Holdover	13-2

13. Central Office Synchronization

13.1 General

13.1.1 Need for Synchronization

Two levels of synchronization are important for digital transmission: bit synchronization and byte synchronization. Bit synchronization refers to the transmitter and the receiver operating at the same rate. Byte synchronization refers to the transmitter and receiver achieving proper alignment by identifying the beginning and end of a frame or byte. Digital signals are synchronized by a concept (Building Integrated Timing Supply or BITS) described in GR-436-CORE, *Digital Network Synchronization Plan*, and in GR-378-CORE, *Timing Signal Generator (TSG) Requirements and Objectives*. A BITS distributes all DS1 and DS0 timing required by other clocks within that building or wire center.

Another good reference source on synchronization is ANSI T1.101-1994, *Synchronization Interface Standard*. This document is consistent with GR-436-CORE, Issue 1.

DS0 synchronization is provided via a composite clock signal. The existing network terminals (e.g., channel banks) with DS0 inputs do not have buffer storage to maintain byte synchronization variations as they are at the DS1 inputs. Thus, these variations are accommodated by requiring that signals at all DS0 level interconnections must be synchronized by a single composite clock source.

Various equipment requires Composite Clock, DS1 Clock or combinations of the two clock signals to provide synchronization.

13.1.2 Stratum Levels

Synchronization Clocks are classified by Stratum Levels. The stratum levels are based on three parameters:

- **Free-run Accuracy:** The maximum fractional frequency offset that a clock may have when it has never had a reference or has been in holdover for an extended period greater than several days or weeks.
- **Holdover stability:** The amount of frequency offset that a clock experiences after it has lost its synchronization reference.
- **Pull-in/Hold-in:** The ability of the clock to achieve or maintain synchronization with a reference that may be off-frequency. A clock is required to have a pull-in/hold-in range at least as wide as its free-run accuracy. This ensures that a clock of a given stratum level can achieve and maintain synchronization with a clock in the same or higher stratum level.

Further information can be found in GR-436-CORE and in GR-1244-CORE, *Clocks for the Synchronized Network: Common Generic Criteria*. Table 13-1 lists the specifications for the various stratum levels.

Table 13-1: Stratum Level Specifications

Stratum Level	Free-Run Accuracy	Holdover Stability	Pull-in/Hold-in
1	$\pm 1.0 \times 10^{-11}$	na	na
2	$\pm 1.6 \times 10^{-8}$	$\pm 1. \times 10^{-10}$ per day	$\pm 1.6 \times 10^{-8}$
3E	$\pm 4.6 \times 10^{-6}$	$\pm 1. \times 10^{-8}$ day 1	$\pm 4.6 \times 10^{-6}$
3	$\pm 4.6 \times 10^{-6}$	< 255 slips during first day of holdover	$\pm 4.6 \times 10^{-6}$
4	$\pm 32. \times 10^{-6}$	No holdover	$\pm 32. \times 10^{-6}$

na denotes not applicable.

The Stratum 1 clock has the highest accuracy and is most stable. Normally, lower level clocks are synchronized to a higher level clock and the lower level clocks take on the characteristics of the higher level clock as long as the synchronizing link is working. The lower level synchronized clocks are said to be traceable to a Stratum 1 clock. Should the synchronizing link fail, the lower level clocks would revert to their normal characteristic specifications.

Table 13-2 shows the number of slips expected in holdover with limited temperature variations based on the specifications in GR-1244-CORE.

Table 13-2: Expected Slip Performance in Holdover

Stratum Level	Slips in Day 1	Slips in Week 1
2	1 or less	2
3E	1	22
3	48	919

13.1.3 Primary Reference Source

Strictly speaking, the terms Primary Reference Source (PRS) and Stratum 1 are not synonymous. The two terms may be equivalent if the technology is a cesium beam reference. Two other technologies, LORAN-C and Global Positioning System (GPS), are not autonomous Stratum 1 clocks. However, both the LORAN-C and GPS are synchronized by Stratum 1 clocks and, as explained in Section 13.1.2, take on the characteristics of a Stratum 1 clock. That is, they are traceable to a Stratum 1 clock.

Thus all Stratum 1 clocks are a PRS but not all PRSs are Stratum 1 although they may act like a Stratum 1 if traceable to a Stratum 1. The term PRS in this publication either will mean a clock that is a Stratum 1 clock or is traceable to a Stratum 1 clock.

Further information may be found in GR-436-CORE and ANSI T1.101-1994.

13.1.4 QWEST Synchronization Network

QWEST has one or more PRSs in each Local Access and Transport Area (LATA). The PRS may be any of the technologies discussed in Section 13.1.3.

The majority of, but not all, QWEST wire centers have a BITS clock. The Composite clock or DS1 clock signals are available only in wire centers having a BITS clock.

Each BITS clock is typically a Stratum 2, Stratum 3E or Stratum 3 clock with the higher Stratum levels in the larger wire centers. The BITS clock is traceable to two redundant PRSs. Thus, if one link is lost, Stratum 1 traceability will be maintained by the alternate link. These BITS clocks are the same clocks used by QWEST to synchronize their own network elements including digital test equipment.

Figure 13-1 illustrates a typical QWEST BITS clock arrangement.

The QWEST network meets the requirements of ANSI T1.105.09-1996, *Synchronous Optical Network (SONET): Network Element Timing and Synchronization*, for SONET applications.

13.1.5 Customer Requirements

All Interconnector Designated Equipment (IDE) which requires synchronization must have an internal clock to maintain service for short periods of time in the unlikely event that the synchronizing link to the BITS clock is lost. Most telecommunications equipment has this function available. D-banks, for example, normally come with a Stratum 4 clock that can be externally synchronized from the BITS clock.

GR-436-CORE, Chapter 10, contains information on synchronization criteria for network elements.

Some IDE requires primary and secondary timing signals as indicated in Figure 13-1. The Interconnector should notify QWEST of these requirements when ordering the clock signals so that they can be provisioned using separate TSG equipment if available. This diversity will provide improved availability.

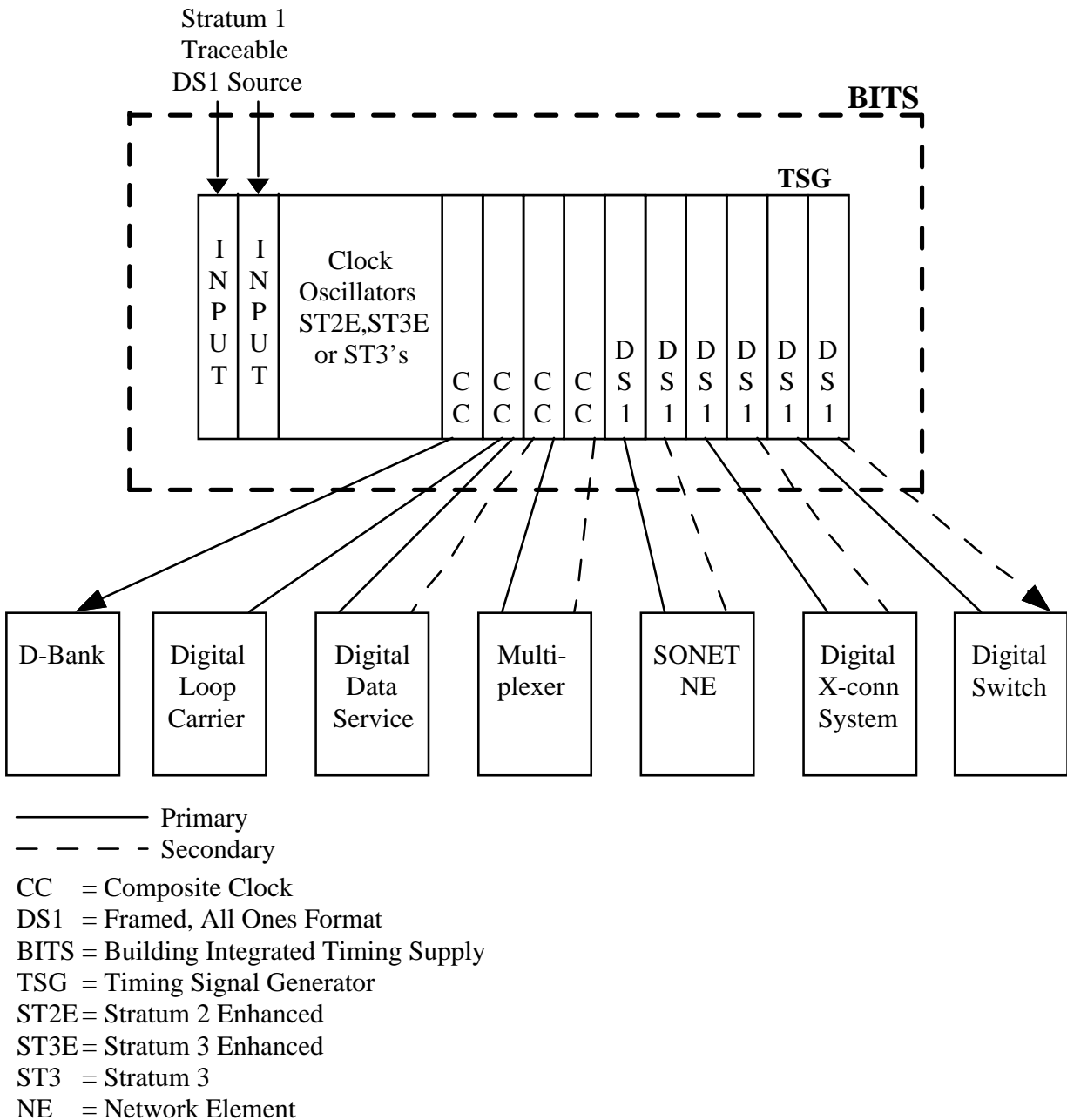

Figure 13-1: Typical QWEST BITS Arrangement

A customer intending to use the synchronization signals to time their own networks should consult Chapter 8 of GR-436-CORE. Most synchronization interfaces between networks are done in Plesiochronous Operation. However, if the customer chooses to use the QWEST BITS clock as a timing source for their own network, some special considerations are necessary.

Interconnectors need to determine their synchronization requirements based on their IDE, the connected QWEST-provided facility or service, and the requirements of the service being transported. The number and type of clock leads will vary with the situation.

13.2 Composite Clock Signal

A composite clock signal is a 64 kHz, nominal 5/8-duty-cycle, bipolar return-to-zero signal with a bipolar violation every eighth pulse. The existing network terminals (e.g., channel banks) with DS0 inputs do not have buffer storage to maintain byte synchronization variations as they are at the DS1 inputs. Thus, these variations are accommodated by requiring that signals at all DS0 level interconnections must be synchronized by a single composite clock source.

Figure 13-2 illustrates a bipolar signal aligned with the Composite Clock Signal. Data is transmitted at the leading edge (#1) of the bit clock and sampled at the trailing edge (#2) of the bit clock.

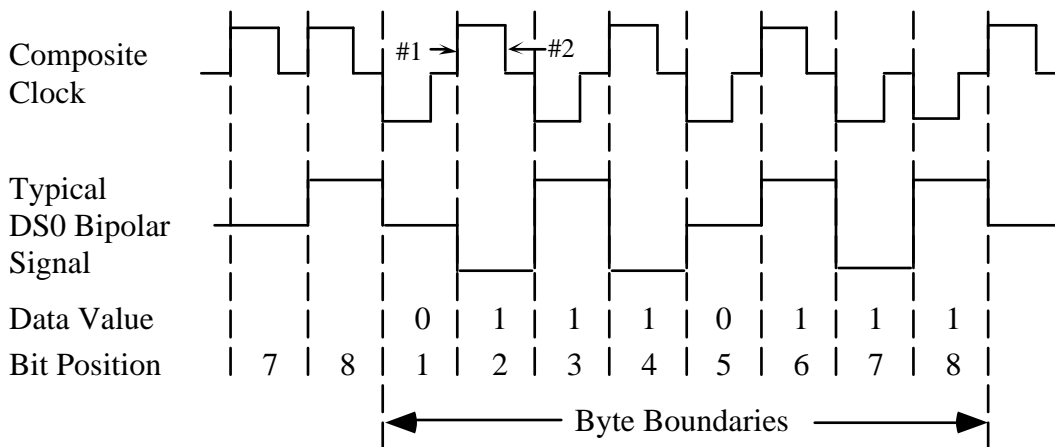

Notes:

1. Data clocked out on this edge.
2. Data sampled on this edge.

Figure 13-2: DS0 and Composite Clock Signal Timing

Figure 13-3 illustrates the composite clock signal. Every eighth pulse violates the bipolar rule. The basic waveform provides the bit clock information while the bipolar violation provides the byte clock information.

The distance between the composite clock and both the Collocated Interconnector's and QWEST's channel banks must not exceed 1500 feet. This rigidly defined maximum is based on propagation times rather than attenuation. The 1500-foot maximum controls transmission delays to ensure that bit transitions at the receiving point will not overlap the local clock sampling instants.

Further information about the composite clock signal may be found in GR-378-CORE.

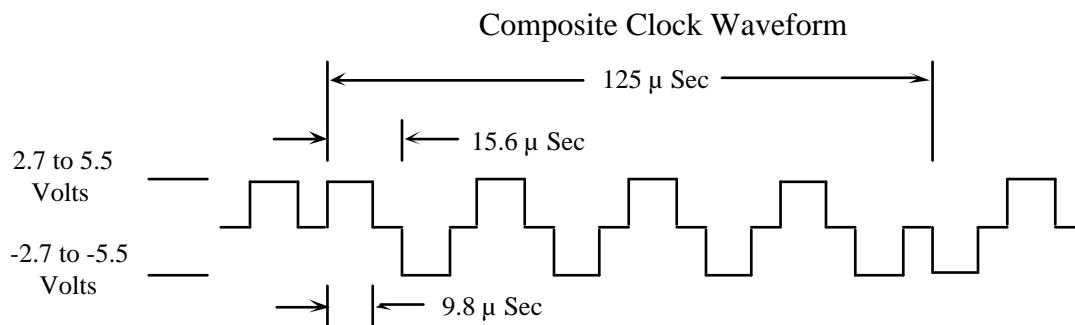

Figure 13-3: Composite Clock Waveform

13.3 DS1 Clock Signal

The DS1 clock signal is a framed, all-ones, 1.544 Mbit/s (DS1) signal using the superframe frame format and Alternate Mark Inversion line code. The signal is similar to the DS1 Rate Synchronization Interface described in PUB 77375. The primary difference is that it is available in the central office and obtained from the BITS clock rather than from the SONET envelope at a customer's premises. This DS1 signal will be delivered to a DSX-1 panel mounted in the Collocated Interconnector's bay.

PUB 77375 should be consulted for further information.

13.4 Virtual Collocation Applications

Synchronization is always required for Virtual Collocation involving digital services or connections. Synchronization may be required for analog services depending on the IDE involved. Synchronization for DS0 level digital connections (e.g., for DDS) must be obtained from QWEST. Synchronization for other digital connections may be obtained from QWEST or from another source as long as the synchronization source is traceable to a Stratum 1 clock.

13.5 Physical Collocation Applications

Synchronization may be required with Physical Collocation depending on the situation. Connections at the DS1 or higher levels will normally require that at least frequency synchronization be provided. The equipment involved normally includes buffers so that phase synchronization is not required.

Digital connections at the DS0 level will require both frequency and phase synchronization if synchronization is required. Connections of analog voice channels may require synchronization depending on the available facility.

There are two alternatives available to an Interconnector for “DS0” level connections such as found with DDS or other DS0 level connections. They are:

- Direct connection to a metallic loop suitable for analog or digital services and
- Connection to other facility types.

QWEST reserves the right to determine the availability of the alternatives in each situation.

13.5.1 Digital Connections to Metallic Loops for DS0 Digital Service

This application applies only for services that use a metallic loop without any electronic equipment. Chapter 10 discusses DDS applications. This alternative does not apply if the QWEST-provided facility or service uses any electronic equipment.

Under these circumstances, no synchronization is required.

The QWEST-provided facility will be designed according to the specifications of the purchased service.

13.5.2 Digital Connections to Other Facilities for DS0 Digital Service

This application applies when QWEST-provided facility uses electronic equipment. Typical situations may include DDS (Chapter 10) or any other digital service that uses electronic equipment including Digital Loop Carrier (DLC) systems or interoffice transport.

Under these circumstances, synchronization is required to properly synchronize the IDE and QWEST equipment.

The QWEST-provided facility will be designed according to the specifications of the purchased service.

13.5.3 Voice Connections to Metallic Loops for Analog Service

Synchronization is not required for analog connections to a QWEST-provided metallic facility.

The QWEST-provided facility will be designed according to the specifications of the purchased service.

13.5.4 Voice Connections to Other Facilities for Analog Service

Analog connections to other QWEST-provided facilities that use electronic equipment (such as DLC) will not require synchronization.

The QWEST-provided facility will be designed according to the specifications of the purchased service. The specific design criteria and selection of IDE are dependent on the specifications of the purchased service and type of QWEST-provided facility.

CONTENTS

Chapter and Section	Page
14. Interconnection to Switched Access Service	14-1
14.1 Switched Access Service Expanded Interconnection-Collocation Termination.....	14-1
14.2 Switched Access Service -- General Description	14-1
14.3 Switched Transport.....	14-1
14.4 Network Interfaces	14-1

14. Interconnection to Switched Access Service

14.1 Switched Access Service Expanded Interconnection-Collocation Termination

The Switched Access Service Expanded Interconnection-Collocation Termination (EICT) rate element provides for the communications path between the Interconnector Designated Equipment (IDE) and a QWEST Switched DS1 or DS3 Transport Service within the same wire center.

The QWEST Switched Access Service is described in PUB 77203, *QWEST Switched Access Service*, in the Federal Communications Commission Tariff Number 5 (FCC #1), Part 6, and in appropriate state tariffs.

14.2 Switched Access Service -- General Description

Switched Access Service, which is available to customers for their use in furnishing their services to End-Users, provides a two-point electrical communications path between a customer's premises and an End-User's premises. It provides for the use of terminating, switching, transport facilities and common subscriber plant of QWEST. Switched Access Service provides for the ability to originate calls from an End-User's premises to a customer's premises, and to terminate calls from a customer's premises to an End-User's premises in the Local Access and Transport Area (LATA) where it is provided.

14.3 Switched Transport

Switched Transport provides the transmission facilities between the customer's premises and the End Office switch(es) where the customer's traffic is switched to originate or terminate its communications.

14.4 Network Interfaces

PUB 77203 discusses the DS1 and DS3 network interfaces, Interface Group 6 and Interface Group 9, respectively. The appropriate tariffs include additional information.

The network interfaces at the Point of Termination (POT) bay or cross-connect frame use Network Channel Interface (NCI) codes of the "DS" type. DS1 NCI codes may include 04DS9.15, 04DS9.15B or 04DS9.15S. DS3 NCI codes may include 04DS6.44. Chapters 8 and 9 contain further information on DS1 and DS3 respectively.

The list of NCI codes and their described interfaces may be modified if Section 21 of FCC #1 (or similar circumstances under other jurisdictions) is used to order Switched Access Service. See Section 16.5 in this publication for further information

**Chapter and Section Were Deleted
In Issue "I"**

CONTENTS

Chapter and Section	Page
16. Interconnection with Finished Services	16-1
16.1 General.....	16-1
16.2 Wire Center Arrangement	16-2
16.3 Point of Termination Network Interfaces.....	16-4
16.4 Design and Provisioning Responsibilities with Finished Services	16-4
16.5 Expanded Interconnection - Collocation (EIC) in FCC #1, Section 21	16-5
16.5.1 Comparison of Section 21 and Other Finished Services.....	16-5
16.5.2 Services Available with EIC	16-6
16.5.3 Virtual EIC Service.....	16-6
16.5.4 Expanded Interconnection Channel Termination (EICT)	16-7
16.5.5 Analog EICT	16-8
16.5.6 Digital Data EICT	16-8
16.5.7 DS1 EICT	16-9
16.5.8 DS3 EICT	16-9
16.6 InterConnect Tie Pair (ITP).....	16-9
16.6.1 General.....	16-9
16.6.2 DS1 ITP	16-9
16.6.3 DS3 ITP	16-10
16.6.4 Optical ITP	16-11
16.6.5 DS1 and DS3 ITPs Ordered from State Tariffs.....	16-11
16.7 EICTs and ITPs Ordered from State Tariffs, Catalogs or Contracts....	16-11
16.8 Direct Connection	16-12
16.9 Summary of DS1 and DS3 Finished Service NCI Code Usage.....	16-12

Figures

16-1 Typical Wire Center Arrangement for Finished Services	16-3
16-2 FCC #1, Section 21 EICT/ITP Arrangement.....	16-7

Tables

16-1 Typical Finished Services Available with EICTs and ITPs	16-6
16-2 Summary of DS1 and DS3 EICT and ITP Network Interfaces	16-12

16. Interconnection with Finished Services

16.1 General

Competitive Local Exchange Carriers (CLECs) may order Finished Services from Qwest. These services may be delivered to their collocation area in the Qwest wire center. These Finished Services are ordered from the appropriate tariff, catalog, or contract and are described in the appropriate technical publication(s) identified in the tariff or catalog.

There are some special issues relating to Collocation ordered from Federal Communications Commission (FCC) Tariff #1, Section 21 and most state tariffs. These special issues have the greatest impact on DS1 and DS3 Finished Services or services that have DS1 or DS3 Network Interfaces (NIs). These special issues are described in Sections 16.5 and 16.6.

Material in this chapter supplements the technical publications for the specific Finished Services.

The CLEC must have some form of Physical or Virtual Collocation in the wire center to have a Finished Service delivered to them within the wire center. That is, the CLEC must have equipment collocated in the wire center. The Physical or Virtual Collocation space may take any form described in Chapter 4.

The Interconnector Designated Equipment (IDE) may be complex and varied as described in Chapter 2. Alternatively, the IDE may be much simpler if the CLEC intends to only connect Finished Services to Unbundled Network Elements (UNEs) or other Finished Services via their equipment. In the latter situation, the IDE may consist of any terminating equipment required by the Finished Service plus cables and cross-connects to connect the service to a UNE or to another Finished Service via the IDE.

The Finished Service will be delivered to a NI located at a Point of Termination (POT). The POT will be located either:

- 1) On the Standard (shared) InterConnection Distribution Frame (ICDF) or
- 2) On a DC-POT in the CLEC's collocation area.
- 3) On a DC-POT outside the CLEC's collocation area on a.

The CLEC must indicate which of the options they wish when they fill out the Collocation Order Forms.

16.2 Wire Center Arrangement

Figure 16-1 illustrates a typical arrangement. This illustration shows several items described in Chapters 2 through 4. Included are:

- A Fiber Entrance Facility
- Some IDE
- Metallic cables to a DS0/Voice, DS1 or DS3 ICDFs
- Fiber cables to a fiber ICDF
- The POT for the termination of Finished Services

The POT may or may not be in the collocation area. As part of its the collocation pre-provisioning process, the Collocator/CLEC has the option of choosing whether the POT is located inside or outside their collocation area. Not all of these elements will apply in every installation. Finished Services may or may not traverse the ICDF. Chapter 3 of this publication describes Direct Connection. This tie cabling option deliberately bypasses the ICDF for both Finished Services and UNEs.

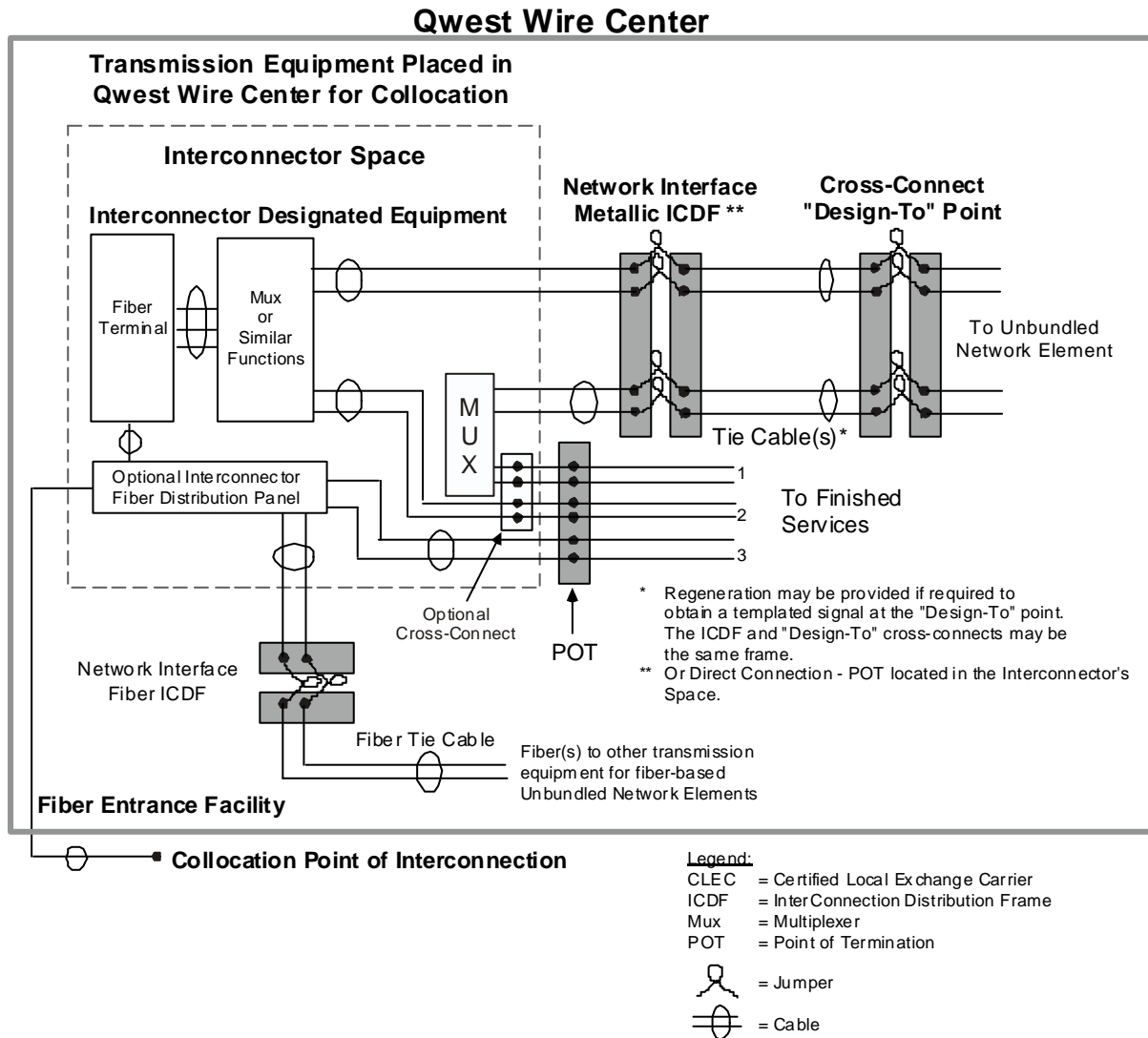

Figure 16-1: Typical Wire Center Arrangement for Finished Services

The CLEC must provide space to mount the termination equipment in their collocation area if they choose to establish their NI inside collocation space. The space requirement will vary with the type of service and NI ordered. The equipment to be placed in this space may be a jack, terminal block, DSX panel, Fiber Distribution Panel or other type of equipment. The technical publication describing the specific Finished Service should be consulted for further information about the NI.

16.3 Point of Termination Network Interfaces

The technical publications, tariffs or catalogs describing Qwest Finished Services may not specifically include CLECs. For purposes of selecting NIs when CLECs are not included, the CLEC (a Carrier) will be treated the same as an Interexchange Carrier (IC). Exceptions to this guideline for DS1 and DS3 NIs are listed later in this chapter.

Therefore, all NIs available to an IC are also available (where technically feasible) to a CLEC unless otherwise excluded by this chapter, other technical publications, tariffs, catalogs or regulatory order. Network Channel Interface (NCI) Codes available at an IC-POT would also be available at the POT in the wire center.

This assumption should be followed until the technical publication, tariff or catalog is revised to include the CLEC as a separate type of customer.

The CLEC may order a standard telephone line (a Finished Service) to their space for their own use. The CLEC in this situation is an End-User. The line will be installed in compliance with the appropriate state exchange tariff.

NIs typically include some form of connecting block or cross-connect panel provided by Qwest (which may be the same connecting block or cross-connect panel used by Qwest). In situations where the block or panel is physically located in a CLEC's cage or cageless area and for their sole use, the CLEC has the option of providing the equivalent block or panel. This alternative may be limited by another technical publication, tariff, contract or regulatory order.

It is recommended that Qwest provide the block or panel. Should the CLEC opt to provide the block or panel, they must arrange with Qwest concerning the termination of cables by Qwest on the block or panel.

If the CLEC provides the panel for DS3 Finished Services, the SJA44 connector described in PUB 77324 must be of the BNC type.

Qwest requires access to the NI for installation, testing and ongoing maintenance.

16.4 Design and Provisioning Responsibilities with Finished Services

Qwest will design, install and maintain the Finished Service as defined in the appropriate tariff, catalog, contract or technical publication. Some exceptions to these definitions are discussed in Section 16.5. The service will be delivered to the POT as previously defined. Qwest will maintain records of the service.

The CLEC has the responsibility of designing, installing and maintaining all facilities and equipment on their side of the POT. The CLEC will maintain any records they require for these facilities and equipment.

The CLEC has end-to-end responsibility for the service sold to their customer and ordering the appropriate Finished Service(s) from Qwest.

16.5 Expanded Interconnection - Collocation (EIC) in FCC #1, Section 21

Finished Services may be purchased from several tariffs. Section 21 of FCC #1 describes a Finished Service version of Expanded Interconnection - Collocation (EIC) that may differ from other Finished Services, Unbundled Network Elements and some collocation requirements described in other chapters of this document. EIC is described in this section. Section 21 should be consulted for further information.

Contracts may also support EIC as described in Section 2.1. The descriptive material in this chapter also applies except as stated in the contract.

16.5.1 Comparison of Section 21 and Other Finished Services

Normal Finished Services of the Private Line Transport Service (PLTS) variety typically consist of two segments from the Qwest wire center(s) out to the customer premise(s). An additional segment may also connect two wire centers if the PLTS is a multi-wire center service. PLTSs of this type ordered from Section 7 of FCC #1 are normally charged for two Channel Termination charges plus other charges as appropriate. Some configurations would only be charged one Channel Termination charge.

Due to the special nature of Finished Services ordered from FCC #1 which stop in the Qwest wire center for purposes of connecting to a CLEC's IDE, a new channel termination charge was developed to recognize the shorter distances and reduced costs. This new type of channel termination is called an Expanded Interconnection Channel Termination (EICT). The EICT charge will replace one of the Channel Termination charges normally charged for the PLTS. A variation called an InterConnect Tie Pair (ITP) is described in Section 16.6.

The EICT may have NIs that are different than those found with a traditional Finished Service. This section describes the EICT NIs. The technical parameters of the channel may be different from the traditional Finished Service because of the different NIs.

The following DS1 and DS3 EICT descriptions may also apply to DS1 and DS3 Finished Services ordered from other tariffs or catalogs.

16.5.2 Services Available with EIC

EIC is available with certain specific Finished Services sold in FCC #1. Other services may be included when ordered out of other tariffs, catalogs or Interconnection Agreements. Table 16-1 lists some typical services. The list is not an all-inclusive list.

16.5.3 Virtual EIC Service

Section 21 of FCC #1 also describes Virtual EIC Service. Consult the tariff for general information. Other information about Virtual Collocation may be found in Chapter 4 of this publication.

Table 16-1: Typical Finished Services Available with EICTs and ITPs

EICT & ITP **	Finished Service ***	Technical Publication
Analog	Low Speed Data (LS1 and LS2) Telegraph/Teletypewriter (TG1 and TG2) Direct Current Service (MT3) Voice Grade Access Enhanced Extended Loop (EEL)	PUB 77307 PUB 77307 PUB 77307 PUB 77310 PUB 77403
Digital Data	Qwest Digital Data Service Frame Relay Service (FRS)	PUB 77204 PUB 77312 PUB 77372 *
DS1	Qwest DS1 Service Frame Relay Service (FRS) Switched Access Service, Switched Transport, etc. MegaCentral Service Local Interconnect Service /E911/CCSAC(LIS) Enhanced Extended Loop (EEL)	PUB 77200 PUB 77375 PUB 77372 * PUB 77203 * PUB 77392 PUB 77398 PUB 77403
DS3	Qwest DS3 Service Frame Relay Service (FRS) Switched Access Service, Switched Transport, etc. MegaCentral Service Local Interconnect Service /E911/CCSAC(LIS) Enhanced Extended Loop (EEL)	PUB 77324 PUB 77372 * PUB 77203 * PUB 77392 PUB 77398 PUB 77403
Optical	Synchronous Service Transport (SST) Self-Healing Network Service (SHNS) Self-Healing Alternate Route Protection (SHARP) ATM Cell Relay GeoMax Metro Optical Ethernet (MOE)	PUB 77346 PUB 77332 PUB 77340 PUB 77378 PUB 77407 PUB 77411

* Also discussed in this publication: FRS - Chapter 11, Switched - Chapter 14.

** See Section 16.6.

*** Other Finished Services may be available. See the appropriate tariff, catalog or contract for further information.

16.5.4 Expanded Interconnection Channel Termination (EICT)

Table 16-1 identifies five types of EICT and the types of services to which they may be connected. These EICTs are described in the following sections. Appropriate NCI codes are included. Similar EICT rate elements may be found in other tariffs, catalogs or contracts that apply to additional services.

Figure 16-2 illustrates a typical PLTS Finished Service with EICT arrangement. The service provides a channel from a NI at the CLEC end, through Qwest's network, and on to the NI at the other end. The EICT rate element represents the cable and any other equipment items located between the NI with the CLEC and the last cross-connect frame in the Qwest network.

Example of Private Line Transport Service Illustrating an Expanded Interconnection Channel Termination (EICT)

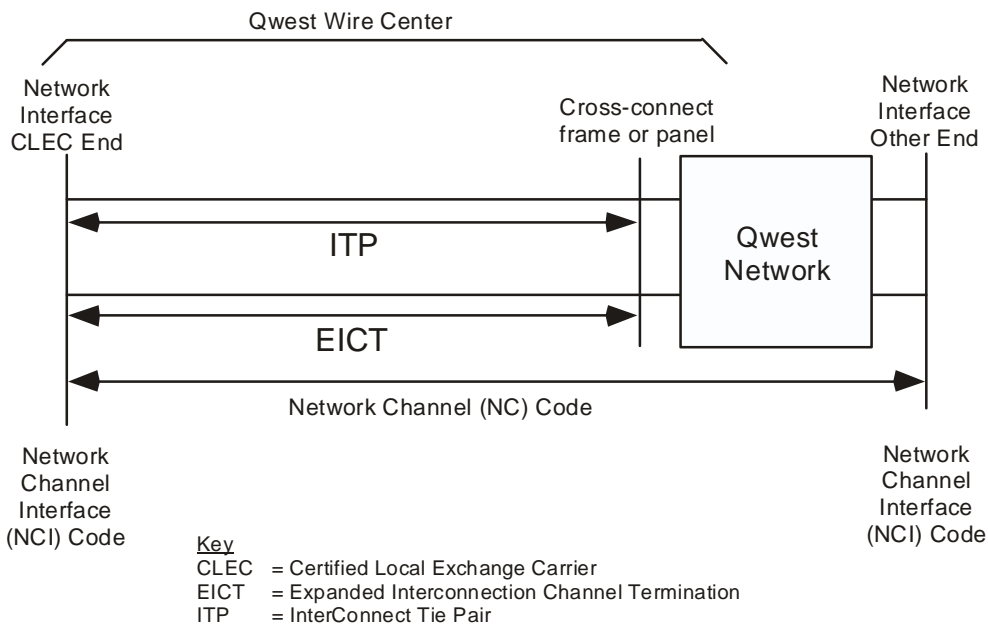

Figure 16-2: FCC #1, Section 21 EICT/ITP Arrangement

Both NIs are represented by NCI codes. The PLTS channel is represented by a NC code. These codes are used to order the PLTS.

The NI at the CLEC end usually has a connecting block or some form of cross-connect panel as the physical NI. Some jurisdictions permit the CLEC to supply this device.

As discussed in Section 16.5.1, the EICTs described in this section may apply to Finished Services not listed in Table 16-1. The appropriate technical publication should be consulted for information about these services. Some descriptions may have to be modified as discussed later in this section.

16.5.5 Analog EICT

The Analog EICT is used with analog Finished Services such as those identified in Table 16-1.

Voice Grade PLTS is described in PUB 77310. The columns titled "Interconnector" in the NC/NCI Combination tables of PUB 77310 identify the valid NCI codes for each NC code. See the publication for further information.

PUB 77307 identifies the applicable NCI codes for the Low Speed Data and Telegraph/Teletypewriter Services. The NCI codes at the IC-POT should be used.

The only valid NCI code at the CLEC end for Direct Current Service is 02QC8.DC3. This NCI code is defined as *Central Office Manual Cross-Connect DS0/Voice Termination, Direct current or voltage for DC/Low Frequency Control Signals or Low Speed Data (30 Baud). These options can be provided on derived facilities.* See the technical publication and the tariff for further information.

16.5.6 Digital Data EICT

The Digital Data EICT is used with the Qwest Digital Data Service (DDS) described in PUBs 77204 and 77312 and Frame Relay Service described in Chapter 11 and PUB 77372.

DDS is described in PUB 77204. The columns titled "CLEC NI" in the NC/NCI Combination tables of PUB 77204 identify the valid NCI codes for each NC code. The NCI codes applicable to the Digital Data EICT are the codes starting with 04DO5. These NCI codes are described in PUB 77312. See the publications for further information.

The NCI codes for Frame Relay service for the Digital Data EICT are at the 56 kbit/s and 64 kbit/s rates only. The valid CLEC end NCI codes are 04DO5.E for 56 kbit/s and 04DO5.F at 64 kbit/s. These NCI codes are described in PUB 77312.

The 04DO5 NI requires same-source synchronization to operate properly. CLECs must purchase synchronization as described in Chapter 13.

16.5.7 DS1 EICT

The DS1 EICT is available with the services such as those identified in Table 16-1. The table also lists the publications describing the services. The DS1 EICT normally uses a templated DSX-1 signal using the NCI code of the type 04DS9. This EICT includes the regenerator required to provide the templated signal. See the listed publication for further information.

16.5.8 DS3 EICT

The DS3 EICT is available with the services such as those identified in Table 16-1. The table also lists the publications describing the services. The DS3 EICT normally uses a templated DSX-3 signal using the NCI code of the type 04DS6. This EICT includes the regenerator required to provide the templated signal. See the listed publication for further information.

16.6 InterConnect Tie Pair (ITP)

16.6.1 General

There may be instances where a DS1 or DS3 NI does not require a templated signal. That is, the CLEC's IDE is within the maximum distance from the last DSX panel in the Qwest network (Figure 16-2).

This is accomplished by ordering an InterConnect Tie Pair (ITP) tariff rate element from a tariff or contract instead of an EICT rate element.

There are no ITPs at the DS0/voice level since regeneration is not an issue and there are no opportunities for cost reduction.

The NC and NCI codes at the other end of the PLTS are described in the appropriate technical publications when using the ITP. The NIs (and their respective NCI codes) at the CLEC end of the PLTS are described as follows.

16.6.2 DS1 ITP

The DS1 ITP is available from FCC #1, Section 21 with the DS1 services identified in Table 16-1. The table also lists the publications describing the services. The service is also available as identified in approved Interconnection Agreements. Other tariffs and catalogs may identify other services and their respective technical publications.

However, these publications do not describe the NI at the CLEC end of the ITP. This NI is described here.

The valid NCI codes for the CLEC's end of the DS1 ITP is 04QB9.11. This code is described in Table 6-5.

Specifically, the NI does not normally provide DS1 signal levels as specified by GR-342-CORE (i.e., a templated signal). That is, the 04QB9.11 NI is **not** a 04DS9-type of NI. Further information about 04DS9-type NCI codes may be found in PUB 77375.

One exception to this would be if the CLEC chooses to use the DS1 ICDF as the NI **and** the ICDF is a DSX-1 with a DSX-1 templated signal (i.e., the ICDF is also the "Design-To" Point). If both of these requirements are met, the ITP and EICT are technically identical.

In this application (Figure 16-1), the last cross-connect in the Qwest network is a DSX-1 cross-connect which has a templated signal. The 04QB9.11 NCI denotes that the templated signal at the DSX-1 is attenuated by the length of the cable represented by *ITP* in the figure.

The cable will be shielded, paired cable. The *ITP* will use the type of cable (i.e., 22, 24 or 26-gauge shielded cable) that most nearly permits connections to IDE without the need for a regenerator. The CLEC has the responsibility to determine if their IDE equipment will properly operate with a non-templated signal.

However, if the CLEC wishes to place a DSX-1 in their collocation space between the ITP and their IDE, a regenerator will be required if they wish to achieve a templated signal at their DSX-1.

16.6.3 DS3 ITP

The DS3 ITP is available from FCC #1, Section 21 with the DS3 services identified in Table 16-1. The table also lists the publications describing the services. The service is also available as identified in approved Interconnection Agreements. Other tariffs and catalogs may identify other services and their respective technical publications.

However, these publications do not describe the NI at the CLEC end of the ITP. This NI is described here.

The valid NCI codes for the CLEC's end of the DS3 ITP is 04QB6.33. This code is identified in Table 6-5.

Specifically, the NI does not normally provide DS3 signal levels as specified by GR-342-CORE (i.e., a templated signal). That is, the 04QB6.33 NI is **not** a 04DS6-type of NI. Further information about 04DS6-type of NCI codes may be found in PUB 77324.

One exception to this would be if the CLEC chooses to use the DS3 ICDF as the NI **and** the ICDF is a DSX-3 with a DSX-3 templated signal (i.e., the ICDF is also the "Design-To" Point). If both of these requirements are met, the ITP and EICT are technically identical.

In this application (Figure 16-1), the last cross-connect in the Qwest network is a DSX-3 cross-connect which has a templated signal. The 04QB6.33 NCI denotes that the templated signal at the DSX-3 is attenuated by the length of the cable represented by *ITP* in the figure.

The cables will be coaxial cables. The ITP will use the type that most nearly permits connections to IDE without the need for a regenerator. The CLEC has the responsibility to determine if their IDE equipment will properly operate with a non-templated signal.

While most installations will not require regeneration to reach IDE locations, there may be instances where distances are exceeded. If the CLEC wishes to place a DSX-3 (in their collocation space) between the ITP and their IDE, a regenerator will be required if they wish to achieve a templated signal at their DSX-3.

16.6.4 Optical ITP

The Optical ITP is available from FCC #1, Section 21 with the Optical services identified in Table 16-1. The table also lists the publications describing the services. The service is also available as identified in approved Interconnection Agreements. Other tariffs and catalogs may identify other services and their respective technical publications..

The valid NCI codes for the CLEC's end of the Optical ITP are 04QBF.LL and 02QBF.LL. These codes are described in Table 6-5.

The valid NCI codes for the CLEC's end of an Optical ITP when Ethernet is required is 02QBF.LLX, see Table 6-5.

16.6.5 DS1 and DS3 ITPs Ordered from State Tariffs

Finished Services ordered from state tariffs also use ITPs. Some tariffs may still call them EICTs. The state tariffs do not distinguish the use or lack of regeneration by name as the FCC tariff does.

The DS1 and DS3 ITPs with regeneration are identical to the DS1 and DS3 EICTs as described in Sections 16.5.7 and 16.5.8 respectively.

The DS1 and DS3 ITPs without regeneration are identical to the DS1 and DS3 ITPs as described in Sections 16.6.2 and 16.6.3 respectively.

16.7 EICTs and ITPs Ordered from State Tariffs, Catalogs or Contracts

Some interconnection agreements, state tariffs or catalogs use EICTs and ITPs in a manner similar to the FCC applications described in the previous section. Unless the specific interconnection agreement, state tariff or catalog describes the EICTs or ITPs differently, the EICTs will be as described in Section 16.5.4 through Section 16.5.9. The ITPs will be as described in Section 16.6. Some descriptions may differ only by name.

These interconnection agreements, state tariffs or catalogs may involve services not included in the FCC tariff. However, the EICT and ITP descriptions should apply at the appropriate level.

The specific agreement should be consulted for further information concerning EICTs and ITPs purchased from an agreement.

16.8 Direct Connection

A CLEC that wants a guarantee that a Finished Service never goes through two successive cross-connect frames via a tie cable must order a Direct Connection arrangement as described in Chapter 3. The CLEC may choose any of the Direct Connection options described in Chapter 3. This tie cable may be either repeatered or non-repeatered.

16.9 Summary of DS1 and DS3 Finished Service NCI Code Usage

Table 16-2 summarizes the available NIs and their NCI codes for DS1 and DS3 EICTs and ITPs used with Finished Services and UNEs at a collocation site. The NCI codes at the other end of the transport service are as described in the appropriate technical publication.

Table 16-2: Summary of DS1 and DS3 EICT and ITP Network Interfaces

Application Type	With Regeneration	Element Name	NCI Codes	
			DS1	DS3
FCC Finished Service	Yes	EICT	04DS9.xxx *	04DS6.xxx *
	No	ITP	04QB9.11	04QB6.33
State Finished Service	Yes	ITP	04DS9.xxx *	04DS6.xxx *
	No	ITP	04QB9.11	04QB6.33
UNE	Yes	ITP	04QB9.11R	04QB6.33R
	No	ITP	04QB9.11	04QB6.33

* The x's denote positions for several option codes. See the appropriate technical publication for further details.

CONTENTS

Chapter and Section	Page
17. Definitions.....	17-1
17.1 Acronyms.....	17-1
17.2 Glossary.....	17-3

17. Definitions

17.1 Acronyms

AC	alternating current
AMI	Alternate Mark Inversion
ANSI	American National Standards Institute
ATM	Asynchronous Transfer Mode
B8ZS	Bipolar with 8 Zero Substitution
BDFB	Battery Distribution Fuse Board
BPRZ	Bipolar Return to Zero
CEV	Controlled Environmental Vault
CLEC	Competitive Local Exchange Carrier
CLLI™	COMMON LANGUAGE® Location Identification
CO	Central Office
COCC	Central Office Connecting Channel
COSMIC®	Common System Main Interconnecting Frame
CPOI	Collocation Point of Interconnection
DC	Direct Current
DC-POT	Direct Connection - Point of Termination
DCS	Digital Cross-Connect System
DDS	Digital Data Service
DID	Direct Inward Dialing
DOD	Direct Outward Dialing
DS0	Digital Signal Level 0 (64.0 kbit/s)
DS1	Digital Signal Level 1 (1.544 Mbit/s)
DS3	Digital Signal Level 3 (44.736 Mbit/s)
DSX-0	Digital Signal Level 0 Cross-connect
DSX-1	Digital Signal Level 1 Cross-connect
DSX-3	Digital Signal Level 3 Cross-connect
DTMF	Dual Tone MultiFrequency

EICT	Expanded Interconnection Channel Termination
ESF	Extended Super Frame
FCC	Federal Communications Commission
FDP	Fiber Distribution Panel
GPS	Global Positioning System
HDSL	High-bit-rate Digital Subscriber Line
Hz	1 Hertz (formerly 1 cycle per second)
IC	Interexchange Carrier
ICDF	InterConnection Distribution Frame
IDE	Interconnector Designated Equipment
IDF	Intermediate Distributing Frame
IntraLATA	IntraLocal Access and Transport Area
ISDN	Integrated Services Digital Network
ITP	InterConnect Tie Pair
LASER	Light Amplification by Stimulated Emission of Radiation
LATA	Local Access and Transport Area
LEC	Local Exchange Carrier
LORAN	LOng RAnge Navigation
Mbit/s	Megabit per Second
MDF	Main Distributing Frame
MELD	Mechanized Engineering Layout for Distributing Frames
MUX	Multiplexer
NC	Network Channel
NCI	Network Channel Interface
NI	Network Interface
nm	nanometer
OC	Optical Carrier
ONA	Open Network Architecture
PBX	Private Branch Exchange

PLAR	Private Line Automatic Ring-down
PLTS	Private Line Transport Service (Special Access)
POI	Point of Interconnection
POT	Point Of Termination
POTS	Plain Old Telephone Service
PRS	Primary Reference Resource
SF	Superframe Format
SONET	Synchronous Optical Network
TLP	Transmission Level Point
UDIT	Unbundled Dedicated Interoffice Transport
UNE	Unbundled Network Element
VEIC	Virtual Expanded Interconnection-Collocation

17.2 Glossary

Active Element

Is an electronic device that changes/manipulates the input signal to create a new output signal (ie. a Multiplexer (Mux.), regenerator, etc.).

Alternate Mark Inversion (AMI)

A one (mark) pulse which is the opposite polarity as its predecessor.

American National Standards Institute (ANSI)

An organization supported by the telecommunications industry to establish performance and interface standards.

Asynchronous Transfer Mode (ATM)

An information transfer method in which the information is organized into fixed length (53 octet) cells. It is asynchronous in the sense that the recurrence of cells containing user information is not necessarily periodic.

Asynchronous Transmission

Not synchronous: Data transmission in which the time of occurrence of specified significant instant of a data bit (usually the leading edge) is arbitrary, and occurs without necessarily having a fixed time relationship to preceding comparable instants.

Azimuth

The angle between horizontal reference direction and the horizontal of the direction of bore sight of the antenna.

Baud

A unit of signaling speed. It is the reciprocal of the time duration in seconds of the shortest signal element (binary 1 or 0) within a code signal. The rates specified are the number of signal elements per second.

Bipolar Violation (BPV)

An unexpected violation (not a predetermined signature) of the Bipolar Alternate Mark Inversion (AMI) line-code rule. A violation is declared for AMI if two successive pulses have the same polarity if the bipolar violation is not part of an intentional byte used for special control, e.g. BnZS.

Bipolar With 8 Zero Substitution (B8ZS)

Bipolar 8 Zero Substitution is an application of BPRZ and is an exception to the Alternate Mark Inversion (AMI) line-code rule. It is one method of providing bit independence for digital transmission by providing a minimum 1s density of 1 in 8 bits.

Bit (Binary Digit)

A binary unit of information. It is represented by one of two possible conditions, such as the value 0 or 1, on or off, high potential or low potential, conducting or not conducting, magnetized or demagnetized. A Bit is the smallest unit of information, by definition.

Carrier

An organization whose function is to provide telecommunications services. Examples are: Local Exchange Carriers, Interexchange Carriers, Cellular Carriers, etc.

Central Office (CO)

A local switching system used to provide Telecommunications Services, including, but not limited to:

1. End Office Switches - which are used to terminate end user station loops, or equivalent, for the purpose of interconnecting to each other and to trunks; and
2. Tandem Office Switches - which are used to connect and switch trunk circuits between and among other End Office Switches. CLEC switch (es) shall be considered Tandem Office Switch (es) to the extent such switch (es) actually serve (s) the same geographic area as Qwest's Tandem Office Switch or is used to connect and switch trunk circuits between and among other Central Office Switches. Access tandems typically provide connections for exchange access and toll traffic, and Jointly Provided Switched Access traffic while local tandems provide connections for Exchange Service (EAS/Local) traffic. CLECs may also utilize a Qwest Access Tandem for the exchange of local traffic as set forth in this Agreement.

Central Office Connecting Channel (COCC)

A tariff rate category which provides for connections, within the same Hub wire center, between the Private Line Transport Channel and other services provided by QWEST. See FCC #1 for more information.

Competitive Local Exchange Carrier (CLEC)

A Local Exchange Carrier certified to do business in a state.

Channel

An electrical or photonic, in the case of fiber optic based transmission systems, communications path between two or more points of termination.

Clear Channel Capability (CCC)

A characteristic of a transmission path in which the bit positions allocated for customer data may represent any combination of zeroes and ones.

Closed End

The end of a switched service which transmits address signals.

Customer Premises

Denotes a building or portion(s) of a building occupied by a single customer or End-User either as a place of business or residence. Adjacent buildings and the buildings on the same continuous property occupied by the customer and not separated by a public thoroughfare are also considered the same customer's premises.

Customers

Denotes any individual, partnership or corporation who subscribes to the services provided by QWEST customers are divided into two distinct and separate categories: (1) carriers, who provide services for hire for others, and (2) end-users, who request services only for their own use.

Decibel (dB)

A unit measurement of transmission loss, gain, or relative level. It is the logarithmic unit of signal power ratio most commonly used in telephony. It is used to express the relationship between two signal powers, usually between two acoustic, electrical, or optical signals; it is equal to ten times the common logarithm of the ratio of the two signal powers.

Digital Cross-Connect System (DCS)

An intelligent (processor controlled) digital terminal that provides the capability to perform electronic cross-connects on digital channels operating at or below the bit rate of the transport systems terminated on the unit. This unit may also provide other features, e.g., bridging.

Digital Loop Carrier

A digital transport facility used to carry circuits or channels on part of all of the loop between the serving wire center and the customer's location. Copper or fiber is normally used as the transport medium.

Digital Hierarchy Level

The level in the digital hierarchy. The levels and the respective bit rates are:

<u>Level</u>	<u>Bit Rate</u>	<u>Level</u>	<u>Bit Rate</u>
DS0	64.0 kbit/s	DS3	44.736 Mbit/s
DS1	1.544 Mbit/s	DS3C	90.52 Mbit/s
DS1C	3.152 Mbit/s	DS4NA	139.264 Mbit/s
DS2	6.312 Mbit/s	DS4	274.176 Mbit/s

Direct Connection - Point of Termination (DC-POT)

A cross-connect, block or panel located in an Interconnector's collocation space within a QWEST wire center that serves as the Network Interface for Unbundled Network Elements purchased from QWEST. The DC-POT is for the sole use of the Interconnector.

Direct Inward Dialing (DID)

The ability for a caller outside a company to call an internal extension without having to pass through an operator or attendant.

Direct Outward Dialing (DOD)

The ability to dial directly from an extension without having to go through an operator or attendant.

Dual tone Multifrequency Signaling (DTMF)

A signaling method that employs signals consisting of two sinusoidal voice frequency components, one from a group of four low frequencies and the other from a group of four high frequencies.

End Office

A designation of a QWEST switching system that occupies the lowest level of the public switched network hierarchy. It is the designation of a switching system that connects lines to lines, and lines to trunks (a local switching system).

End-User

The term "end-user" denotes any customer of telecommunications service that is not a carrier, except that a carrier shall be deemed to be an "end-user" to the extent that such carrier uses a telecommunications service for administrative purposes without making such service available to others, directly or indirectly. The term is frequently used to denote the difference between a Carrier interface and an interface subject to unique regulatory requirements at non-Carrier customer premises (FCC Part 68, etc.)

Exchange

A unit established by QWEST for the administration of communications service in a specified geographic area that usually embraces a city, town, or village and its environs.

Expanded Interconnection Channel Termination (EICT)

A QWEST-provided Channel Termination for the communications path or channel between Interconnector-Designated Equipment (through an interconnection arrangement) and a QWEST private line, switched access or other service or Unbundled Network Element.

Extended Superframe (ESF) Format

An Extended Superframe consists of twenty-four consecutive DS1 frames. Bit one of each frame (the F-bit) is time shared during the 24 frames to describe a 6 bit frame pattern, a 6 bit Cyclic Redundancy Check (CRC) remainder, and a 12 bit data link. The transfer rate of each is 2 kbit/s, 2 kbit/s, and 4 kbit/s respectively.

Facilities

Facilities are the transmission paths between the demarcation points serving customer locations, a demarcation point serving a customer location and a QWEST Central Office, or two QWEST offices.

Frame Relay Access Link

A Frame Relay access channel used to access the designated geographical QWEST Frame Relay Service Serving Area.

Frequency Shift

The change in frequency of a tone as it is transmitted over a channel.

Impedance

The total opposition offered by an electric circuit to the flow of an alternating current of a single frequency. It is a combination of resistance and reactance and is measured in ohms.

Integrated Services Digital Network (ISDN)

A network providing or supporting a range of telecommunications services that provides digital connections between End-Users.

InterConnection Distribution Frame (ICDF)

The generic name for a cross-connect frame(s) designated as the Network Interface between QWEST and a collocated Competitive Local Exchange Carrier or Co-Provider. ICDFs are generally level specific (e.g., DS0/voice, DS1, DS3 or optical). These frames typically serve other purposes and normally will have a more specific name depending on usage in a specific wire center.

Interexchange Carrier (IXC)

Any individual, partnership, association, joint-stock company, trust, governmental entity or corporation engaged for hire in interexchange, interstate or foreign communication by wire or radio.

Kilobit/Second (kbit/s)

One thousand (1000) bits/second

Line

The transport facility (cable pair or carrier channel) between the Central Office and Network Channel Interface.

Line-Side Connection

Denotes a connection of a transmission path to the dial tone side of a switching system.

Line-Type Connection

Denotes a connection between a station at a customers premise and a Central Office (CO). These are connected on the dial tone side of the CO.

Local Access and Transport Area (LATA)

A geographic area for the provision and administration of communications service. It encompasses designated exchanges that are grouped to serve common social, economic and other purposes.

Local Exchange Carrier (LEC)

Any company or corporation engaged for hire in providing Access and intraLATA communications services.

Loop

The facility which connects the Local Wire Center to the customer's location.

Loop Signaling

Loop signaling uses a DC path, or loop, to convey address and supervisory signaling information.

Megabit per Second (Mbit/s)

One million (1,000,000) bits per second

Metallic Facilities

A facility that consists of continuous metallic conductors, i.e., devoid of electronic enhancements that would corrupt Direct Current continuity.

Multiplexer (Mux)

An equipment unit to multiplex, or do multiplexing: Multiplexing is a technique of modulating (analog) or interleaving (digital) multiple, relatively narrow bandwidth channels into a single channel having a wider bandwidth (analog) or higher bit-rate (digital). The term Multiplexer implies the demultiplexing function is present to reverse the process so it is not usually stated.

Network

The interconnected telecommunications equipment and facilities.

Network Channel (NC) Code

The Network Channel (NC) code is an encoded representation used to identify both switched and non-switched channel services. Included in this code set are customer options associated with individual channel services, or feature groups and other switched services.

Network Channel Interface (NCI) Code

The Network Channel Interface (NCI) code is an encoded representation used to identify five (5) interface elements located at a Point of Termination (POT) at a central office or at the Network Interface at a customer location. The Interface code elements are: Total Conductors, Protocol, Impedances, Protocol Options, and Transmission Level Points (TLP). (At a digital interface, the TLP element of the NCI code is not used.)

Network Interface (NI)

The point of demarcation on the customer's premises at which QWEST's responsibility for the provision of service ends.

Ohm

The unit of electric resistance.

Open End

The end of a switched service from which dial tone is drawn.

Optical Carrier (OC)

Optical carrier, the nomenclature for the line rate of the optical transmission signal described in this document.

Optical Interface (OI)

The OI is the transmit point wherein light waves move away from the interface toward an optical receiver.

Point of Termination (POT)

The physical telecommunications interface that establishes the technical interface, the test point(s), and the point(s) of operational responsibility. (See Network Interface).

Premises

Refers to Qwest's central offices and Serving Wire Centers; all buildings or similar structures owned, leased, or otherwise controlled by Qwest that house its network facilities; all structures that house Qwest facilities on public rights-of-way, including but not limited to vaults containing loop concentrators or similar structures; and all land owned, leased, or otherwise controlled by Qwest that is adjacent to these central offices, Wire Centers, buildings and structures.

Private Line Automatic Ringdown (PLAR)

Denotes a two-point or multipoint channel with QWEST (or Interconnector) provided signaling at a serving wire center. Either end of the channel can originate a seizure which will cause a 20 Hz ringing signal to be applied to the remote end until answered. The customer must identify primary and remote stations.

Remote Premises

All Qwest Premises (as defined above), other than Qwest Wire Centers or adjacent to Qwest Wire Centers. Such Remote Premises include controlled environmental vaults, controlled environmental huts, cabinets, pedestals and other remote terminals.

Reverse Battery

The switch, during setup and ringing, places -48v on ring, ground on tip. When the called party goes off-hook, the condition is reversed (i.e., -48v on tip, ground on ring).

Serving Wire Center

The term "Serving Wire Center" denotes a QWEST Central Office from which dial tone for the local Exchange Service would normally be provided to the demarcation point on the property at which the customer is served.

Signaling

The transmission of information to establish, monitor, or release connections and/or provide Network Control.

Signaling Transfer Point (STP)

A signaling point with the function of transferring signaling messages from one signaling link to another and considered exclusively from the viewpoint of the transfer. STPs are stored program control packet switches which are inter-connected with other nodes in the signaling network by digital data links. The STPs perform a switching function to route signaling traffic within the signaling network.

Superframe Format (SF)

A superframe consists of 12 consecutive DS1 frames. Bit one of each frame (the F-bit) is used to describe a 12-bit framing pattern during the 12 frames.

Synchronous Optical Network (SONET)

A standard providing electrical and optical specifications for the physical and higher layers, the first stage of which is at 51.84 Mbit/s, the Optical Channel 1 (OC-1) level. Other rates, defined as

OC-n where n=3 through a number not yet firm, are possible.

Synchronous Transmission

A transmission process such that between any two significant instants in the overall bit-stream there is always an integral number of unit intervals.

Transmission Level Point (TLP)

A point in a transmission system at which the ratio, usually expressed in decibels, of the power of a test signal at that point to the power of the test signal at a reference point, is specified. For example, a zero transmission level point (0 TLP) is an arbitrarily established point in a communication circuit to which all relative levels at other points in the circuit are referred.

Trunk

A communications path connecting two switching systems in a network used in the establishment of an end-to-end connection.

Trunk Group

A set of trunks that are traffic engineered as a unit for the establishment of connections between switching systems in which all of the communications paths are interchangeable.

Trunk-Side Connection

Denotes the connection of a transmission path to the non-dial tone side of a local exchange switching system.

Unbundled Network Element (UNE)

Portions of QWEST's network that have been unbundled or segmented for sale to Competitive Local Exchange Carriers (CLECs). These elements are described in QWEST Technical Publications, tariffs, contracts or other documents. The CLEC may combine the Unbundled Network Element with their equipment and/or other QWEST services or Unbundled Network Elements to provide CLEC-designed services for their customers. The combination of these elements and services may or may not be the same as similar QWEST-designed services. Typical examples include Unbundled Loops and Unbundled Switch Ports.

Voice Grade

A term used to describe a channel, circuit, facility or service that is suitable for the transmission of speech, digital or analog data or facsimile, generally with a frequency range of about 300 to 3000 Hz.

Wire Center

Denotes a building or space within a building that serves as an aggregation point on a given carrier's network, where transmission facilities are connected or switched. Wire Center can also denote a building where one or more Central Offices, used for the provision of Basic Exchange Telecommunications Services and Access Services, are located.

CONTENTS

Chapter and Section	Page
18. References	18-1
18.1 American National Standards Institute Documents.....	18-1
18.2 Telcordia Documents.....	18-1
18.3 QWEST Technical Publications.....	18-2
18.4 Other Publications	18-4
18.5 Ordering Information.....	18-4
18.6 Trademarks	18-5

18. References

This chapter lists the referenced publications discussed in this publication. Later editions of these publications may exist and should be used.

18.1 American National Standards Institute Documents

- ANSI T1.101-1994 *Synchronization Interface Standard*
- ANSI T1.102-1993 *Digital Hierarchy - Electrical Interfaces.*
- ANSI T1.105.09-1996 *Synchronous Optical Network (SONET): Network Element Timing and Synchronization.*
- ANSI T1.223-1997 *Information Interchange – Structure and Representation of Network Channel (NC) and Network Channel Interface (NCI) Codes for the North American Telecommunications System.*
- ANSI T1E1 Technical Report Number 28 *High-Bit-Rate Digital Subscriber Lined (HDSL), February 1994.*

18.2 Telcordia Documents

- GR-20-CORE *Generic Requirements for Optical Fiber and Fiber Optic Cable. Issue 1, September 1994.*
- GR-26-CORE *Generic Requirements For Controlled Environment Vaults (CEVs). Issue 1, December 1994*
- GR-27-CORE *Generic Requirements for Environmental Control Systems for Electronic Equipment Enclosures. Issue 1, November 1994.*
- GR-43-CORE *Generic Requirements for Telecommunications Huts. Issue 1, October 1996.*
- GR-63-CORE *Network Equipment - Building Systems (NEBS) Requirements: Physical Protection (A Module of LSSGR, FR-64 and of TSGR, FT-440). Issue 1, October 1995.*
- GR-253-CORE *Synchronous Optical Network (SONET) Transport Systems: Common Generic Criteria. Issue 2, December 1995.*
- GR-378-CORE *Timing Signal Generator (TSG) Requirements and Objectives. Issue 1, August 1995.*

- GR-342-CORE *High-Capacity Digital Special Access Service Transmission Parameter Limits and Interface Combinations.* December 1995.
- GR-436-CORE *Digital Network Synchronization Plan.* Issue 1, June 1994 and Revision 1, June 1996.
- GR-1089-CORE *Electromagnetic Compatibility and Electrical Safety - Generic Criteria for Network Telecommunications Equipment.* Issue 2, December 1997.
- GR-1244-CORE *Clocks for the Synchronized Network: Common Generic Criteria.* Issue 1, May 1 1995.
- SR-2275 *BOC Notes on the LEC Networks.* Issue 3, December 1997.
- SR-3580 *Network Equipment - Building Systems (NEBS) Criteria Levels.* Issue 1, November 1995.
- TR-EOP-000161 *Modular Distributing Frame System.* Issue 1, September 1986.
- TR-EOP-000163 *Modular Distributing Frame Framework.* Issue 1, March 1986.

18.3 QWEST Technical Publications

- PUB 77200 *QWEST DS1 Service and Synchronization Service.* Issue E, December 1998.
- PUB 77203 *QWEST Switched Access Service.* Issue C, May 2000.
- PUB 77204 *QWEST Digital Data Service, Product Description, Applications, and Interface Combinations.* Issue D, October 1998.
- PUB 77307 *Low Speed Data, Telegraph and Direct Current Services.* Issue A, April 2000.
- PUB 77310 *Private Line Voice Grade Analog Channels For Access Service.* Issue B, October 1998.
- PUB 77311 *Analog Channels for Non-Access Service.* Issue C, March 1991.
- PUB 77312 *QWEST Digital Data Service Technical Description.* Issue F, October 1998.
- PUB 77320 *QWEST Private Line Services.* Issue B, October 1989.

- PUB 77324 *QWEST DS3 Service. Issue C, April 1993.*
- PUB 77332 *QWEST Self-Healing Network Service (DS1, DS3, STS-1, OC-3 and OC-12). Issue L, January 2001.*
- PUB 77346 *Synchronous Service Transport. Issue G, January 2001.*
- PUB 77350 *Central Office Telecommunications Equipment Installation and Removal Guidelines. Issue K, June 2001.*
- PUB 77351 *Engineering Standards*
- *Module 1: General Equipment Requirements. Issue F, June 2001.*
- *Module 2: Standards Requirements. Issue C, January 1993.*
- *Module 3: General Output Requirements for Engineering Services Suppliers. Issue C, January 1993.*
- PUB 77355 *Grounding -- Central Office and Remote Equipment Environment. Issue C, August 1999.*
- PUB 77360 *Contractor's Specification Standards for Antenna and Waveguide Installation, Maintenance and Removal. Issue D, January 2000.*
- PUB 77372 *QWEST Frame Relay Service. Issue H, December 2000.*
- PUB 77375 *1.544 Mbit/s Channel Interfaces. Issue D, October 1995.*
- PUB 77378 *ATM Cell Relay Service. Issue D, March 1998.*
- PUB 77383 *Unbundled Dark Fiber. Issue F, June 2001.*
- PUB 77384 *QWEST Interconnection - Unbundled Loop. Issue I, June 2001.*
- PUB 77385 *Power Equipment and Engineering Standards. Issue F, January 2001.*
- PUB 77389 *Unbundled Dedicated Interoffice Transport. Issue E, June 2001.*
- PUB 77391 *Unbundled Switch Elements. Issue C, June 2001.*
- PUB 77392 *MegaBit Services. Issue H, May 2001.*
- PUB 77398 *Local Interconnect Service (LIS). Issue C, May 2001.*
- PUB 77403 *Enhanced Extended Loop (EEL). Issue B, June 2001.*

18.4 Other Publications

NECA Tariff FCC No. 4 *National Exchange Carrier Association, Inc.*

Tariff FCC No. 1

NFPA 70-1999 *National Electrical Code*®.

18.5 Ordering Information

All documents are subject to change and their citation in this document reflects the most current information available at the time of printing. Readers are advised to check status and availability of all documents.

Those who are not QWEST employees may order;

American National Standards Institute (ANSI) documents from:

American National Standards Institute
Attn: Customer Service
11 West 42nd Street
New York, NY 10036
Phone: (212) 642-4900
Fax: (212) 302-1286
Web: web.ansi.org/public/search.asp

ANSI has a catalog available that describes their publications.

Telcordia documents from:

Telcordia Customer Relations
8 Corporate Place, PYA 3A-184
Piscataway, NJ 08854-4156
Fax: (908) 336-2559
Phone: (800) 521-CORE (2673) (U.S. and Canada)
Phone: (908) 699-5800 (Others)
Web: www.telcordia.com

QWEST Technical Publications from:

<http://www.qwest.com/techpub>

Federal Communications Commission (FCC) documents may be obtained from:

Superintendent of Documents
Government Printing Office
Washington, D. C. 20402
Phone: 202 783-3238

National Electrical Code® information may be ordered from:

National Fire Protection Association
1 Battery March Park
PO Box 9101
Quincy, MA 02269-9904
Attn: Customer Service
Telephone: (800) 344-3555

Employees of QWEST Corporation. may order publications by submitting form RG 31-0033 to:

Central Distribution Center (CDC)
1005 17th St., S-30
Denver, CO 80202
Phone: (303) 896-9446
Fax: (303) 965-8652

Most QWEST publications are available to QWEST employees on the company network (E*MEDIA). Call 303-624-4796 for further information.

18.6 Trademarks

CLLI	Trademark of Telcordia
COMMON LANGUAGE	Registered Trademark of Telcordia
COSMIC	Registered Trademark of Lucent Technologies
National Electrical Code	Registered trademark of the National Fire Protection Association.
ST	Registered Trademark of Lucent Technologies, Inc.
QWEST®	Registered Trademark of QWEST Communications International Inc.

CONTENTS

Chapter and Section	Page
A. Combining Unbundled Network Elements	A-1
A.1 General.....	A-1
A.2 Example 1 -- Loop Only, Connection to Collocated Equipment.....	A-2
A.3 Example 2 -- Non-Loaded Loop Only For DS1 Transport	A-3
A.4 Example 3 -- Loop and DS1 Transport with Collocation	A-5
A.5 Example 4 -- Loop, Collocated Equipment and Finished Service.....	A-6
A.6 Example 5 -- Loop, Multiplexers and DS3 Transport	A-7
A.7 Example 6 -- Loop, Switch and DS1 Transport.....	A-8
A.8 Typical Ordering Process -- An Example	A-9
A.8.1 General.....	A-10
A.8.2 The Steps -- Single Collocation Example	A-10
A.8.3 The Steps -- Collocation in Both Wire Centers Example	A-13

Figures

A-1 Unbundled Loop to Collocated Equipment.....	A-2
A-2 Unbundled Loop for DS1 and Collocation.....	A-3
A-3 DS1 Transport, Regenerator and Loop	A-4
A-4 Unbundled Loop, Collocation and DS1 UDIT.....	A-5
A-5 Connections with Finished Services.....	A-6
A-6 Loop, Multiplex and DS3 Transport Example	A-8
A-7 Loop, Switch and DS1 Transport Example	A-9
A-8 Typical Ordering Process Example	A-12

A. Combining Unbundled Network Elements

A.1 General

Co-Carriers or Competitive Local Exchange Carriers (CLECs) will use combinations of various Unbundled Network Elements (UNEs) provided by QWEST along with their own facilities and equipment to provide service to their customers.

This appendix is provided to illustrate proper Network Channel (NC) and Network Channel Interface (NCI) code usage when ordering several UNEs with the intent to combine them into a service. Only the portion of these services provided by QWEST and limited connections provided by the CLEC are included in these illustrative examples. The CLEC is responsible for the end-to-end design of any combination of elements and/or their equipment to ensure that the resulting service meets their customer's needs.

There are a number of UNEs included in these examples. They include:

- Unbundled Loop as described in PUB 77384, *Interconnection - Unbundled Loop*.
- Unbundled Dedicated Interoffice Transport (UDIT) as described in PUB 77389, *Unbundled Dedicated Interoffice Transport*.
- Interconnection and Collocation as described in this publication.
- Unbundled Switch Ports are described in PUB 77391, *Unbundled Switch Elements*.

These publications should be consulted for further information about the respective UNEs.

Another document, PUB 77398, *Local Interconnect Service (LIS)*, describes a Finished Service (not a UNE) that may be encountered by a CLEC.

Certain tariffs, catalogs, contracts or regulatory orders may impact the issues related to these services that could modify the following examples. However, the examples should be applicable in most situations. These examples are not intended to provide specific ordering instructions for the UNEs.

The Network Interface (NI) in the QWEST wire center with these UNEs is a cross-connect frame called an Interconnector Distribution Frame (ICDF) frame or a Direct Connection - Point of Termination depending on the Interconnection arrangement. See Chapter 3 for further information. The remainder of this appendix assumes the ICDF Interconnection arrangement is in effect.

The UNEs and their Network Interfaces are described by NC and NCI codes. Some information about the codes used in these examples is included but the appropriate technical publication should be consulted for further information.

These examples omit some detail about the “Design-To” point. See Chapter 5 for further information on the design requirements related to the “Design-To” point.

A.2 Example 1 -- Loop Only, Connection to Collocated Equipment

Figure A-1 illustrates a situation where the CLEC is collocated in the QWEST wire center and purchases Unbundled Loop elements to reach their customer. It is assumed that there is collocated equipment.

The CLEC has purchased an Unbundled Loop with Loop-Start signaling. The 02QC3.OOD NCI code at the DS0/voice ICDF NI denotes that it is the open end of the Loop-Start channel. The NI at the End-User’s location is 02LS2 indicating the standard Loop-Start closed end interface. Further information about the Unbundled Loop may be found in PUB 77384.

A jumper is placed to connect the loop to previously placed cables connecting to their collocated Interconnector Designated Equipment (IDE). Further information about the cable and collocation may be found in Chapter 3.

The entrance facility is probably a Fiber Entrance Facility. This and other types of entrance facilities are described in Chapter 2.

In this example, the IDE would probably consist of multiplexers and fiber terminal equipment. This equipment is needed to multiplex the loop signal and place it on the fiber cable that would extend the loop to the CLEC’s location containing their switch.

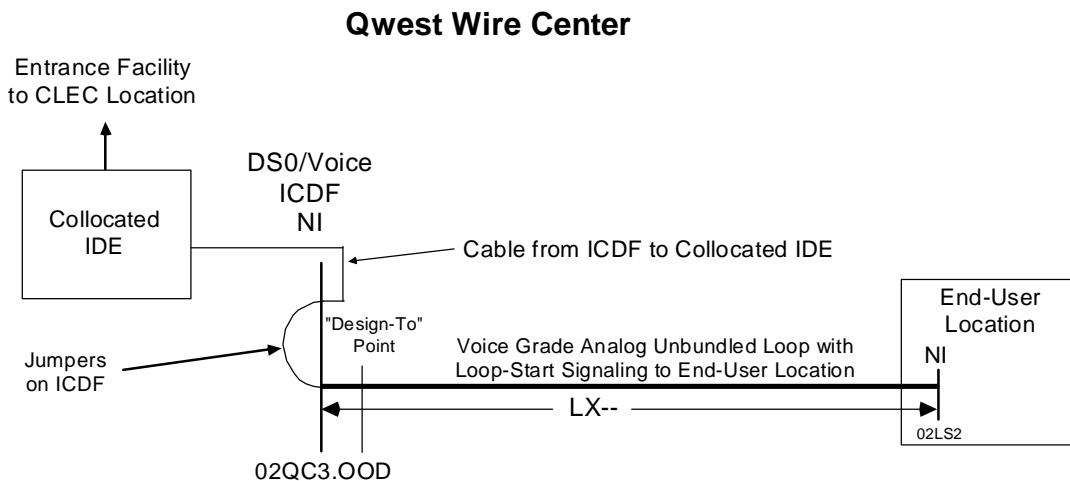

- Notes:**
 CLEC = Certified Local Exchange Carrier
 ICDF = InterConnection Distribution Frame
 IDE = Interconnector Designated Equipment
 NI = Network Interface

Figure A-1: Unbundled Loop to Collocated Equipment

A.3 Example 2 -- Non-Loaded Loop Only For DS1 Transport

This example (Figure A-2) is similar to Example 1 in that the CLEC purchases a Non-Loaded Unbundled Loop element from QWEST. The loop, however, is to be used to transport a DS1 to their customer's location using their High-bit-rate Digital Subscriber Line (HDSL) technology. It is assumed that there is collocated IDE.

The NC code LX-N for the Unbundled Loop element denotes a non-loaded Dedicated Facility (without equipment). The two NCI codes denote this facility as being used for HDSL. This designation is used to caution technicians to be aware of higher than normal voltages. Any performance parameters are as described in PUB 77384.

The HDSL equipment is placed by the CLEC in their IDE space and at the End-User's location on their respective sides of the NIs.

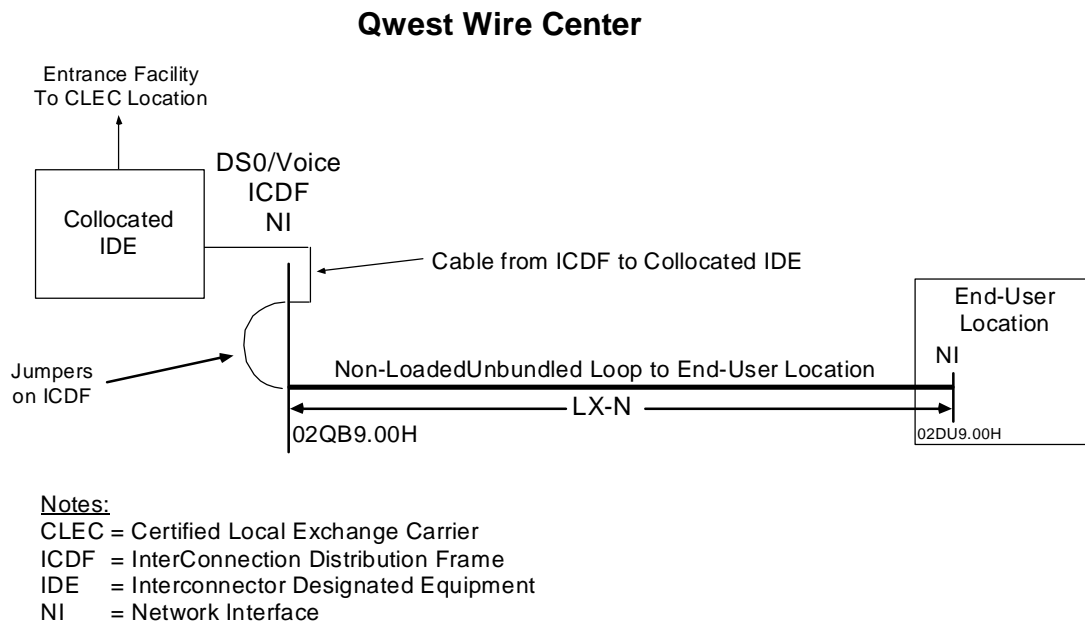

Figure A-2: Unbundled Loop for DS1 and Collocation

A.4 Example 3 -- Loop and DS1 Transport with Collocation

This example (Figure A-4) is similar to Example 1 except that the CLEC does not have an Entrance facility and cable to their location. Instead, the CLEC has purchased a DS1 UDIT to a remote wire center. Further details at the remote wire center are beyond the scope of this example.

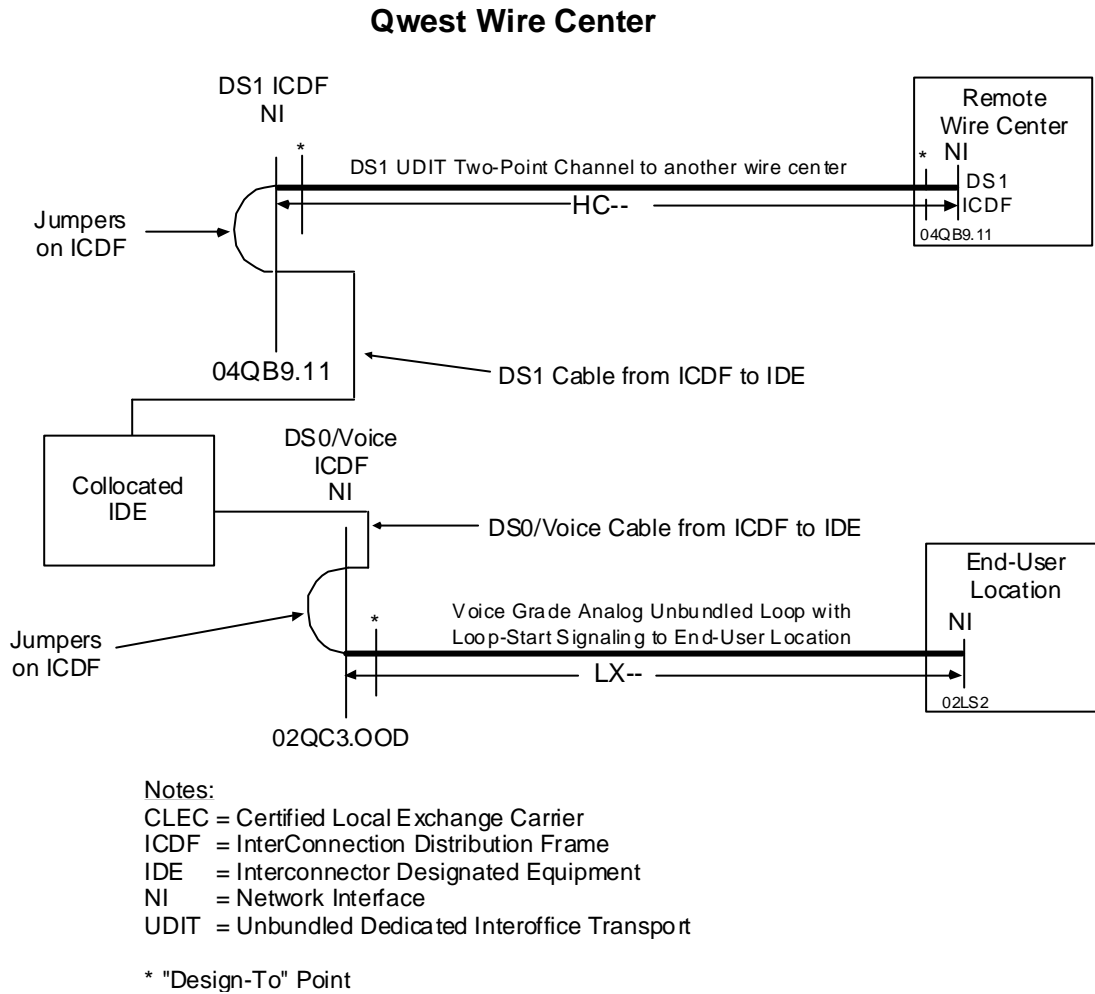

Figure A-3: Unbundled Loop, Collocation and DS1 UDIT

It is assumed that there is some IDE collocated in the wire center. The IDE would probably include DS1 multiplexers to multiplex the Analog Unbundled Loop up to the DS1 level.

A.5 Example 4 -- Loop, Collocated Equipment and Finished Service

This example, illustrated in Figure A-4, is similar to Example 1 (Section A.2, Figure A-1). The main difference is that the CLEC is using a DS3 Finished Service (PUB 77324) to enter the QWEST wire center instead of an entrance facility. The DS3 service goes from the CLEC-Point Of Termination (POT) out to the customer (i.e., the CLEC's customer) location. The NC code is HF--. The NCI code at the POT is 04DS6.44. The NCI code at the customer location in this example is not shown.

The POT is similar to an Interexchange Carrier-POT except that it is located in the wire center near the collocated IDE or near the ICDF. It is not located on the ICDF.

Since the DS3 is a Finished Service, QWEST has full design responsibility to the POT. The CLEC provides appropriate equipment and cable to connect the DS3 from the POT to their IDE.

In this example, the collocated IDE would include multiplexing equipment to channelize the DS3 for the voice channel that the CLEC connects to the Unbundled Analog Loop.

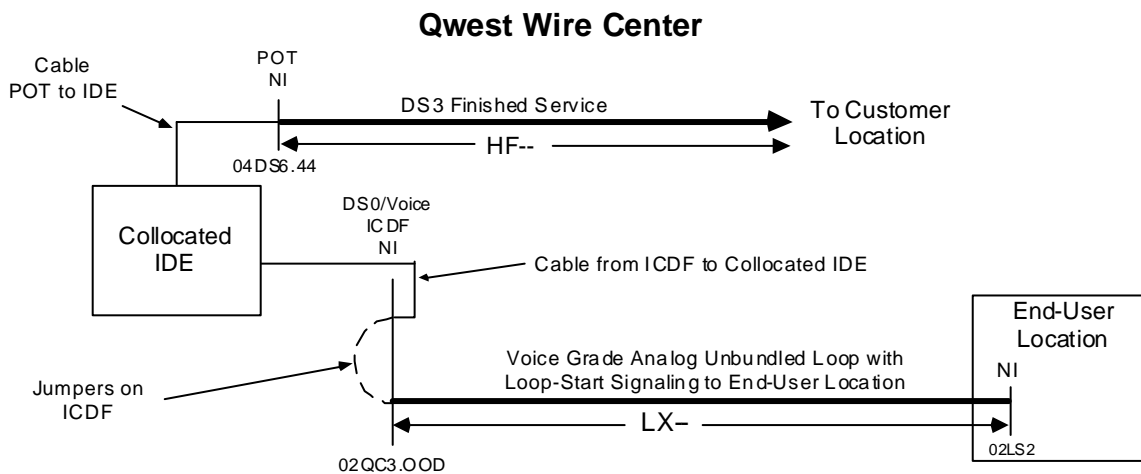

- Notes:**
- CLEC = Certified Local Exchange Carrier
 - ICDF = InterConnection Distribution Frame
 - IDE = Interconnector Designated Equipment
 - NI = Network Interface
 - POT = Point of Termination

Figure A-4: Connections With Finished Services

A.6 Example 5 -- Loop, Multiplexers and DS3 Transport

Figure A-6 illustrates a situation where the CLEC orders unbundled loops and DS3 level UDIT two-point channels to another QWEST wire center. UDIT multiplexers at both the DS1 and DS3 levels are ordered to multiplex the loops up to the DS3 level. It is assumed that there is also collocated equipment connected to the DS1 channels from the DS3 UDIT Multiplexer.

The unbundled loop is the same as in Example 1. The CLEC wants to connect (using jumper 6) the loop to channel 24 on the DS1 UDIT Multiplexer and issues instructions on channel unit selection, placement and options accordingly.

This low level channel (slot 24) with the NC code LC-- is described as a Voice Line. The NCI code is 02QC2.OOE (the closed end).

The DS1 UDIT Multiplexer is described by the NC code HCEG that denotes a DS1 with Voice and Digital Data Multiplexer. The DS1 is American National Standards Institute Extended Superframe with Bipolar Eight Zero Substitution (i.e., ANSI ESF with B8ZS).. Jumper 5, placed by QWEST, connects the regenerator to the high side of the multiplexer when needed. (Some regenerator arrangements may not be as pictured and may not require this jumper.)

The description of the DS3 UDIT Multiplexer is similar. The HF-1 NC code denotes a DS3 M-Framed channel with M2/3 Multiplex Format. The DS1 slots may be designated for B8ZS on a per-channel basis. Specifically, the low-level DS1 for channel 28 is designated using the HCE- NC code that indicates the ANSI ESF with B8ZS two-point channel. NCI codes for both DS1 and DS3 levels are as previously described.

Jumper 4 is placed to connect the DS1 UDIT Multiplexer (NCI code 04QB9.11) to channel 28 of the DS3 UDIT multiplexer (NCI code 04QB9.11).

Jumper 3 connects some DS1 IDE to Channel 1 of the DS3 UDIT Multiplexer. The IDE is used for some unspecified purpose.

Jumper 1 is placed to connect the DS3 UDIT Multiplexer with regenerator to the DS3 Two-Point UDIT channel. The NCI codes 04QB6.33 and 04QB6.33 apply to the DS3 multiplexer and DS3 two-point respectively.

Jumper 2 was place by QWEST to connect the high side of the DS3 multiplexer to the regenerator.

Connections in the remote wire center are not shown.

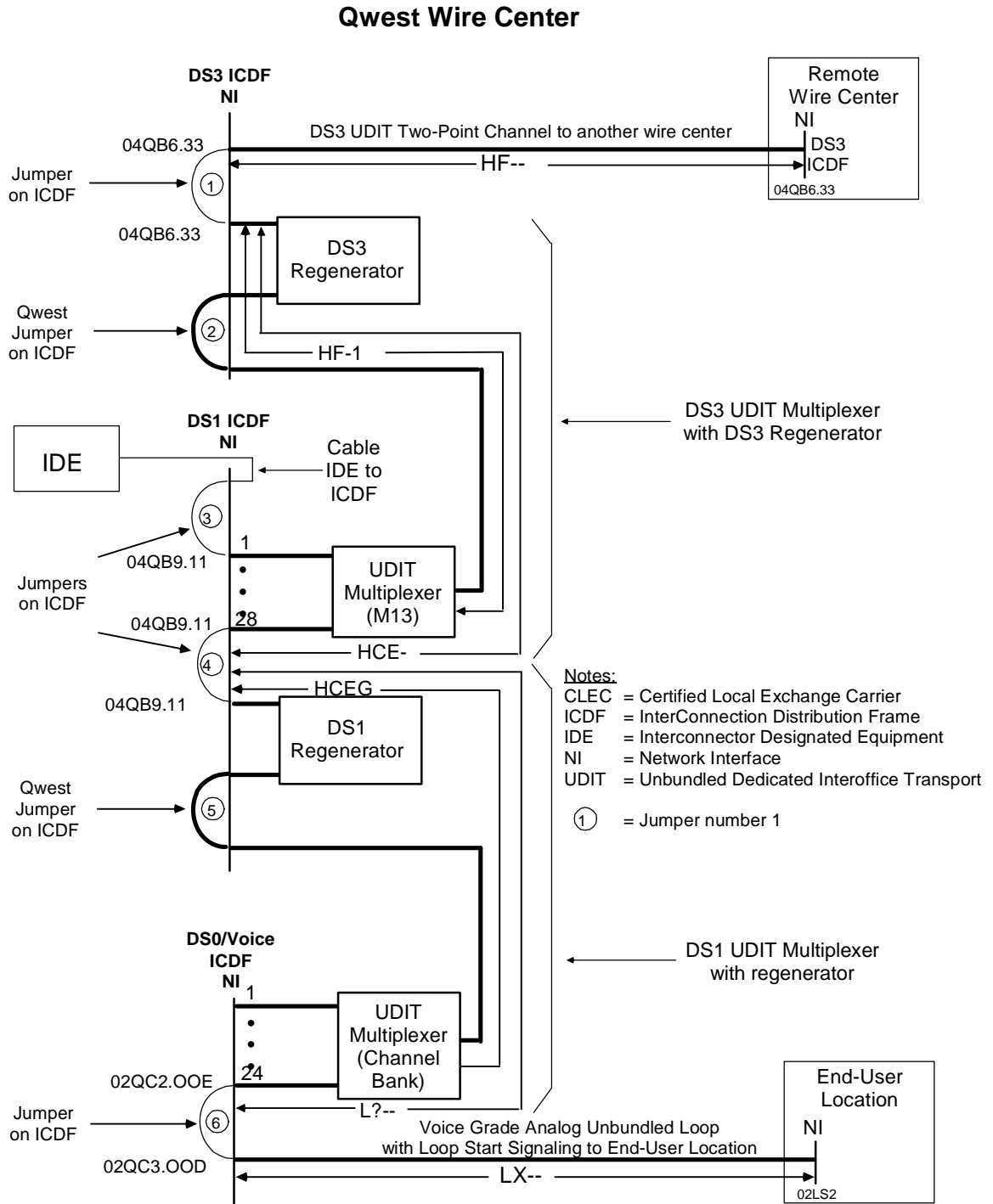
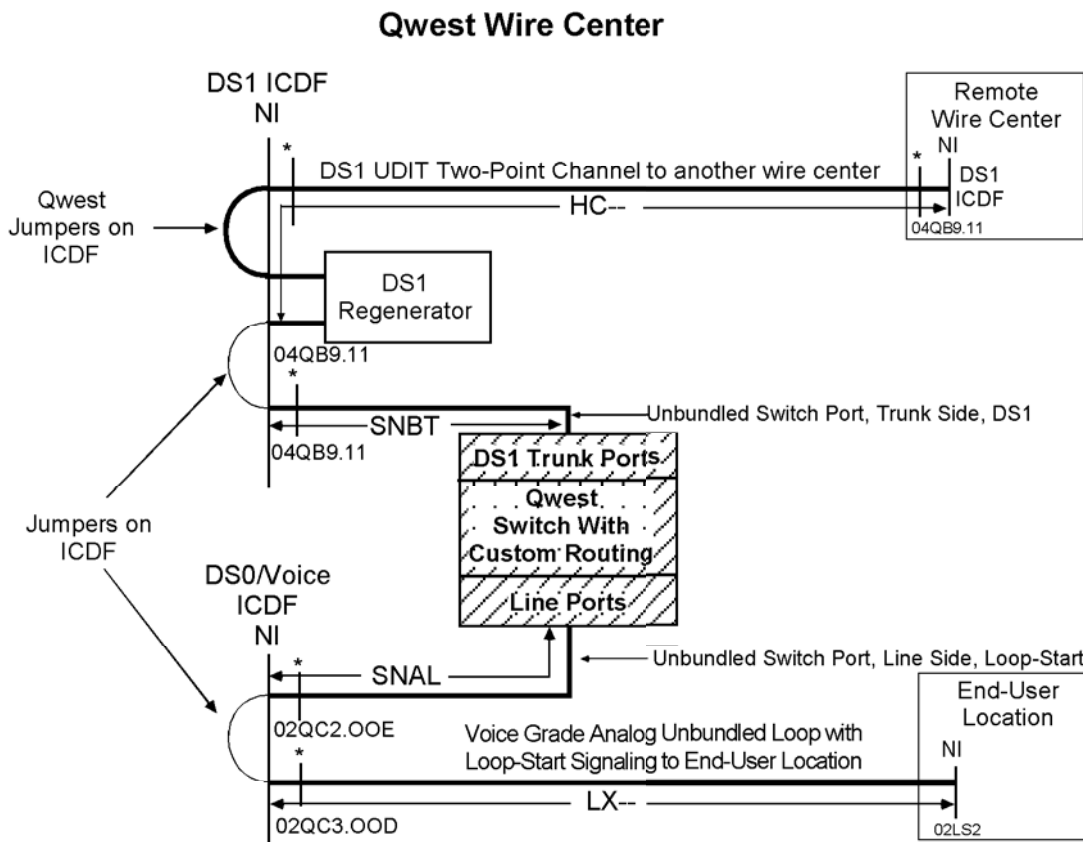

Figure A-5: Loop, Multiplex and DS3 Transport Example

A.7 Example 6 -- Loop, Switch and DS1 Transport

This example illustrates the situation where a CLEC wants to purchase Unbundled Loops and Unbundled Line-side Switch Ports from QWEST. The CLEC also needs to purchase Unbundled DS1 Trunk Ports and DS1 UDIT two-point channel elements to the remote wire center. The trunk port and UDIT requirement is to enable the line-side switch ports to originate calls outside the switch. Similar trunks and UDIT channels are required to other central offices in the same free-calling area but are not included in this example. Custom routing would also be required. It is assumed that there is no collocated equipment and that DS1 regenerators are required on the DS1 UDIT in both wire centers. Figure A-6 illustrates the arrangement. Further details at the remote wire center are beyond the scope of this example.



Notes:
 CLEC = Certified Local Exchange Carrier
 ICDF = InterConnection Distribution Frame
 NI = Network Interface
 UDIT = Unbundled Dedicated Interoffice Transport

* "Design-To" Point

Figure A-6: Loop, Switch and DS1 Transport Example

The two-point UDIT DS1 channel between this wire center and the remote wire center is defined by the NC code HC--. Chapter 5 of PUB 77389 defines this DS1 as having Superframe (SF) and Alternate Mark Inversion (AMI). The matching NCI codes, 04QB9.11, designate that the NIs are Manual Cross-Connect terminations with no subrating capability and that the connections are for DS1-to-DS1 cross-connects. The UDIT channel starts at the DS1 ICDF, goes through the DS1 Regenerator, back to the ICDF, and on to the remote wire center. The channel continues in the remote wire center in the reverse manner. The details are not shown in the remote wire center.

The Unbundled DS1 Switch Port is designated by the NC code SNBT. This code denotes the port as a Switched Access Port Termination using 4-wire local transmission parameters and a trunk termination. The 04QB9.11 NCI code applies at the NI. Further information about this port (along with Custom Routing and the line-side port) may be found in PUB 77391.

The dashed lines indicate a CLEC-provided jumper connecting the UDIT DS1 transport UNE to the DS1 Unbundled DS1 Switch trunk port. It is assumed that further connections will be required at the remote office. The result of this combination of QWEST-provided UNEs and CLEC-provided elements and equipment would be an interoffice trunk group(s) of up to 24 trunks assuming the CLEC ordered multiple trunks.

The situation on the other side of the switch is similar. The NC code SNAL describes an Unbundled Switch Port described as Switched Access Port Termination with 2-wire local transmission parameters with a line termination. The NCI code 02QC3.OOE denotes the NI as a Manual Cross-Connect DS0/Voice termination with the closed end of Loop-Start signaling.

The CLEC has also purchased an Unbundled Loop with Loop-Start signaling. The 02QC3.OOD code is similar to the 02QC3.OOE except that it is the open end. The NI at the End-User's location is 02LS2 indicating the standard Loop-Start closed end interface. Further information about the Unbundled Loop may be found in PUB 77384.

The figure shows the CLEC connecting these two UNEs together to form a standard Plain Old Telephone Service (POTS) line out to their customer.

A.8 Typical Ordering Process -- An Example

A.8.1 General

The process or procedure used to implement a service using combinations of UNEs obtained from QWEST will vary depending on specific situations and normal CLEC processes. This section is intended, by means of an example (with two variations), to illustrate one possible scenario that could be used to implement service to a CLEC customer using UNEs. More detailed information on the specific processes is available during the normal ordering processes.

This example assumes that a CLEC is collocated in a QWEST wire center with a fiber entrance facility connected to transport equipment or IDE. Assume that the CLEC has a small number of customers located in a nearby wire center area wanting DS1 service, but the quantities required are not enough to justify collocating IDE in the nearby wire center.

The solution is to purchase a DS3 two-point UDIT channel between the wire centers, a DS3 UDIT multiplexer in the distant wire center, and DS1 Unbundled Loops as required to meet the demand. The CLEC would connect the DS3 two-point UDIT channel to their collocated IDE at the DS3 level in the collocation wire center.

Since most of the activity takes place in the nearby wire center, designate the wire center containing the collocated IDE as the "Collocation Wire Center". Figure A-8 illustrates the layout of the arrangement similar to the other examples in this appendix. The entrance facility and IDE are not shown in the collocation wire center. The figure illustrates a DS1 Unbundled Loop using Alternate Mark Inversion (AMI) line code and Superframe (SF) format. This arrangement would allow the CLEC to provide a standard DS1 service to their customer

This example also shows a contrasting method of delivering the DS1 services by placing IDE in both wire centers. In this variation, the DS1 line code and frame format are ANSI Extended Superframe (ANSI ESF) with B8ZS line coding. Assume the DS3 multiplexing function is provided by the IDE in the nearby wire center. This contrasting example yields the same results, but illustrates the use of regenerators.

A.8.2 The Steps -- Single Collocation Example

The following steps could be followed to provide service with no IDE in the wire center. The circled numbers in Figure A-8 indicate the step numbers. Similar steps will be required at the collocation wire center where the CLEC is collocated.

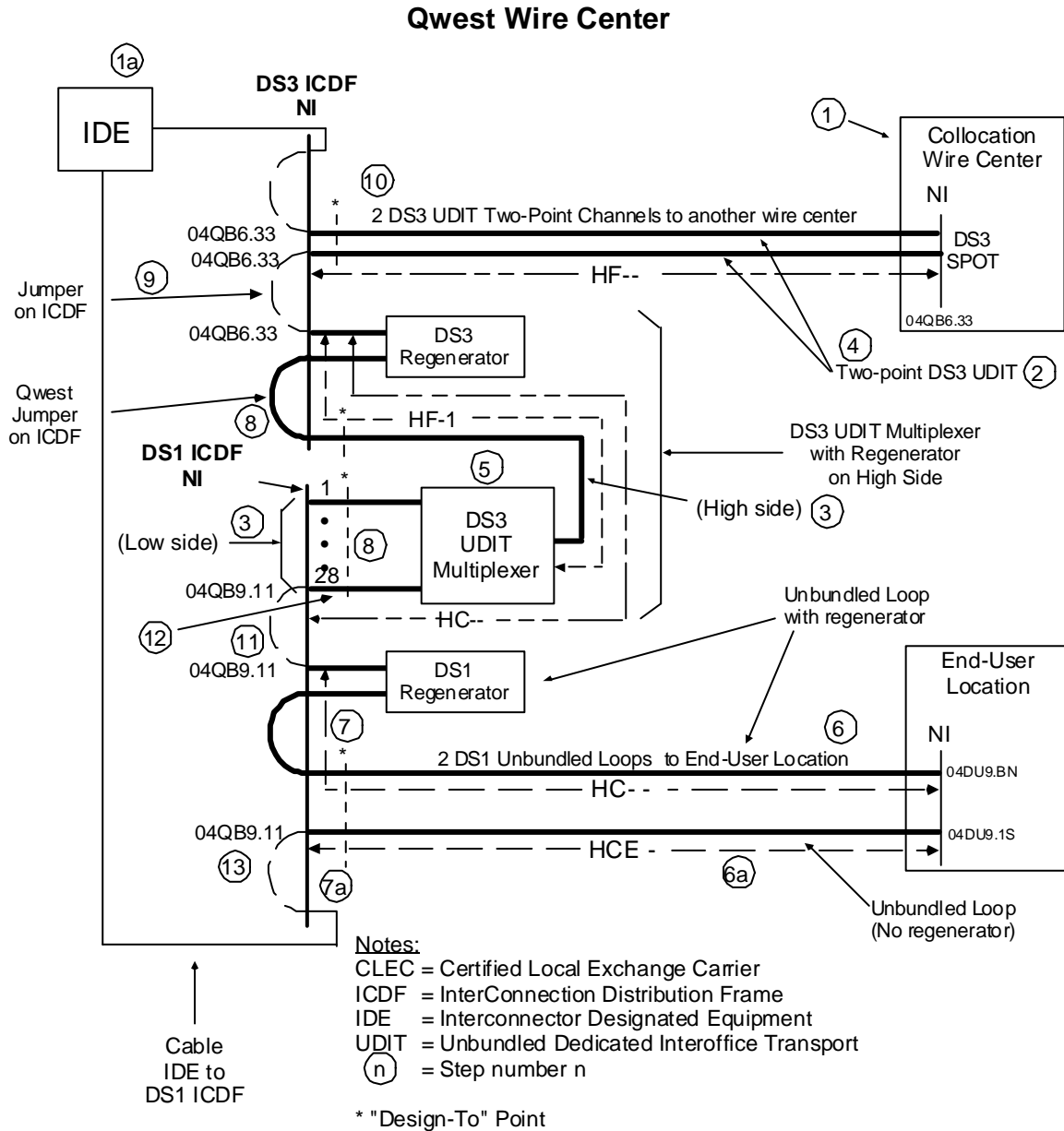

Figure A-7: Typical Ordering Process Example

1. Order and install any IDE in the collocation wire center.
2. Order the UDIT two-point DS3. The NC code is HF-- and the NCI codes at both ends are 04QB6.33. Order cooperative testing if desired for step 10. Make sure to request a Design Layout Report (DLR) to obtain characteristics and termination information needed by the CLEC to make their jumper connections on the DS3 ICDF.

3. Order the DS3 UDIT multiplexer on the high side and all 28 low side DS1 channels. Request DLRs for all 29 orders. Connecting Facility Assignments will specify the multiplexer and identify the channel.

Order cooperative testing if desired for step 10.

The 28 low side DS1 channels are ordered with the NC code HC-- (AMI and SF). Thus, the 28 NCI codes on the DS1 ICDF will all be 04QB9.11. The 28 NCI codes at the DS3 ICDF at the other end of the DS1s will be the same 04QB6.33 NCI code used with the DS3 HF-1 channel.

4. Receive the Firm Order Confirmation (FOC) for the DS3 UDIT from QWEST with the assigned carrier system identification in the form of a Common Language[®] Facility Identification (CLFI[™]) code.
5. Receive information via DLRs about DS3 channels from the multiplexer (high side) including characteristics and terminations on DS3 ICDF.

Receive information via DLRs about the 28 DS1 channels from the multiplexer (low side) including characteristics and terminations on DS1 ICDF.

6. Order the DS1 Unbundled Loop element and request DLR. The NC code is HC--. The NCI code is 04QB9.11 at the DS1 ICDF and 04DU9.BN at the End-User location. The DLR will provide information needed by the CLEC to make their jumper connections on the DS1 ICDF.
7. Receive information (via a DLR) about Unbundled DS1 Loop characteristics and termination on ICDF.

8. QWEST will install DS3 two-point UDIT and DS3 multiplexer UNEs including 28 sets of jumpers on the DSX-1 "Design-To" frame and one set of jumpers on the DSX-3 frame. The jumper connecting the DS3 regenerator to the multiplexer (high side) will be placed. Loop backs will be placed on the 28 DSX-1 frame cross-connects to prevent office alarms until the CLEC completes connections and places a signal on the channels. See Chapter 4 of PUB 77389 for further information.
9. Jumpers are placed on DS3 ICDF to connect UDIT two-point DS3 transport channel to UDIT DS3 multiplexer (high side).
10. CLEC and QWEST can do cooperative testing to turn up DS3 system end-to-end.
11. Jumpers are placed on DS1 ICDF to connect Unbundled DS1 Loop with regenerator to low-level channel of UDIT multiplexer element.
12. CLEC may request cooperative testing with QWEST to turn up end-to-end DS1 channel. During cooperative testing, QWEST will remove the loop back from the DSX-1 placed in step 8.

If cooperative testing was not requested, the CLEC will call QWEST through the trouble report process to remove the loop back.

The CLEC will keep records of cross-connections and other information about their end-to-end service. The proper selection of NC and NCI codes will enable the CLEC engineers to achieve compatibility with their equipment for their end-to-end service.

The CLEC ordered the following UNEs in this example:

- DS3 UDIT two-point channel (with DLR) between two wire centers
- DS3 UDIT Multiplexer (high side, with DLR)
- Twenty-eight (28) Low side DS1 channels of the UDIT DS3 Multiplexer (with DLRs)
- DS1 Unbundled Loop (with DLR)

A.9.3 The Steps -- Collocation in Both Wire Centers Example

This variation of the example assumes that the CLEC chooses to place IDE in both wire centers. The CLEC will order only the DS3 UDIT two-point UDIT channel between the wire centers and the DS1 Unbundled Loop. The additional IDE will provide the DS3 multiplexer function.

The step numbers in the following scenario are reused from the previous variation and appear in Figure A-8. Steps have been added or deleted as required.

1. Order and install any IDE in the collocation wire center.
 - 1a. Order and install the IDE in the other wire center.
2. Order the UDIT two-point DS3. NC code is HF-- and the NCI codes at both ends are 04QB6.33. Order cooperative testing if desired for step 10. Make sure to request a Design Layout Report (DLR) to obtain characteristics and termination information.
4. Receive the Firm Order Confirmation (FOC) for the DS3 UDIT from QWEST with the assigned carrier system identification in the form of a Common Language[®] Facility Identification (CLFI[™]) code.
 - 6a. Order the Unbundled DS1 Loop element and a DLR. The NC code is HCE-. The NCI code is 04QB9.11 at the DS1 ICDF and 04DU9.1S at the End-User location.
 - 7a. Receive information (via a DLR) about Unbundled DS1 Loop characteristics and termination on ICDF.
8. QWEST will install DS3 two-point UDIT including one set of jumpers on the DSX-3 "Design-To" frame.
 - 9a. Jumpers are placed on DS3 ICDF to connect UDIT two-point DS3 transport channel to their IDE.
10. CLEC and QWEST can do cooperative testing to turn up DS3 system end-to-end.
13. Jumpers are placed on DS1 ICDF to connect Unbundled DS1 Loop to their DS1 IDE.

CLEC may request cooperative testing with QWEST to turn up end-to-end DS1 channel.

The CLEC will keep records of cross-connections and other information about their end-to-end service. The proper selection of NC and NCI codes will enable the CLEC engineers to achieve compatibility with their equipment for their end-to-end service.

The CLEC ordered the following UNEs in this example:

- DS3 UDIT two-point channel (with DLR)
- DS1 Unbundled Loop (with DLR)

CONTENTS

Chapter and Section	Page
B. Unbundled Network Elements (UNEs) and Related Topics.....	B-1
B.1 Unbundled Loop UNE.....	B-1
B.1.1 Network Interface Description.....	B-1
B.1.2 Unbundled Analog Loop.....	B-2
B.1.3 Unbundled Digital Non-Loaded Loops.....	B-2
B.1.4 DS1 Capable Loop.....	B-3
B.1.5 Applicable Network Channel & Channel Interface Codes.....	B-3
B.1.6 Design Responsibilities	B-6
B.2 Unbundled Dedicated Interoffice Transport (UDIT) Element	B-6
B.2.1 UNE Description.....	B-6
B.2.2 DS3 UDIT Elements.....	B-6
B.2.3 DS1 UDIT Elements	B-9
B.2.4 DS0 UDIT	B-11
B.2.5 Unbundled Customer Controlled Reconfiguration Element	B-11
B.2.6 OC-n UDIT Elements.....	B-12
B.2.7 Extended-UDIT Elements.....	B-13
B.2.8 Future UDIT Enhancements.....	B-13
B.3 Unbundled Dark Fiber	B-13
B.4 Unbundled Switch Elements.....	B-15
B.4.1 Unbundled Analog Line Port Service	B-15
B.4.2 Unbundled DS1 Trunk Port Service.....	B-15
B.4.3 Unbundled Direct Inward Dial Trunk Port Service.....	B-15
B.4.4 Unbundled Basic Rate ISDN Port Service	B-16
B.4.5 Unbundled Primary Rate ISDN Port Service.....	B-16
B.5 Other Unbundled Network Elements.....	B-16

CONTENTS (Continued)

Figures	Page
B-1 Typical 2-Wire Unbundled Loop UNE Configuration.....	B-3
B-2 Typical DS3 Two-Point UDIT UNE.....	B-8
B-3 Typical DS3 UDIT Multiplexer UNE	B-9
B-4 Typical DS1 Two-Point UDIT UNE.....	B-10
B-5 Typical DS1 UDIT Multiplexer UNE	B-11
B-6 Typical OC-n Two-Point UDIT Element	B-12

Tables

B-1 Unbundled Loop UNE NC and NCI Codes.....	B-4
B-2 Applicable DS3 Network Channel Interface Codes -- DS3 UDIT.....	B-7
B-3 Applicable DS3 Network Channel Codes -- DS3 UDIT	B-7
B-4 Applicable DS1 NC and NCI Codes -- DS1 UDIT.....	B-10
B-5 Two-Point OC-n UDIT Network Channel Codes	B-12
B-6 OC-n UDIT Network Channel Interface Codes.....	B-13
B-7 Available Dark Fiber NCI Codes	B-14
B-8 Dark Fiber NC and NCI Code Combinations.....	B-14

B. Unbundled Network Elements (UNEs) and Related Topics

There are a number of UNEs that a Competitive Local Exchange Carrier (CLEC) may connect together, along with any of their own facilities and equipment, to create a service for their customers. This chapter provides an overview of several Unbundled Network Elements (UNEs) provided by QWEST. The reader should consult the identified technical publications for further information. Appendix A of this document illustrates proper Network Channel (NC) and Network Channel Interface (NCI) code usage when combining these UNEs.

In case of conflicting information about the UNE, the specific UNE Technical Publication should be used rather than this appendix.

This appendix assumes that the Network Interface (NI) with the CLEC is an Interconnection Distribution Frame (ICDF) frame. Other Interconnection arrangements, such as the Direct Connection - Point of Termination arrangement, may also apply. See Chapter 3 for further information. Information in this appendix about the ICDF would apply to the other arrangements with minor modifications.

B.1 Unbundled Loop UNE

One UNE is the Unbundled Loop UNE. The Unbundled Loop UNE, formerly known as LIS-Link or Interconnection-Unbundled Loop, provides unbundled analog and digital channels (loops). The Unbundled Loop extends from a Network Interface (NI) at a QWEST Central Office (wire center) to an End-User's premises interface located within the serving area of that Central Office. This UNE provides:

- A voice frequency transmission path of approximately 3 kHz of usable bandwidth between the End-User's premises NI and the QWEST NI in the wire center.
- Non-Loaded, 2- and 4-Wire metallic facilities from the QWEST wire center NI to the End-User's premises NI.
- A Basic Rate ISDN, Digital Subscriber Line transmission path between the End-User's premises NI and the QWEST wire center NI.
- A DS1 Capable Loop that provides a 1.544 Mbit/s transmission path between the End-User's premises NI and the QWEST wire center NI.

Further information may be found in PUB 77384, *QWEST Interconnection -Unbundled Loop*.

B.1.1 Network Interface Description

The NI in the wire center is the ICDF. The ICDF frame is described in Chapter 3.

B.1.2 Unbundled Analog Loop

An Unbundled Analog Loop is a voice frequency transmission path that runs from the ICDF to the End-User NI located at the their designated premises.

Characteristics associated with an Unbundled Analog Loop are in accord with the following interfaces:

- 2-Wire analog interfaces supporting loop-start signaling with a transmission path designed to carry analog voice frequency signals nominally between 300 and 3000 Hz.
- 2-Wire analog interfaces supporting ground-start signaling with a transmission path designed to carry analog voice frequency signals nominally between 300 and 3000 Hz.
- 2-Wire analog interfaces supporting reverse battery signaling with a transmission path designed to carry analog voice frequency signals nominally between 300 and 3000 Hz.
- 2-Wire analog interfaces with no signaling functions provided by QWEST and a transmission path designed to carry analog voice frequency signals nominally between 300 and 3000 Hz.
- 4-Wire analog interfaces with no signaling functions provided by QWEST. Its associated transmission channel will carry analog voice frequency signals, nominally between 300 and 3000 Hz, using separate transmit and receive paths.

QWEST may provide Unbundled Loop UNEs using a variety of transmission technologies including, but not limited to, metallic wire, metallic wire-based digital loop carrier and fiber optic digital loop carrier systems. Such technologies can be used singularly or in tandem to provide Unbundled Loop UNEs. Direct current continuity is not inherent in this UNE.

B.1.3 Unbundled Digital Non-Loaded Loops

An Unbundled Non-Loaded Loop is a transmission path that runs from a QWEST ICDF to the End-User NI located at the their designated premises.

This unbundled offering includes either a 2- or 4-wire metallic, wire cable pair(s) with no loading coils. Digital transport systems require facilities of this type to function.

Characteristics associated with an Unbundled Non-Loaded Loop are in accord with the following End-User NIs:

- 2-Wire digital interface supporting Asymmetric Digital Subscriber Line (ADSL).

- 4-Wire digital interfaces supporting digital data services or High-Bit-Rate Digital Subscriber Line (HDSL).
- 2-Wire digital interfaces supporting basic rate Integrated Services Digital Network (ISDN) with 2B1Q line code, nominally 160 kbit/s, with a qualified transmission path to an End-User's premises.

B.1.4 DS1 Capable Loop

An Unbundled DS1 Capable Loop is a digital transmission path that runs from a DS1 ICDF frame in the QWEST wire center to the End-User NI located at the End-User's designated premises. The DS1 Capable Loop transports bi-directional DS1 signals with a nominal transmission rate of 1.544 Mbit/s.

Characteristics associated with an Unbundled Digital Loop as defined above are in accord with the following interfaces:

- 4-Wire digital interfaces supporting Bipolar Alternate Mark Inversion (AMI) or Binary, Eight Zero Substitution (B8ZS) line codes, nominally 1.544 Mbit/s, over a qualified transmission path to an End-User's premises.

The "Design-To" point for the DS1 Capable Loop is a DSX-1 cross-connect frame. This frame could be identified by an NCI code of the form *04DS9.xxx* if it were a NI where the x's indicate the appropriate line code and frame format. See Chapter 8 for further information.

B.1.5 Applicable Network Channel & Channel Interface Codes

Table B-1 lists the applicable Network Channel (NC) and Network Channel Interface (NCI) Codes used with the Unbundled Loop UNE. Each line of the table lists compatible NCI codes. See PUB 77384 for further information.

Figure B-1 illustrates a typical 2-wire Loop Start configuration.

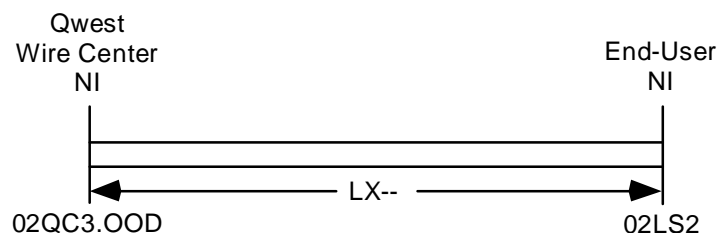

Figure B-1: Typical 2-Wire Unbundled Loop UNE Configuration

Table B-1: Unbundled Loop UNE NC and NCI Codes

Loop NC Code*	End-User NI NCI Code†	QWEST Central Office **	
		NCI Code **	Description
Analog Loop			
LX--	02LS2	02QC3.OOD	Loop Start Loop Signaling, open end
	02GS2	02QC3.OOB	Ground Start Loop Signaling, open end
	02RV2.O	02QC3.RVT	Reverse Battery: Loop Closure provided by the End-User
	02RV2.T	02QC3.RVO	Reverse Battery: Reverse Battery provided by the End-User
	02NO2	02QC2.OOF	Transmission Only, No Signaling
	04NO2	04QC2.OOF	Transmission Only, No Signaling
Non-Loaded Loop -- Digital Data			
LX-N	04DU5.	04QB5.00	2.4 kbit/s, not DS0A Level signal
	04DU5.	04QB5.00	2.4 kbit/s, with secondary channel, not DS0A Level signal
	04DU5.	04QB5.00	4.8 kbit/s, not DS0A Level signal
	04DU5.	04QB5.00	4.8 kbit/s, with secondary channel, not DS0A Level signal
	04DU5.	04QB5.00	9.6 kbit/s, not DS0A Level signal
	04DU5.	04QB5.00	9.6 kbit/s, with secondary channel, not DS0A Level signal
	04DU5.	04QB5.00	19.2 kbit/s, not DS0A Level signal
	04DU5.	04QB5.00	19.2 kbit/s, with secondary channel, not DS0A Level signal
	04DU5.	04QB5.00	56.0 kbit/s, not DS0A Level signal
	04DU5.	04QB5.00	56.0 kbit/s, with secondary channel, not DS0A Level signal
	04DU5.	04QB5.00	64.0 kbit/s, not DS0A Level signal
Non-Loaded Loop -- Basic Rate ISDN			
LX-N	02IS5	02QC5.OOS	Digital Subscriber Line with 2B1Q Signaling Format
Non-Loaded Loop -- High-Bit-Rate Digital Subscriber Line			
LX-N	02DU9.00H	02QB9.00H	HDSL Compatible Loop, Metallic Facility ONLY per ANSI T1E1 Technical Report Number 28
	04DU9.00H	04QB9.00H	HDSL Compatible Loop, Metallic Facility ONLY per ANSI T1E1 Technical Report Number 28

* LX is defined as *Dedicated facility (without equipment)*.

AD-- is defined as *Basic Rate ISDN, nominally 160 kbit/s (144 kbit/s payload)*.

† Information about these NCI codes may be found in the appropriate technical publication.

** The "QC" NCI code is defined as *Central Office Manual Cross-Connect DS0/Voice*.

Table B-1: Unbundled Loop UNE NC and NCI Codes (Continued)

Loop NC Code*	End-User NI NCI Code†	QWEST Central Office **	
		NCI Code **	Description
Asymmetric Digital Subscriber Line (ADSL) Qualified			
LXR-	02DU5.00A	02QB5.00A	Revised Resistance Design (RRD) Loop that is ADSL qualified with ANSI T1.413 DMT Signaling Format
LXR-	02DU5.01A	02QB5.01A	RRD Loop that is ADSL qualified with ANSI T1.413 DMT Signaling Format and one POTS Channel
LXR-	02DU5.00C	02QB5.00C	RRD Loop that is ADSL qualified with CAP Signaling Format
LXR-	02DU5.01C	02QB5.01C	RRD Loop that is ADSL qualified with CAP Signaling Format and one POTS Channel
DS1 Compatible Loop			
HC--	04DU9.BN	04QB9.11	SF Format per GR-342-CORE, AMI
HCD-	04DU9.1KN	04QB9.11	ANSI ESF, AMI
HCE-	04DU9.1SN	04QB9.11	ANSI ESF, B8ZS
HCF-	04DU9.CN	04QB9.11	Non-ANSI ESF, AMI,
HCG-	04DU9.SN	04QB9.11	Non -ANSI ESF, B8ZS
HCJ-	04DU9.AN	04QB9.11	Free Framing and B8ZS
HCZ-	04DU9.DN	04QB9.11	SF Format per GR-342-CORE, B8ZS

† Information about these NCI codes may be found in the appropriate technical publication.

** The "QC" NCI code is defined as *Central Office Manual Cross-Connect Termination DS0/Voice*.

The "QB" NCI code is defined as *Central Office Manual Cross-Connect Termination with no subrating capability, DS1-to-DS1. May or may not meet DS1 Signal Levels as specified by GR-342-CORE.*

B.1.6 Design Responsibilities

QWEST will provide the Interconnector information describing the unbundled loop. The Interconnector then has the responsibility to design their equipment and facilities and provide appropriate IDE.

B.2 Unbundled Dedicated Interoffice Transport (UDIT) Element

B.2.1 UNE Description

Unbundled Dedicated Interoffice Transport (UDIT) is a UNE available to a CLEC. There are three types of UNEs, the two-point channel, the multiplexer and a customer rearrangement capability.

UDIT provides a two-point transport channel between two QWEST wire centers, i.e., interoffice. An alternate arrangement exists where one of the two wire centers may belong to another LEC located outside of the QWEST exchange area. The transport channels are available at OC-12, OC-3, DS3, DS1 and DS0 levels.

UDIT is also available as a multiplexer at the DS1 and DS3 levels.

A variation called Extended-UDIT provides a two-point transport channel between the QWEST serving wire center and either a CLEC's wire center or an Interexchange Carrier's wire center. See Section B.2.7 for further information.

Further information about the UDIT and Extended-UDIT channels may be found in PUB 77389, *Unbundled Dedicated Interoffice Transport*.

B.2.2 DS3 UDIT Elements

UDIT at the DS3 level provides a two-point DS3 (44.736 Mbit/s) channel between two QWEST wire centers. The NI is the DS3 ICDF cross-connect bay or frame. A DS3-to-DS1 UDIT multiplexer UNE is also available.

Several options of signal format are available and are summarized in this section. Chapter 4 of PUB 77389 should be consulted for further information.

Table B-2 lists the applicable DS3 level NCI codes for the DS3 UDIT. C-Bit Parity is not available in all locations.

The "DS" Protocol Code denotes a Digital Hierarchy Interface and the options ("44", "44A" and "44I") indicate the descriptive information in the table.



The "QB" Protocol Code denotes a Central Office Manual Cross-Connect termination with no subrating capability and the options "33" denote a DS3-to-DS3 cross-connect (which may or may not meet DS3 templated signal levels).

The applicable NC codes are listed in Table B-3.

Table B-2: Applicable DS3 Network Channel Interface Codes -- DS3 UDIT

Description	NI (ICDF)	"Design-To" Point
DS3 M-framed with M2/3 Multiplexer format	04QB6.33	04DS6.44
DS3 M-framed with M2/3 Multiplexer format & C-Bit Parity	04QB6.33	04DS6.44I
DS3 M-framed (may have C-Bit Parity) -- Unchannelized	04QB6.33	04DS6.44A

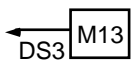
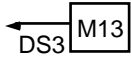
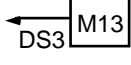
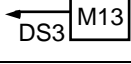
Table B-3 Applicable DS3 Network Channel Codes -- DS3 UDIT

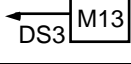
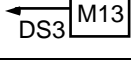
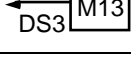
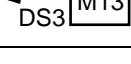
NC Code	Description	Options	Illustration
HF--	DS3, M-Framed, M2/3 Multiplex Format	None *	
HF-1		Central Office Multiplexing, Multiplexer can be optioned for one (1) DS1 Clear Channel at a time using B8ZS line code	
HF-4		Central Office Multiplexing, Multiplexer can be optioned for four (4) DS1 Clear Channels at a time using B8ZS line code	
HF-7		Central Office Multiplexing, Multiplexer can be optioned for seven (7) DS1 Clear Channels at a time using B8ZS line code	
HF-M		Central Office Multiplexing (DS1 Clear Channel Capability optioning capability not specified)	
HFC-	DS3, M-Framed, M2/3 Multiplex Format, C-Bit Parity	None *	
HFCM		Central Office Multiplexing (DS1 Clear Channel Capability optioning capability not specified)	
HFC1		Central Office Multiplexing, Multiplexer can be optioned for one (1) DS1 Clear Channel at a time using B8ZS line code	
HFC4		Central Office Multiplexing, Multiplexer can be optioned for four (4) DS1 Clear Channels at a time using B8ZS line code	
HFC7		Central Office Multiplexing, Multiplexer can be optioned for seven (7) DS1 Clear Channels at a time using B8ZS line code	

* M2/3 Format is optional.

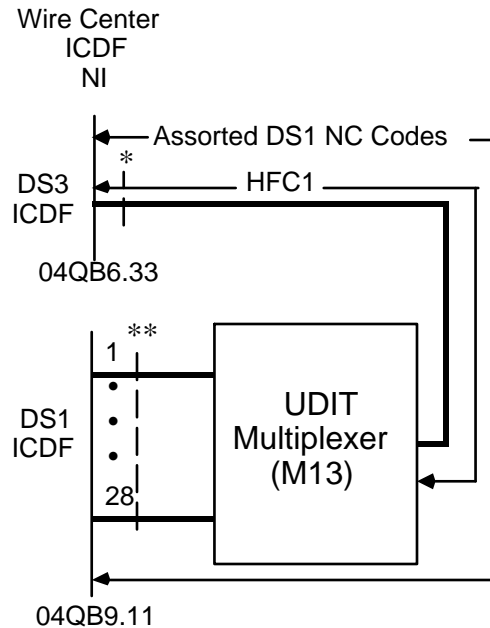

- ICDF = InterConnection Distribution Frame
- NI = Network Interface
- UDIT = Unbundled Dedicated Interoffice Transport
- * = "Design-To" Point (DSX-3). Would use NCI codes of 04DS6.44I if it were an NI.
- ** = "Design-To" Point (DSX-1). Would use various NCI codes if it were an NI.

Figure B-3: Typical DS3 UDIT Multiplexer UNE

B.2.3 DS1 UDIT Elements

Unbundled Dedicated Interoffice Transport (UDIT) at the DS1 level provides a two-point DS1 (1.544 Mbit/s) channel between two QWEST wire centers. The NI is the ICDF cross-connect bay or frame.

Table B-4 lists the applicable NC and NCI codes for the DS1 UDIT.

The "DS" Protocol Code denotes a Digital Hierarchy Interface and the options ("15", "1K", etc.) indicate the line code and frame format information in the table.

The "QB" Protocol Code denotes a Central Office Manual Cross-Connect termination with no subrating capability and the options "11" denote a DS1-to-DS1 cross-connect (which may or may not meet DS1 templated signal levels). The NC code needs to be consulted since the 04QB9.11 NCI code does not describe the frame format and line code.

Table B-4: Applicable DS1 NC and NCI Codes -- DS1 UDIT

Line Code and Frame Format	Network Channel Code	Network Interface (ICDF)		"Design-To" Point *
SF & AMI	HC--	04QB9.11		04DS9.15
ANSI ESF & AMI	HCD-	04QB9.11		04DS9.1K
ANSI ESF & B8ZS	HCE-	04QB9.11		04DS9.1S
Non-ANSI ESF & AMI	HCF-	04QB9.11		04DS9.15K
Non-ANSI ESF & B8ZS	HCG-	04QB9.11		04DS9.15S
Free Framing and B8ZS	HCJ-	04QB9.11		04DS9.15J
SF & B8ZS	HCZ-	04QB9.11		04DS9.15B

* See Chapter 5.

Figure B-4 illustrates a typical two-point DS1 UDIT channel between Wire Center A and Wire Center B. The NC codes, described in Table B-5, indicate that the DS1 channel is ANSI ESF and B8ZS. The asterisks (*) show the "Design-To" Points.

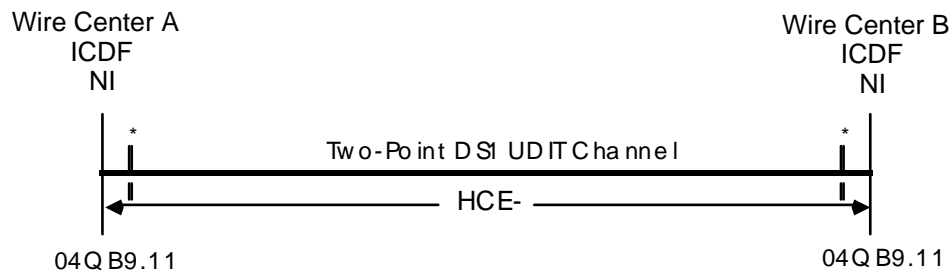

ICDF = InterConnection Distribution Frame
 NI = Network Interface
 UDIT = Unbundled Dedicated Interoffice Transport
 * = "Design-To" Point (DSX-1). Would use NCI code of 04DS9.1S if it were an NI.

Figure B-4: Typical DS1 Two-Point UDIT UNE

There is a DS1 Multiplexer UNE available. The DS1 Multiplexer UNE multiplexes 24 DS0 or Voice channels into a DS1. Figure B-5 illustrates a typical application.

There are various low level analog and digital channels available. See PUB 77389, Issue B or later, for further information.

The CLEC controls the DCS by means of a Customer Controller. The CLEC accesses the controller via a dial-up line or a QWEST attendant.

UCCRE is available only in selected wire centers and on selected DCSs in these wire centers. Expansion to additional wire centers or DCSs is done on an inquiry basis.

There are three types of UCCRE ports: DS1, DS3 and Virtual.

The CLEC has the responsibility to order and connect UCCRE ports, other UNEs, and their own equipment that are technically compatible.

See PUB 77389, Issue B or later, for further information.

B.2.6 OC-n UDIT Elements

UDIT two-point channels are also available at the OC-3, OC-12 and OC-48 levels. Chapter 8 of PUB 77389, Issue D or later should be consulted for further information. Figure B-6 illustrates a typical UNE illustrating proper NC and NCI codes. Tables B-5 and B-6 list the valid NC and NCI codes.

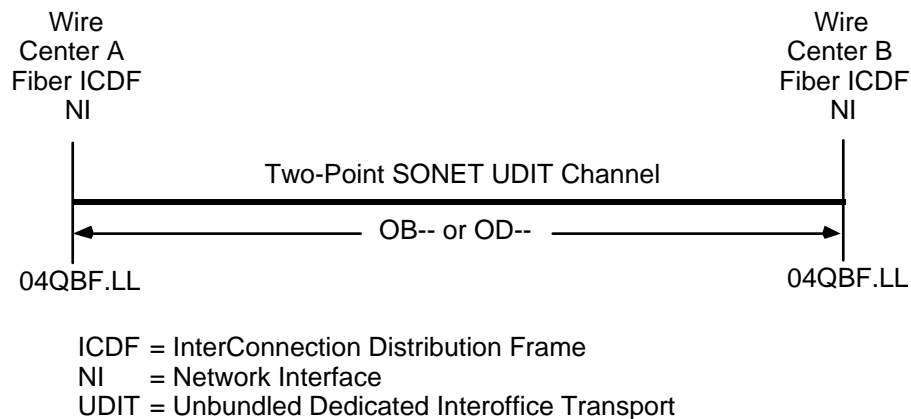

Figure B-6: Typical OC-n Two-Point UDIT Element

Table B-5: Two-Point OC-n UDIT Network Channel Codes

NC Code	Description
OB--	OC-3 SONET Point-to-Point (No Central Office Multiplexing)
OD--	OC-12 SONET Point-to-Point (No Central Office Multiplexing)
OF--	OC-48 SONET Point-to-Point (No Central Office Multiplexing)

Table B-6: OC-n UDIT Network Channel Interface Codes

NC Code	Description
04QBF.LL	Central Office Manual Cross-Connect Termination With No Subrating Capability, Fiber Cross-Connect or Fiber Distribution Bay

B.2.7 Extended-UDIT Elements

Extended-UDIT (E-UDIT) provides a two-point channel between either a CLEC Wire Center or an Interexchange Carrier Wire Center and the QWEST Serving Wire Center. The E-UDIT channel is limited to a single interoffice span.

The actual NI is at the other carrier's wire center or at some point between the other wire center and the QWEST wire center.

No QWEST equipment will be placed in the other carrier's wire center. Joint design and engineering will be required between the other carrier and QWEST.

E-UDIT is available at the DS1, DS3, OC-3 and OC-12 levels.

The establishment of an E-UDIT channel requires that a base facility be in place. All four levels could be transported on a fiber cable. The DS1 E-UDIT could be transported on metallic cable. The base facility will consist of cable, the structure to support the cable, and appropriate transmission equipment to provide the capacity to transport the E-UDIT UNE(s).

PUB 77389, Issue C or later should be consulted for additional information.

B.2.8 Future UDIT Enhancements

Information about future UDIT enhancements will be added when they become available. See PUB 77389 for the latest information.

B.3 Unbundled Dark Fiber

Unbundled Dark Fiber is a pair of optical fibers on which no electronic terminal equipment is provided by QWEST. The fibers will be terminated on Fiber Distribution Panels (FDPs) located in QWEST wire centers. The fiber pairs will be wire center-to-wire center (interoffice) spans or wire center-to-remote FDP (loop) spans.

The customer will provide all optical and electronic equipment required to make the fiber pairs usable. This may include terminating equipment, protection switching equipment, multiplexers, alarm and performance monitoring equipment and other similar equipment.

Further information about Unbundled Dark Fiber may be found in the QWEST Technical Publication 77383.

Table B-7 lists the available NCI codes. Table B-8 lists the valid NC and NCI code combinations.

Table B-7: Available Dark Fiber NCI Codes

Protocol		Definition
Code 3 4	Option 7 8 9	
FC	X	Fiber Optic Interface Dark Fiber
QB	LLX	Central Office Manual Cross-Connect Termination With No Subrating Capability Fiber Cross-Connect or Fiber Distribution Bay or Panel — Dark Fiber

Table B-8: Dark Fiber NC and NCI Code Combinations

NC / NCI Combinations			
NC = LX-- Dedicated Facility (No Equipment)			
QWEST Central Office			
CO A NI	CO Z NI	Mid-Span NI	End-User NI
Interoffice			
01QBF.LLX	01QBF.LLX (FDP)		
01QBF.LLX		01QBF.LLX (FDP) * #	
01QBF.LLX		01FCF.X (Splice) *	
Loop (Exchange)			
01QBF.LLX			01QBF.LLX (FDP)
01QBF.LLX		01QBF.LLX (FDP) #	

* Available only where permitted by contract. See PUB 77383

This code will be replaced in the near future with a code designating a "Field Location" rather than a "Central Office" location

B.4 Unbundled Switch Elements

Unbundled Switch Elements provide unbundled line-side or trunk-side connections to a QWEST End Office switch. The elements allow for the purchase of individual line-side or trunk-side services. Unbundled Switch Elements provide access to the switching components of QWEST's End Office switch.

This section gives a brief description of several of the elements. PUB 77391, *Unbundled Switch Elements*, should be consulted for further information.

B.4.1 Unbundled Analog Line Port Service

Unbundled Analog Line ports provide access to the basic functionality of an End Office switch, including address digit reception and translations, routing and rating, and call supervision for intra-office switched services. Port switching functions provide for the establishment of a connection between two line ports within the switch (intraoffice) or between an unbundled line port and an unbundled trunk port that connects to another switching entity (interoffice). Analog Line Port functionality is provided by Stored Program Control analog and digital end offices. The ports may be used for business or residential lines.

B.4.2 Unbundled DS1 Trunk Port Service

An Unbundled DS1 Trunk Port is a DS1 trunk side End Office switch port physically terminating at a DS1 common Inter-Connector Distribution Frame (ICDF) or equivalent. Each Unbundled DS1 Trunk Port includes a subset of 24 DS0 channels capable of supporting local message type traffic. This Unbundled DS1 Trunk Port does not support PRI/ISDN or DID/DOD/PBX type of traffic.

Local message type traffic allows communication paths between End Office Switches. A Message Trunk Port provides the switch connection between calling and called parties at the QWEST ICDF frame.

B.4.3 Unbundled Direct Inward Dial Trunk Port Service

The Direct Inward Dialed (DID) Trunk Port is an unbundled switching product that provides a Co-Provider the ability to physically connect a Private Branch Exchange (PBX) user to/from the trunk side of a QWEST Central Office switch.

DID is a special Private Facilities 2-way trunk with line side treatment that permits incoming calls from the exchange network to reach a specific PBX station directly without attendant assistance. DID trunk ports are capable of a DS1 termination in the digital environment or a single circuit metallic termination in the analog environment for a time sensitive temporary connection to the QWEST Central Office switch.

B.4.4 Unbundled Basic Rate ISDN Port Service

An Unbundled Basic Rate Interface (BRI) Integrated Services Digital Network (ISDN) Port provides a 2-wire electrical interface to a QWEST Central Office Switch for the provision of Basic Rate ISDN capabilities. BRI supports a Digital Subscriber Line comprised of two 56 or 64 kbit/s bearer channels and a single 16 kbit/s out-of-band signaling channel for data (2B+D). The BRI port provides access to the functions and capabilities of a QWEST Central Office Switch, including ISDN voice capability, and circuit switched data.

B.4.5 Unbundled Primary Rate ISDN Port Service

An Unbundled Primary Rate Interface ISDN Port provides a DS1 level electrical interface to a QWEST Central Office Switch for the provision of 24 DS0 64 channels. The base configuration consists of 23 64 B channels for End-User voice and/or data traffic and one 64 D channel for out of band signaling control of the B channels.

B.5 Other Unbundled Network Elements

Other UNEs may become available in the future. Information will be added to this publication when available.