

**QWEST Communications  
International Inc.  
Technical Publication**

**QWEST  
Digital Data Service  
2-Wire**

**Copyright 1999, 2001, 2002  
QWEST Communications International Inc.  
All Rights Reserved**

**77399  
Issue C  
June 2002**

## NOTICE

This document describes a brief product description, application information, technical information and Network Channel/Network Channel Interface (NC/NCI) combinations for the QWEST's Digital Data Service 2-wire.

QWEST Communications International Inc. reserves the right to revise this document for any reason, including but not limited to, conformity with standards promulgated by various governmental or regulatory agencies; utilization of advances in the state of the technical arts; or to reflect changes in the design of equipment, techniques, or procedures described or referred to herein.

Liability to anyone arising out of use or reliance upon any information set forth herein is expressly disclaimed, and no representation or warranties, expressed or implied, are made with respect to the accuracy or utility of any information set forth herein.

This document is not to be construed as a suggestion to any manufacturer to modify or change any of its products, nor does this publication represent any commitment by QWEST Communications International Inc. to purchase any specific products. Further, conformance to this publication does not constitute a guarantee of a given supplier's equipment and/or its associated documentation.

Future issues of Technical Publication 77399 will be announced to the industry at least 45 days before the issuance date. This notice, which will come through our standard customer notification channels, will allow the customer time to comment on the proposed revisions.

Ordering information for QWEST Publications can be obtained from the Reference Section of this document.

If further information is required, please contact:

QWEST Communications International Inc.  
Manager – New Services Planning  
700 W. Mineral Ave. MN-G14.27  
Littleton, CO 80120  
(303) 707-7117  
(303) 707-9497 Fax #  
E-mail: [techpub@qwest.com](mailto:techpub@qwest.com)



COMMENTS on PUB 77399

PLEASE TEAR OUT AND SEND YOUR COMMENTS/SUGGESTIONS TO:

QWEST Corporation  
Manager – New Services Planning  
700 W. Mineral Ave. MN-G14.27  
Littleton, CO 80120  
(303) 707-7117  
(303) 707-9497 Fax #  
E-mail: techpub@qwest.com

Information from you helps us to improve our Publications. Please take a few moments to answer the following questions and return to the above address.

Was this Publication valuable to you in understanding The technical parameters of our service?	YES _____ NO _____
Was the information accurate and up-to-date?	YES _____ NO _____
Was the information easily understood?	YES _____ NO _____
Were the contents logically sequenced?	YES _____ NO _____
Were the tables and figures understandable and helpful	YES _____ NO _____
Were the pages legible?	YES _____ NO _____

If you answered NO to any of the questions and/or if you have any other comments or suggestions, please explain:

---

---

---

(Attach additional sheet, if necessary)

Name \_\_\_\_\_ Date \_\_\_\_\_

Company \_\_\_\_\_

Address \_\_\_\_\_

Telephone Number \_\_\_\_\_

E-Mail \_\_\_\_\_

## Contents

<b>Chapter and Section</b>	<b>Page</b>
1. Introduction.....	1-1
1.1 General.....	1-1
1.2 Reason For Reissue.....	1-1
1.3 Scope.....	1-1
1.8 Document Organization.....	1-1
2. Description of Service.....	2-1
2.1 General.....	2-1
2.2 Applications.....	2-1
2.2 DDS 2-wire Line Code.....	2-1
2.4 U Interface.....	2-2
3. Channel and Interface Specifications.....	3-1
3.1 General.....	3-1
3.2 Network Channel (NC) Code Function.....	3-1
3.3 NC Code Components and Format.....	3-1
3.4 DDS 2-wire Service NC Codes.....	3-2
3.5 NCI Code Function.....	3-2
3.6 NCI Code Components.....	3-2
3.7 Compatible Network Channel Interface (NCI) Code Combinations.....	3-3
4. Technical Specifications IDSL Private Line Service.....	4-1
4.1 General.....	4-1
4.2 IDSL Private Line Service.....	4-1
4.3 ISDN “U” Interface Channel Unit.....	4-2
4.4 Error Performance Parameters.....	4-3
4.4.1 Bit Error Ratio (BER).....	4-3
4.4.2 Errored Second (ES).....	4-3
4.4.3 Severely Errored Second (SES).....	4-3
4.5 Error Performance.....	4-3
4.6 Service Availability.....	4-4
4.7 Normalized Pulse at Network Interfaces.....	4-4
4.8 Upper Bound of Power Spectral Density of Signal at Network Interfaces.....	4-5
4.9 Applied Power Level.....	4-6
4.10 Sealing Current.....	4-6

**Contents (Continued)**

<b>Chapter and Section</b>	<b>Page</b>
5. Maintenance.....	5-1
5.1 Customer Responsibilities.....	5-1
5.2 QWEST Responsibilities .....	5-1
6. Definitions .....	6-1
6.1 Acronyms.....	6-1
6.2 Glossary .....	6-2
7. References.....	7-1
7.1 American National Standards Institute Documents .....	7-1
7.2 Institute of Electrical and Electronics Engineers Publications.....	7-1
7.3 International Telecommunication Union Recommendations.....	7-1
7.4 QWEST Publications.....	7-1
7.5 Federal Communications Commission Documents .....	7-2
7.6 Telcordia Documents.....	7-2
7.7 Ordering Information.....	7-2
7.8 Trademarks.....	7-3

**Tables**

1-1 Document Organization.....	1-1
3-1 Available DDS 2-wire Service Network Channel Codes .....	3-2
3-2 Available DDS 2-wire Service Network Channel Interface Codes.....	3-3
3-3 DDS 2-wire Service, Access NC/NCI Code Combinations .....	3-3
3-4 DDS 2-wire Service, IntraLATA NC/NCI Code Combinations .....	3-4
4-1 IDSL Private Line Service Long-Term Accuracy and Availability Objectives .....	4-3

**Figures**

2-1 Block Diagram of Service .....	2-1
3-1 Format Structure for NC Codes .....	3-1
3-2 NCI Code Components .....	3-2
4-1 Typical IDSL Private Line Service .....	4-1
4-2 Complex example of an IDSL Private Line Service Configuration.....	4-2
4-3 Normalized Pulse from an NT or LT Transmitter .....	4-5
4-4 Maximum Power Spectral Density Mask.....	4-6

## CONTENTS

<b>Chapter and Section</b>	<b>Page</b>
1. Introduction.....	1-1
1.1 General.....	1-1
1.2 Reason For Reissue .....	1-1
1.3 Scope.....	1-1
1.8 Document Organization.....	1-1

### **Table**

1-1 Document Organization.....	1-1
--------------------------------	-----





## 1. Introduction

### 1.1 General

This document describes a brief product description, application information, technical information and Network Channel/Network Channel Interface (NC/NCI) combinations for the QWEST's Digital Data Service 2-wire (DDS 2-wire).

### 1.2 Reason For Reissue

This issue is published to distinguish the difference in ISDN and IDSL technologies used for DDS 2-Wire and DSL services.

### 1.3 Scope

The intent of this document is to provide End-Users (EU's), service providers, and equipment manufacturers with a description of QWEST's Digital Data Service 144 Kilo Bits per Second, its operational characteristics and available network interfaces.

### 1.4 Document Organization

Table 1-1 describes how this document is organized.

**Table 1-1** Document Organization

<b>Chapter</b>	<b>Title</b>	<b>Contents</b>
1	Introduction	General information about this document
2	Service Description	Description of the service
3	Channel and Interface Specifications	Explanation of interface codes and valid code combinations
4	Technical Specifications - Digital Unbundled Loops	Technical issues and operational characteristics of Digital Subscriber Lines
5	Maintenance	Customer and QWEST Responsibilities
6	Definitions	Acronyms and glossary of terms
7	References	List of references with ordering instructions and a list of Trademarks

## CONTENTS

<b>Chapter and Section</b>	<b>Page</b>
2. Description of Service.....	2-1
2.1 General.....	2-1
2.2 Applications .....	2-1
2.2 DDS 2-wire Line Code.....	2-1
2.4 U Interface .....	2-2
<b>Figure</b>	
2-1 Block Diagram of Service .....	2-1



## 2. Description of Service

### 2.1 General

This chapter provides a brief description of QWEST DDS 2-wire Service.

The Digital Data Service 144 KiloBits per Second (DDS 2-wire) provides for IntraLATA and Special Access, Point to Point DDS kbit/s Private Lines. The QWEST DDS 2-wire Service provides a full duplex channel with the capability of transmitting 2-wire of digital data. QWEST DDS 2-wire Service consists of a 160 kbit/s channel for the transmission of a serial 2-wire, 2B+D of bi-directional customer data, plus one bi-directional 16 kbit/s channel to support provisioning and maintenance operations. The channel will support terminal equipment designed in accordance with ANSI T1.601-1992.

The DDS 2-wire Private Line consists of an End-User (EU) Network Interface, and a transport channel connecting to either another EU Network Interface or a Network Interface at an Interexchange Carrier's Point of Termination (POT).

### 2.2 Applications

DDS 2-wire applications include:

- ISDN off-premises extensions for ISDN Private Branch Exchange (PBX)
- Private Line connections to Internet Service Providers (ISPs) or Enhanced Service Providers (ESPs)

### 2.2 DDS 2-wire Line Code

The DDS 2-wire line code shall be 2B1Q (2 binary, 1 quaternary) nominally operating at 160 kbit/s with channelized user data rate comprising of two 64-kbit/s B-channels and a 16-kbit/s D-channel. 16 kbit/s is reserved for network performance data.

Central Office Line Driver Unit: This is an electronic device that ensures the signal leaving the central office meets all of the transmission parameters specified in Telcordia Technical Reference, TR-TSY-000393, "ISDN Basic Access Digital Subscriber Lines," ANSI T1.601-1992, *Telecommunications-Integrated Services Digital Network (ISDN)- Basic Access Interface for Use on Metallic Loops for Application on the Network side of the NT (Layer 1 Specification)* .

The transmission path's facility is consistent with Telcordia Technical Reference, TR-TSY-00393, ISDN Basic Access Digital Subscriber Lines and ANSI T1.601.1992, *Telecommunications - Integrated Services Digital Network (ISDN) Basic Access Interface for Use on Metallic Loops for Application on the Network Side of the NT (Layer 1 Specification)*.

Therefore, when Qwest refers to ISDN or IDSL (xDSL-I) in Wholesale documentation, including the Product Catalog (PCAT), Technical Publications or the LSOG/ASOG documentation, they are referring to the same physical facility capabilities. CLECs can use these terms interchangeably, ONLY when talking about Loop Qualification or facility capabilities. Likewise, the loop make-up information in the RLD tool will indicate the same physical make-up for ISDN or IDSL requests.

The difference between ISDN and IDSL is that each can require specific transmission equipment in the CO to generate the appropriate signal. Although the facilities offer the same payload

(144kbps), the equipment causes the distinction in the signal (i.e., ISDN = 2B+D channelized signal vs. IDSL = full payload un-channelized signal).

Figure 2-1 below is a high-level block diagram of the service.

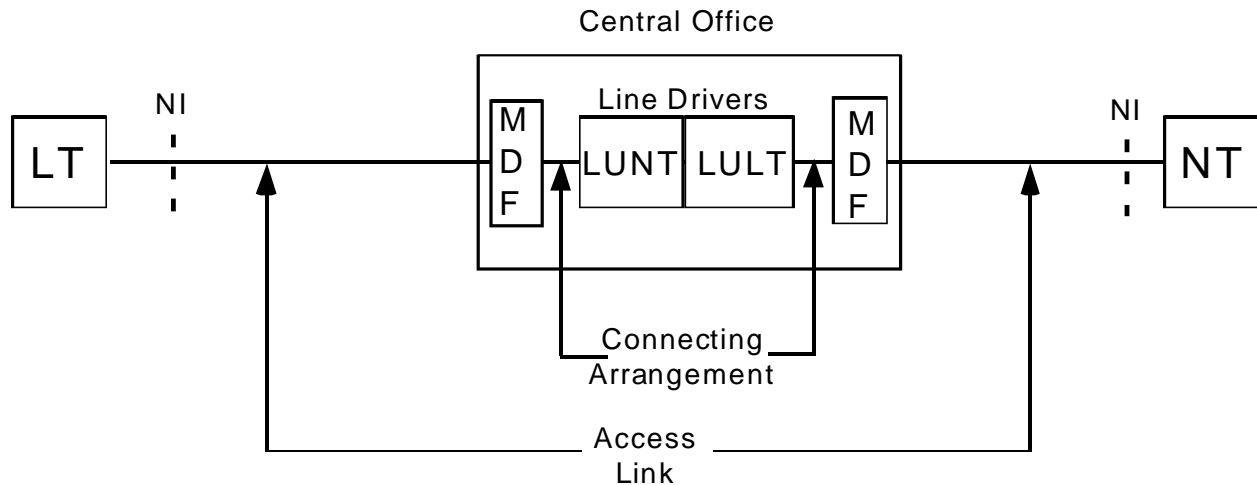

**Figure 2-1** Block Diagram of Service

## 2.4 U Interface

A complete, DDS 2-wire circuit consists of a Line Termination (LT), a Network Termination (NT) and the connecting channel. Typically, the LT refers to equipment that terminates the DDS 2-wire path in a switch. The NT refers to equipment that terminates the DDS 2-wire in station or End User equipment. The location of the interface between the network facility and the customer's terminal equipment is commonly known as the U interface. The equipment on the customer side of a U interface is known as the NT.

The relative position of the LT and NT interfaces is essential in designing the connecting channel. Customers must indicate, through specifying appropriate Network Channel Interface codes, the LT and NT positions.

## CONTENTS

<b>Chapter and Section</b>	<b>Page</b>
3. Channel and Interface Specifications .....	3-1
3.1 General .....	3-1
3.2 Network Channel (NC) Code Function.....	3-1
3.3 NC Code Components and Format.....	3-1
3.4 DDS 2-wire Service NC Codes .....	3-2
3.5 NCI Code Function.....	3-2
3.6 NCI Code Components .....	3-2
3.7 Compatible Network Channel Interface (NCI) Code Combinations .....	3-3

### Tables

3-1 Available DDS 2-wire Service Network Channel Codes .....	3-2
3-2 Available DDS 2-wire Service Network Channel Interface Codes.....	3-3
3-3 DDS 2-wire Service, Access NC/NCI Code Combinations .....	3-4
3-4 DDS 2-wire Service, IntraLATA NC/NCI Code Combinations .....	3-4

### Figures

3-1 Format Structure for NC Codes .....	3-1
3-2 NCI Code Components .....	3-2



### 3. Channel and Interface Specifications

#### 3.1 General

Network Channel (NC) codes describe, in standard format, the characteristics of the service channel. Network Channel Interface (NCI) codes describe the physical and electrical characteristics of the Network Interface (NI). *Industry Support Interface (ISI); NC/NCI Code Dictionary*, Telcordia Special Report SR-STIS-000307 fully describes these coding schemes.

#### 3.2 Network Channel (NC) Code Function

Service considerations are encoded into NC codes. The Carrier or End-User specifies the NC Code to advise QWEST of the required service connection of the channel and of any applicable Central Office (CO) functions.

#### 3.3 NC Code Components and Format

An NC code is a four-character code with two data elements:

- Channel Code
- Optional Feature Code

Figure 3-1 illustrates NC code format.

Network Channel Code				
Data Element	Channel Code		Optional Feature Code	
Character Position	1	2	3	4
Character Key	X	X	X or -	X or -

- X = Alphanumeric
- = Hyphen

**Figure 3-1: Format Structure for NC Codes**

The **Channel Code** (character positions 1 and 2) is a two character alpha or alphanumeric code that describes the channel service in an abbreviated form. The channel code will frequently, but not always, be the service code of special service circuits or the transmission grade of message trunk circuits. The NC channel code field is always filled.

The **Optional Feature Code** (character positions 3 and 4) is a two character alpha or alphanumeric or hyphen code that represents the option codes available for each channel code. Varying combinations of this code will allow the customer to enhance the technical performance of the requested channel, or to further identify the type of service. It can also specify options such as data conditioning, bridging, etc. The NC optional code field is always filled.



### 3.4 DDS 2-wire Service NC Codes

For Digital Data Service (DDS) 2-wire, the first two characters are AD. The third and fourth characters denote additional service features.

Table 3-1 contains the available NC codes for DDS 2-wire Service channels.

**Table 3-1: Available DDS 2-wire Service Network Channel Codes**

Network Channel Code	Point-to-Point DDS 2-wire Service Description
<b>Digital Subscriber Line</b>	
AD--	Digital Subscriber Line, nominally 160 kbit/s (144 kbit/s payload)

### 3.5 NCI Code Function

The NCI code is an encoded representation used to identify five interface elements located at a Point Of Termination (POT) at the CO or at the EU's location. The interface elements are physical conductors, protocol, impedance, protocol options and Transmission Level Points (TLPs).

### 3.6 NCI Code Components

An DDS 2-wire Service NCI Code has four components as shown in Figure 3-2:

This example is an NCI code for a Basic Rate ISDN (Switch) interface at a Central Office.

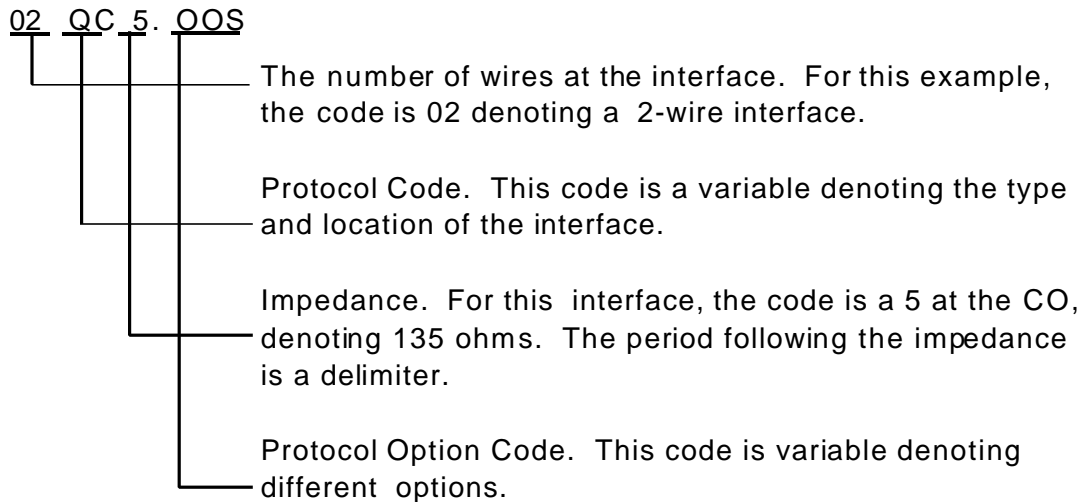

**Figure 3-2: NCI Code Components**

**Table 3-2** Available DDS 2-wire Service Network Channel Interface Codes

Network Channel Interface Codes	Description
<b>End- User Interfaces</b>	
02IS5.L	160 kbit/s, 2B1Q Signaling Format, U interface
	Presents Line Termination (LT) Function to Network
02IS5.N	Presents Network Termination (NT) Function to Network
<b>QWEST C.O Interfaces</b>	
	Manual Cross-Connect, DS0/Voice Termination
02QC5.OOS	160 kbit/s, 2B1Q Signaling Format, U interface
	Presents Line Termination (LT) Function to Network
02QC5.OOV	Presents Network Termination (NT) Function to Network

### 3.7 Compatible Network Channel Interface (NCI) Code Combinations

This section provides code combinations used to order DDS 2-wire Service interfaces and services of the following types:

- Point-to-Point DDS 2-wire Service
- Special Access DDS 2-wire Service

Tables 3-3 and 3-4 list NC/NCI Code combinations for DDS 2-wire Service

**Table 3-3: DDS 2-wire Service, Access NC/NCI Code Combinations**

NC Code	NCI Code			Channel Description
	Access Cust.	U S WEST CO-NI	End-User EU-NI	
<b>Co-Providers</b>				
AD-	n.a.	02QC5.OOS	02IS5.N	IDSL with 2B1Q Signaling Format, NT function at EU
-				
AD-	n.a.	02QC5.OOV	02IS5.L	IDSL with 2B1Q Signaling Format, LT function at EU
-				
<b>Interexchange Carriers</b>				
AD-	Digital	n.a.	02IS5.N	IDSL with 2B1Q Signaling Format, NT function at EU
-				
AD-	Digital	n.a.	02IS5.L	IDSL with 2B1Q Signaling Format, LT function at EU
-				

Note: 1. Digital denotes any valid NCI code for DS1 or higher rate service. DS1s shall use only B8ZS Line Code.  
2. Not Applicable = n.a.

An Access Customer is any of the various companies that provide telecommunications service between LATAs and order from Access Tariffs. This includes Interexchange Carriers.

**Table 3-4: DDS 2-wire Service, IntraLATA NC/NCI Code Combinations**

NC Code	NCI Code		Channel Description
	End-User A-End EU-NI	End-User Z-End EU-NI	
AD--	02IS5.L	02IS5.N	IDSL with 2B1Q Signaling Format
AD--	02IS5.N	02IS5.L	IDSL with 2B1Q Signaling Format

## CONTENTS

Chapter and Section	Page
4. Technical Specifications DDS 2-wire Service.....	4-1
4.1 General.....	4-1
4.2 DDS 2-wire Service.....	4-1
4.3 ISDN “U” Interface Channel Unit.....	4-2
4.4 Error Performance Parameters .....	4-3
4.4.1 Bit Error Ratio (BER) .....	4-3
4.4.2 Errored Second (ES) .....	4-3
4.4.3 Severely Errored Second (SES).....	4-3
4.5 Error Performance.....	4-3
4.6 Service Availability .....	4-4
4.7 Normalized Pulse at Network Interfaces .....	4-4
4.8 Upper Bound of Power Spectral Density of Signal at Network Interfaces.....	4-5
4.9 Applied Power Level .....	4-6
4.10 Sealing Current.....	4-8

### Figures

4-1 Typical DDS 2-wire Service.....	4-1
4-2 Complex example of an DDS 2-wire Service Configuration.....	4-3
4-3 Normalized Pulse from an NT or LT Transmitter .....	4-5
4-4 Maximum Power Spectral Density Mask.....	4-6

### Tables

4-1 DDS 2-wire Service Long-Term Accuracy and Availability Objectives.....	4-4
---	-----



## 4. Technical Specifications Digital Data Service 2-wire Service

### 4.1 General

This chapter details the technical characteristics; available configurations and transmission performance characteristics for the Digital Data Service 2-wire (DDS 2-wire) Service NCIs listed in Table 3-2.

### 4.2 DDS 2-wire Service

Figure 4-1 illustrates a typical 2-Wire, DDS 2-wire Service.

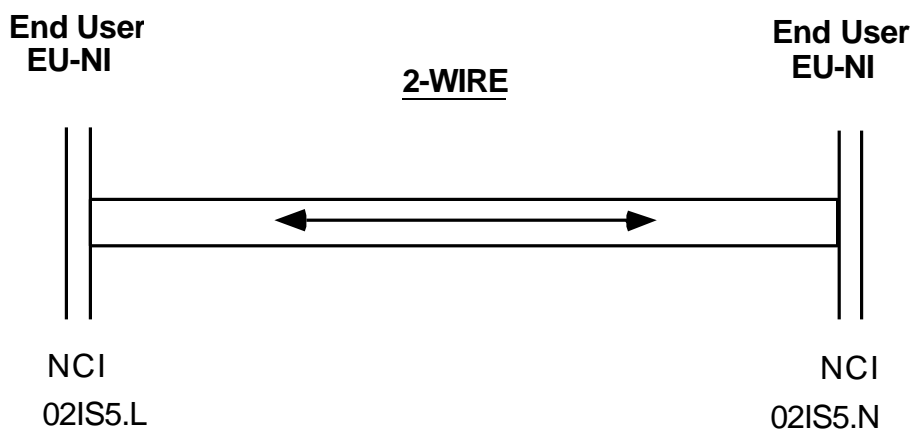

**Figure 4-1:** Typical DDS 2-wire Service

The DDS 2-wire Service is a QWEST provided channel with at least one, two-wire (U) interface that provides connectivity from a Network Interface at an end user's location (EU-NI) to a corresponding EU-NI at a different location. This Service may also be a Special Access service segment where QWEST provides a channel from an EU-NI (a U interface) to a Carrier's Point of Termination NI which may be a high capacity interface. The two-wire, U interface loop design, limits the length of the loop to an Actual Measured Loss (AML) of 42 dB at 40 kHz using 135 Ohm terminations.

The EU-NI is typically a Network Interface Device or NID. The NID divides the QWEST facility and the EU's customer installation, i.e., inside wiring and customer premises equipment. The transmission path's facility is consistent with Telcordia Technical Reference, TR-TSY-00393, *ISDN Basic Access Digital Subscriber Lines and ANSI T1.601.1992, Telecommunications - Integrated Services Digital Network (ISDN) Basic Access Interface for Use on Metallic Loops for Application on the Network Side of the NT (Layer 1 Specification)*. They terminate using digital interfaces.

The DDS 2-wire Service from the QWEST Serving Central Office to the EU-NI has one of the following configurations:

- Non loaded metallic loop that is qualified for DDS 2-wire transmission.
- A Central Office range extension unit for a long, non-loaded metallic loop.
- A combination of Subscriber Loop Carrier channels and a non-loaded metallic loop.
- A combination of a long non-loaded metallic loop, a mid-span regenerator and Central Office power unit.

There are some end user locations served by facilities and transmission equipment that are not compatible with the DDS 2-wire Service technical requirements. QWEST shall process requests DDS 2-wire Service for these locations on an Individual Case Basis.

Inter-Office transport segments will consist of DS1, channelized facilities using ISDN Channel units as described below.

### **4.3 ISDN “U” Interface Channel Unit**

These channel units are known by several names frequently based on the term Basic Rate Interface Transmission Extension or “BRITE”. The cards are designed to feed the DDS 2-wire service, 2B+D signal on a two-wire metallic non-loaded loop.

This channel unit provides an ISDN 2B1Q, U interface which meets all Layer 1 requirements as specified in ANSI T1.601-1992, *Telecommunications - Integrated Services Digital Network (ISDN) - Basic Access Interface for use on Metallic Loops for Application on the Network Side of the NT (Layer 1 Specification)*. Transportation of DDS 2-wire Service 2B+D customer payload over DS1 facilities in the 3-DS0 format specified in TR-NWT-000397, *ISDN Basic Access Transport System Requirements*.

These channel units use D4 counting in slot usage. The 2B+D channel capacity uses three time slots on the DS1 and three slots in the channel bank. Therefore, the ISDN channel unit can not be placed in slots 23 or 24 of a conventional D4 type channel bank.

Proper operation requires that matching equipment be synchronized to a clock traceable to a Stratum 1 source.

ISDN “U” type channel units have to be optioned for their termination mode function, either Line Termination (LT) or Network Termination (NT). Figure 4-2 is a simplification of a figure from ANSI T1.601-1992, Annex E. NI #1 is located in one wire center. The second NI is located in a second wire center. The third NI is located at the customer’s location. Consult ANSI T1.601-1992 for further information. The relative position of the LT and NT interfaces is essential in designing the connecting channel. Customers must indicate, through specifying appropriate Network Channel Interface codes in Chapter 3, the LT and NT positions.

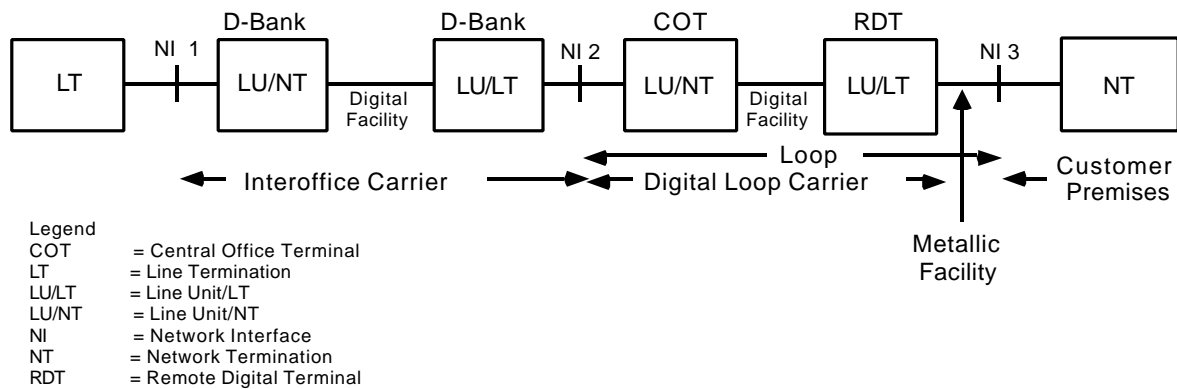

**Figure 4-2: Complex example of an DDS 2-wire Service Configuration**

#### 4.4 Error Performance Parameters

Error performance parameters are:

##### 4.4.1 Bit Error Ratio (BER)

The ratio of the number of bit errors to the total number of bits transmitted in a given time interval.

##### 4.4.2 Errored Second (ES)

An Errored Second is any one-second interval containing at least one error.

##### 4.4.3 Severely Errored Second (SES)

A one-second period having a Bit Error Ratio of  $10^{-3}$  or worse.

**Note:** A period of loss of signal shall be considered a period of errored bits.



#### 4.5 Error Performance

Objectives given in this section are for all one-way system options, designed consistent with standard architectures and apply at maximum short-haul design length. For DDS 2-wire Service, the long-term percentage of Error Free Seconds (the measure of accuracy) and Availability are shown in Table 4-2. These objectives apply in normal operating environments and only for the QWEST provided portion of a service.

**Table 4-1: DDS 2-wire Service Long-Term Accuracy and Availability Objectives**

Transport Segment	IDSL 160 Kbit/s
<b>Availability</b>	
End-to-End	99.65 %
Access	99.90 %
<b>Accuracy - Error Free Seconds</b>	
End-to-End	99.50 %
Access	99.75 %

Accuracy performance shall be evaluated relative to a measurement period of 30 days or more. The long-term accuracy objectives are expressed as a ratio (or percentage) because they apply over long periods of time.

Loopback tests should be made using the one-way limits because one direction is likely to be controlling. If these tests fail, the failed direction should be sectionalized and appropriate one-way tests made.

#### 4.6 Service Availability

The service is available when it is in a state where it is fully useable. A service is assumed to be in the available state unless a transition to the unavailable state is observed without a subsequent transition to the available state.

Transitions between the available and unavailable states are:

- Transition to the Unavailable state occurs at the beginning of 10 consecutive SES.
- Transition to the Available state occurs at the beginning of 10 consecutive seconds none of which is an SES.

Each direction of a service is assumed to be in the available state unless a transition to the unavailable state is observed without a subsequent transition to the available state.

#### **4.7 Normalized Pulse at Network Interfaces**

Maximum voltage of transmitted pulse at a Network Interface shall have a shape and normalized (relative to peak) magnitude as specified in Figure 4-3, below. Compliance of transmitted pulses with the pulse mask is not sufficient to assure compliance with the power density requirement.

The received pulse at the Network Interface may be attenuated by a length of cable extending from the QWEST Central Office to the End User premises. It will conform to the U interface specifications of ANSI T1.601-1992, *Telecommunications-Integrated Services Digital Network (ISDN)- Basic Access Interface for Use on Metallic Loops for Application on the Network side of the NT (Layer 1 Specification)*.

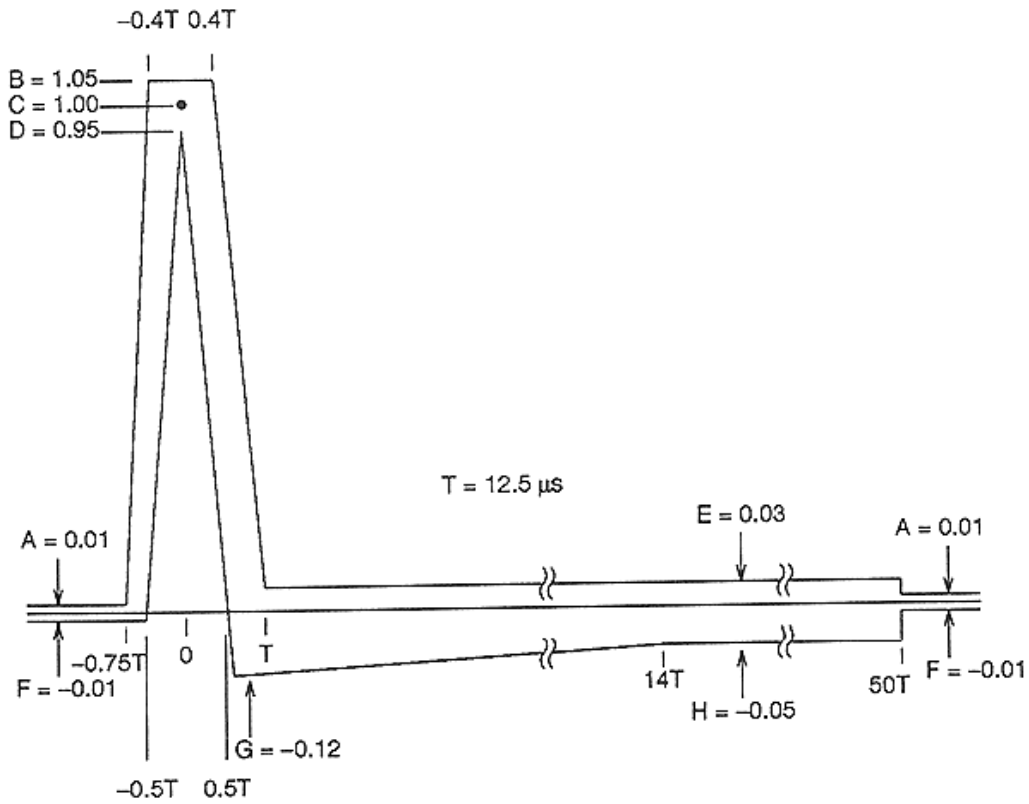

Normalized level:	Quaternary symbols:				
	+3	+1	-1	-3	
A	0.01	0.025 V	0.00833 V	-0.00833 V	-0.025 V
B	1.05	2.625 V	0.8750 V	-0.8750 V	-2.625 V
C	1.00	2.5 V	5/6 V	-5/6 V	-2.5 V
D	0.95	2.375 V	0.79167 V	-0.79167 V	-2.375 V
E	0.03	0.075 V	0.025 V	-0.025 V	-0.075 V
F	-0.01	-0.025 V	-0.00833 V	0.00833 V	0.025 V
G	-0.12	-0.3 V	-0.1 V	0.1 V	0.3 V
H	-0.05	-0.125 V	-0.04167 V	0.04167 V	0.125 V

Figure 4-3: Normalized Pulse from an NT or LT Transmitter

#### 4.8 Upper Bound of Power Spectral Density of Signal at Network Interfaces

The upperbound of the average power spectral density (PSD) of the signal transmitted by any DDS 2-wire transmitter shall be as shown in Figure 4.4 below.

This PSD template is intended to conform with the Very Low-Band Symmetric Class of digital subscriber line transport as developed by the Accredited Standards Committee on-Telecommunications. Technical Subcommittee T1E1 is developing an ANSI Standard for Spectrum Compatibility. It is QWEST's intention that the DDS 2-wire Service shall employ interfaces that conform to the emerging Standard. The working Draft Standard for Spectral Compatibility is Standards Project T1E1.4, Document T1E1.4/99-002.

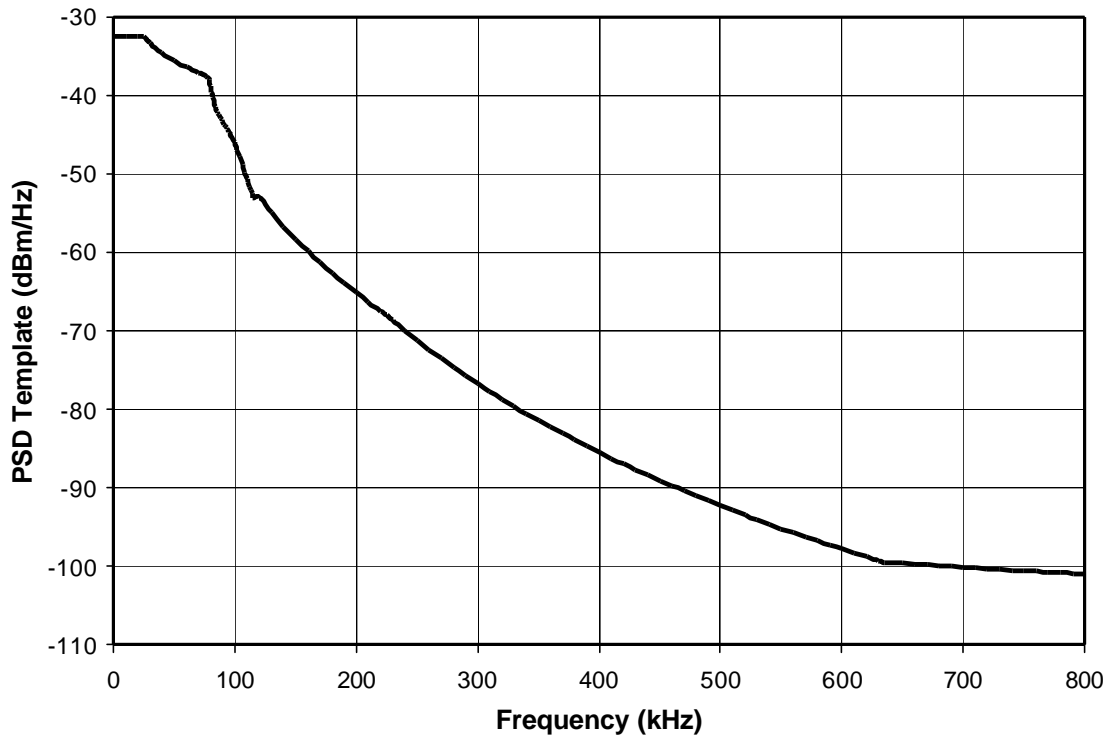

**Figure 4-4: Maximum Power Spectral Density Mask**

#### **4.9 Applied Power Level**

The applied power level of any transmitted signal must comply with American National Standards Institute (ANSI) specifications T1.401-1993 and Telcordia's Generic Requirements 1089-CORE, *Electromagnetic compatibility and Electrical Safety Generic Criteria for Network Telecommunications Equipment*. Continuous idle-state voltages applied to the CO-NI and EU-NI must fall within the range of 0 to 105 volts DC with respect to ground potential.

The transmitted signal must be one that complies with the Spectral Compatibility Standard under development by the Accredited Standards Committee on Telecommunications, T1, Working Group T1E1.4. While this document is in its final stages of development, the power spectrum template is readily available and well known by manufacturers in the industry

#### **4.10 Sealing Current**

Sealing current may be supplied by QWEST from the central office to the customer premises. See ANSI T1.601-1992 for additional information, This sealing current shall not be used for powering customer terminal equipment.

## CONTENTS

<b>Chapter and Section</b>	<b>Page</b>
5. Maintenance.....	5-1
5.1 Customer Responsibilities.....	5-1
5.2 QWEST Responsibilities .....	5-1



## **5. Maintenance**

### **5.1 Customer Responsibilities**

The Customer is responsible for all equipment and cable on their sides of the Network Interfaces (NIs).

The Customer or their responsible agent must sectionalize trouble conditions and verify that the trouble is not in End User (EU) or other Carrier owned equipment or cabling before calling the applicable QWEST Repair Center. The Customer must provide QWEST with this information before QWEST will dispatch to repair.

QWEST will furnish the Customer a trouble reporting telephone number.

If the trouble is isolated to EU owned equipment or cable, the EU is responsible for clearing the trouble and restoring the service to normal.

Joint testing between the Customer and QWEST may occasionally be necessary to isolate trouble.

### **5.2 QWEST Responsibilities**

QWEST is responsible for all equipment and cable between EU-Network Interfaces (NI) in IntraLATA Private Line circuits or between the QWEST side of the Carrier Point of Termination and the EU-NI in Special Access circuits.

Upon receipt of a trouble report, QWEST, Inc. will initiate actions as specified in the Service Interval Guide to clear the trouble.



## CONTENTS

<b>Chapter and Section</b>	<b>Page</b>
6. Definitions .....	6-1
6.1 Acronyms .....	6-1
6.2 Glossary .....	6-2



## 6. Definitions

### 6.1 Acronyms

AML	Actual Measured Loss
ANSI	American National Standards Institute
BER	Bit Error Ratio
CFA	Carrier Facility Assignment
CLLI™	COMMON LANGUAGE Location Identification
CO	Central Office
CO-NI	Central Office Network Interface
dB	Decibel
DS1	Digital Service Level 1
EI	Electrical Interface
ES	Errored Second
ESP	Enhanced Service Provider
EU	End-User
EU-NI	End-User Network Interface
ISDL	ISDN Digital Subscriber Line
ISDN	Integrated Services Digital Network
ISP	Internet Service Provider
kbit/s	Kilobits per Second (1,000 bit/s)
LATA	Local Access and Transport Area
LT	Line Termination
LULT	Line Unit LT
LUNT	Line Unit NT1
Mbit/s	Megabits per Second (1,000,000 bit/s)
NC	Network Channel
NCI	Network Channel Interface
NI	Network Interface

NT	Network Termination
NT1	Network Termination 1
PBX	Private Branch Exchange
POT	Point Of Termination
PSD	Power Spectral Density
SES	Severely Errored Second
TLP	Transmission Level Point
VF	Voice Frequency

## 6.2 Glossary

### Bandwidth

Analog - The range of frequencies that contain most of the energy or power of a signal; also, the range of frequencies over which a circuit or system is designed to operate.

Digital - The amount of information that a signal can carry over a fixed time interval. A system with a high bandwidth can carry more information over a fixed time interval than a low bandwidth system.

### 2B1Q

Two Binary One Quaternary. A four-level pulse amplitude modulation line code that converts 2 bit binary pairs into quaternary symbols.

### Binary *n*- Zero Substitution (**B*n*ZS**)

Binary *n*- Zero Substitution is an application of BPRZ, and is an exception to the Alternate Mark Inversion (AMI) line-code rule. It is one method for providing bit independence for digital transmission, by providing a minimum 1's density of 1 in *n*-bits. For DS3, *n*=3; for DS1, *n*=8; for 56 kbit/s service, *n*=7, and for subrates, *n*=6. The rule of B*n*ZS is:

- Successional binary 1s (Marks) will be of opposite polarity (AMI) unless they are separated by *n* consecutive binary zeros, in which case the *n* 0s will be replaced by an *n*-bit byte containing 1s, having or causing, an intentional bipolar violation (bpv).
- For example in B6ZS, if the preceding binary 1 was +, then binary 100000011 is transmitted as signal voltage values: -000+0++ (the B6ZS byte is underlined). Assume the leftmost bit is transmitted first.

- In the decoding process, the *BnZS* signature is recognized and replaced by an all zero *n*-bit byte.

### **Bit (Binary Digit)**

A binary unit of information. It is represented by one of two possible conditions, such as the value 0 or 1, on or off, high potential or low potential, conducting or not conducting, magnetized or demagnetized. A Bit is the smallest unit of information, by definition.

### **Central Office (CO)**

A local switching system (or portion thereof) and its associated equipment located at a wire center.

### **Channel**

An electrical or photonic (in the case of fiber optic based transmission systems) communications path between two or more points of termination.

### **End-User (EU)**

The term "End-User" denotes any customer of telecommunications service that is not a carrier; except that a carrier shall be deemed to be an "End-User" to the extent that such carrier uses a telecommunications service for administrative purposes, without making such service available to others, directly or indirectly. The term is frequently used to denote the difference between a carrier interface and an interface subject to unique regulatory requirements at non-carrier customer premises (Federal Communications Commission Part 68, etc.).

**Extended Superframe (ESF) Format**  
An Extended Superframe consists of twenty-four consecutive DS1 frames. Bit one of each frame (the F-bit) is time shared during the 24 frames to describe a 6 bit frame pattern, a 6 bit Cyclic Redundancy Check (CRC) remainder, and a 12 bit data link. The transfer rate of each is 2 kbit/s, 2 kbit/s, and 4 kbit/s respectively.

### **IDSL**

ISDN Digital Subscriber Line. One of a family of Digital Subscriber Lines with a line rate of 160 kbit/s and a maximum customer payload of 144 kbit/s using 2B1Q line coding.

### **ISDN**

Integrated Services Digital Network. An access arrangement consisting of any of the following combinations of access channels.

- one D- channel (16 kbit/s)
- one B- channel plus one D- channel (64 kbit/s + 16 kbit/s)
- two B- channel plus one D- channel (128 kbit/s + 16 kbit/s)

### **Network Channel (NC) Code**

The Network Channel (NC) code is an encoded representation used to identify both switched and non-switched channel services. Included in the code set are customer options associated with individual channel services, or feature groups and other switched services.

### **Network Channel Interface (NCI) Code**

The Network Channel Interface (NCI) code is an encoded representation used to identify five (5) interface elements located at a Network Interface at a customer location. The Interface code

elements are: Total Conductors, Protocol, Impedance, Protocol Options, and Transmission Level Points (TLP).

**Network Interface (NI)**

The point of demarcation on the End-User's premises at which the U S WEST Communications, Inc.'s responsibility for the provision of Access or Non-Access service ends.

**Protocol Code**

The Protocol (character positions 3 and 4 of the NCI Code) is a two-character alpha code that defines requirements for the interface regarding signaling and transmission.

**Superframe Format (SF)**

A superframe consists of 12 consecutive DS1 frames. Bit one of each frame (the F-bit) is used to describe a 12-bit framing pattern during the 12 frames.

## CONTENTS

<b>Chapter and Section</b>	<b>Page</b>
7. References .....	7-1
7.1 American National Standards Institute Documents .....	7-1
7.2 Institute of Electrical and Electronics Engineers Publications.....	7-1
7.3 International Telecommunication Union Recommendations.....	7-2
7.4 QWEST Publications.....	7-2
7.5 Federal Communications Commission Documents .....	7-2
7.6 Telcordia Documents.....	7-2
7.7 Ordering Information.....	7-3
7.8 Trademarks .....	7-4





## 7. References

### 7.1 American National Standards Institute Documents

- ANSI T1.102-1993      *Telecommunications - Digital Hierarchy - Electrical Interfaces*
- ANSI T1.107-1995      *Telecommunications - Digital Hierarchy -Formats Specifications*
- ANSI T1.223-1991      *Telecommunications - Information Interchange-Structure and Representation of Network Channel (NC) and Network Channel Interface (NCI) Codes for the North American Telecommunications System.*
- ANSI T1.403-1995      *Telecommunications - Carrier to Customer Installation, DSI Metallic Interface*
- ANSI T1.510-1994      *Telecommunications - Network Performance Parameters for Dedicated Digital Services -- Specifications*
- ANSI T1.601-1992      *Telecommunications -Integrated Services Digital Network (ISDN) - Basic Access Interface for Use on Metallic Loops for Application on the Network side on the NT (Layer 1 Specification).*
- ANSI T1.605-1991      *Telecommunications -Integrated Services Digital Network (ISDN) -Basic Access Interface for S and T Reference Points (Layer 1 Specification).*

### 7.2 Institute of Electrical and Electronics Engineers Publications

- IEEE Std 100-1992      *The New IEEE Standard Dictionary of Electrical and Electronics Terms [Including Abstracts of All Current IEEE Standards].* Institute of Electrical and Electronics Engineers, Inc. Copyright © 1993.

### 7.3 International Telecommunication Union Recommendations

- G.701                      *Vocabulary of Digital Transmission, Multiplexing and Pulse code Modulation (PCM) Terms*
- I.411                        *ISDN User-Network Interfaces -Reference Configurations*

### 7.4 QWEST Publications

- Service Interval Guide      Updated twice yearly. This is also available through the Interconnect Services Center.
- PUB 77200                *QWEST DSI Service and QWEST DSI Rate Synchronization Service,* Issue F, September 2001
- PUB 77386                *Expanded Interconnection and Collocation for Private Line Transport and Switched Access Services.* Issue F, June 2001
- PUB 77375                *1.544 Mbit/s Channel Interfaces.* Issue E, September 2001

## 7.5 Federal Communications Commission Documents

Code of Federal Regulations 47, Part 68.

## 7.6 Telcordia Documents

GR-499-CORE	Bellcore, <i>Transport Systems Generic Requirements (TSGR): Common Requirements</i> ,
GR-1089-CORE	<i>Electromagnetic compatibility and Electrical Safety Generic Criteria for Network Telecommunications Equipment</i>
SR-STS-000307	Bellcore, <i>Industry Support Interface (ISI): NC/NCI Code Dictionary</i> , Issue 4, February 1993.
TR-NWT-000393	Bellcore, <i>ISDN Basic Access Digital Subscriber Lines</i> .
TR-NWT-000397	Bellcore, <i>ISDN Basic Access Transport System Requirements</i> .

## 7.7 Ordering Information

All documents are subject to change and their citation in this document reflects the most current information available at the time of printing. Readers are advised to check status and availability of all documents.

Ordering Information for those who are not QWEST employees:

For American National Standards Institute (ANSI) documents contact:

American National Standards Institute  
Attn.: Customer Service  
11 West 42nd Street  
New York, NY 10036  
Phone: (212) 642-4900  
Fax: (212) 302-1286  
HTTP URL: <http://www.ansi.org>

ANSI has a catalog available that describes their publications.

For Telcordia documents contact:

Telcordia Customer Relations  
8 Corporate Place, PYA 3A-184  
Piscataway, NJ 08854-4156  
Fax: (908) 336-2559  
Phone: (800) 521-CORE (2673) (U.S. and Canada)  
Phone: (908) 699-5800 (Others)  
HTTP URL: <http://www.telcordia.com>

For IEEE documents contact:

Institute of Electrical and Electronics Engineers, Inc.  
345 East 47th Street  
New York, NY 10017-2394  
HTTP URL: <http://www.ieee.org>

For International Telecommunications Union documents contact:

International Telecommunications Union  
General Secretariat  
Place des Nations, CH-1211  
Geneva 20, Switzerland  
HTTP URL: <http://www.itu.ch>

For QWEST Technical Publications contact:

<http://www.qwest.com/techpub>

For Federal Communications Commission (FCC) documents contact:

Superintendent of Documents  
Government Printing Office  
Washington, D. C. 20402  
Phone: (202) 783-3238  
HTTP URL: <http://www.fcc.gov>

Employees of U S WEST, Inc. shall contact:

Central Distribution Center (CDC)  
1005 17th St. S-30  
Denver, CO 80202  
Telephone: (303) 896-9446  
Fax: (303) 965-8652

Most QWEST publications are available to employees on the company network (E\*MEDIA). Call 303-965-0707 for further information.

## **7.8 Trademarks**

QWEST®

Registered Trademark of QWEST Communications International  
Inc.

