

CenturyLink QC Technical Publication

Optical Wavelength Service (OWS)

NOTICE

The purpose of this document is to describe CenturyLink Optical Wavelength Service (OWS). Sufficient technical detail is furnished to enable a customer to select options and channel interfaces suitable for their application needs. This document describes the technical features of the offering. It's not the intent of this document to provide ordering information beyond specific, available Network Channel (NC) and Network Channel Interface (NCI) Codes.

CenturyLink reserves the right to revise this document for any reason, including but not limited to, conformity with standards promulgated by various governmental or regulatory agencies; utilization of advances in the state of the technical arts; or to reflect changes in the design of equipment, techniques, or procedures described or referred to herein.

Liability to anyone arising out of use or reliance upon any information set forth herein is expressly disclaimed, and no representation or warranties, expressed or implied, are made with respect to the accuracy or utility of any information set forth herein.

This document is not to be construed as a suggestion to any manufacturer to modify or change any of its products, nor does this publication represent any commitment by CenturyLink to purchase any specific products. Further, conformance to this publication does not constitute a guarantee of a given supplier's equipment and/or its associated documentation.

Ordering and access information for CenturyLink Publications can be obtained from the References Chapter of this document.

If further information is required, please contact:

CenturyLink
700 W Mineral Ave.
Littleton, CO 80120
E-mail: techpub@qwest.com

COMMENTS on PUB 77412

PLEASE TEAR OUT AND SEND YOUR COMMENTS/SUGGESTIONS TO:

CenturyLink
700 W Mineral Ave.
Littleton, CO 80120
E-mail: techpub@qwest.com

Information from you helps us to improve our Publications. Please take a few moments to answer the following questions and return to the above address.

Was this Publication valuable to you in understanding the technical parameters of our service?	YES _____	NO _____
Was the information accurate and up-to-date?	YES _____	NO _____
Was the information easily understood?	YES _____	NO _____
Were the contents logically sequenced?	YES _____	NO _____
Were the tables and figures understandable and helpful	YES _____	NO _____
Were the pages legible?	YES _____	NO _____

If you answered NO to any of the questions and/or if you have any other comments or suggestions, please explain:

(Attach additional sheet, if necessary)

Name _____ Date _____

Company _____

Address _____

Telephone Number _____

E-mail _____

CONTENTS

Chapter and Section	Page
1. Introduction	1-1
1.1 General.....	1-1
1.2 Reason for Reissue	1-1
1.3 Scope	1-1
1.4 Organization of Document.....	1-1
2. Service Description	2-1
2.1 General.....	2-1
2.2 Available Protocols	2-2
2.2.1 Storage Area Network (SAN)	2-2
2.2.2 Ethernet	2-3
2.2.3 Optical Transport Network (OTN).....	2-3
2.2.4 SONET	2-4
2.3 Protocol Channel Requirements	2-5
2.4 Architecture	2-7
3. Network Interfaces	3-1
3.1 Applicability of Technical Specifications.....	3-1
3.2 Available Interfaces	3-1
3.3 Network Interface Power Levels and Distance Limitations	3-11
3.4 NC and NCI Codes	3-21
3.5 NC Code Function and Format.....	3-22
3.6 OWS Network Channel Codes	3-22
3.7 NCI Code Form and Components.....	3-29
3.8 OWS Network Channel Interface Codes.....	3-30
3.9 OWS NC/NCI Code Combinations.....	3-47
4. Performance Specifications.....	4-1
4.1 General.....	4-1
4.2 Service Availability	4-1
4.3 Bit Error Ratio (BER).....	4-2
4.4 Throughput.....	4-2
4.5 Delay (Latency)	4-3
4.6 Reflectance	4-3
4.7 Jitter	4-4
4.8 Protection Switching.....	4-4

CONTENTS (Continued)

Chapter and Section	Page
5. Maintenance.....	5-1
5.1 CenturyLink Responsibilities.....	5-1
5.2 Customer Responsibilities	5-1
6. Definitions.....	6-1
6.1 Acronyms	6-1
6.2 Glossary	6-3
7. References	7-1
7.1 American National Standards Institute Documents.....	7-1
7.2 Telcordia Documents.....	7-2
7.3 IBM Redbooks	7-2
7.4 International Telecommunication Union - Telecommunication Standardization Sector (ITU-T) Recommendations	7-3
7.5 CenturyLink Technical Publications	7-3
7.6 Institute of Electrical and Electronics Engineers Documents	7-4
7.7 International Organization for Standardization/International Electrotechnical Commission Publications	7-4
7.8 Ordering Information.....	7-4
7.9 Trademarks	7-6
 Figures	
2-1 OWS Network Example.....	2-10
3-1 NC and NCI Codes	3-21
3-2 OWS NCI Code Example.....	3-29
 Tables	
3-1 Available SAN Interfaces.....	3-3
3-2 Available Ethernet Interfaces	3-4
3-3 Available OTN Interfaces	3-5
3-4 Available SONET Interfaces.....	3-7
3-5 SAN Power Levels and Maximum Reach	3-12
3-6 Ethernet Power Levels and Maximum Reach.....	3-13
3-7 OTN Power Levels and Maximum Reach.....	3-15
3-8 SONET Power Levels and Maximum Reach	3-17

CONTENTS (Continued)

Tables	Page
3-9 OWS NC Codes for SAN	3-23
3-10 OWS NC Codes for Ethernet.....	3-25
3-11 OWS NC Codes for OTN	3-26
3-12 OWS NC Codes for SONET	3-28
3-13 OWS NCI Codes at Access Carrier and End User Customer Premises for SAN.....	3-31
3-14 OWS NCI Codes at Access Carrier and End User Customer Premises for Ethernet	3-32
3-15 OWS NCI Codes at Access Carrier and End User Customer Premises for OTN.....	3-33
3-16 OWS NCI Codes at Access Carrier and End User Customer Premises for SONET	3-36
3-17 OWS Protocol Channel NCI Codes at CenturyLink COs for SAN.....	3-39
3-18 OWS Protocol Channel NCI Codes at CenturyLink COs for Ethernet	3-40
3-19 OWS Protocol Channel NCI Codes at CenturyLink COs for OTN	3-41
3-20 OWS Protocol Channel NCI Codes at CenturyLink COs for SONET.	3-45
3-21 NC Code, Primary and Secondary NCI Code Combinations for OWS Point-to-Point Protocol Channels for SAN	3-47
3-22 NC Code, Primary and Secondary NCI Code Combinations for OWS Point-to-Point Protocol Channels for Ethernet.....	3-51
3-23 NC Code, Primary and Secondary NCI Code Combinations for OWS Point-to-Point Protocol Channels for OTN.....	3-54
3-24 NC Code, Primary and Secondary NCI Code Combinations for OWS Point-to-Point Protocol Channels for SONET	3-57
4-1 Service Availability	4-2
4-2 Reflectance	4-3

CONTENTS

Chapter and Section	Page
1. Introduction	1-1
1.1 General.....	1-1
1.2 Reason for Reissue	1-1
1.3 Scope	1-1
1.4 Organization of Document.....	1-1

1. Introduction

1.1 General

The purpose of this document is to describe CenturyLink® Optical Wavelength Service f/k/a QWave® (“OWS”). Sufficient technical detail is furnished to enable a customer to select options and channel interfaces suitable for their application needs. This document describes the technical features of the offering. It’s not the intent of this document to provide ordering information beyond specific, available Network Channel (NC) and Network Channel Interface (NCI) Codes.

1.2 Reason for Reissue

To add/update customer-orderable options:

- Add 40 Gigabit Ethernet Service

1.3 Scope

This document describes OWS as offered by CenturyLink to its customers. It covers distinguishing interface features, technical specifications, and defines valid customer Network Interfaces.

1.4 Organization of Document

- | | |
|-----------|---|
| Chapter 1 | Introduction: Provides the purpose, scope and summary of the Publication and its organization. |
| Chapter 2 | Service Description: Describes the features, functions and protocol channel options of OWS. |
| Chapter 3 | Network Interfaces: Details the physical interfaces offered by this service. Also briefly addresses the form and function of Network Channel Codes and Network Channel Interface Codes as they pertain to this service. Also presents the interface configurations available with this service. |
| Chapter 4 | Performance Specifications: Furnishes expectations for service availability, accuracy and throughput. |
| Chapter 5 | Maintenance: Provides the CenturyLink and corresponding customer maintenance responsibilities of the service. |
| Chapter 6 | Definitions: Presents a listing of acronyms and a glossary of terms related to this Publication. |
| Chapter 7 | References: Provides titles and ordering information for applicable standards and documents as referenced in this Publication. |

CONTENTS

Chapter and Section	Page
2. Service Description	2-1
2.1 General.....	2-1
2.2 Available Protocols	2-2
2.2.1 Storage Area Network (SAN)	2-2
2.2.2 Ethernet	2-3
2.2.3 Optical Transport Network (OTN).....	2-3
2.2.4 SONET	2-4
2.3 Protocol Channel Requirements	2-5
2.4 Architecture	2-7
Figures	
2-1 OWS Network Example.....	2-10

2. Service Description

2.1 General

While this document describes Optical Wavelength Service (OWS) as provided by CenturyLink to its customers, other non-standard designs may be considered on an Individual Case Basis (ICB).

OWS is based on CenturyLink's next generation Reconfigurable Optical Add-Drop Multiplexer (ROADM) or Digital Optical Network (aka Digital ROADM) infrastructure network and enables high capacity, multi-protocol connectivity between:

- Customer premises
- A customer premises and CenturyLink Wire Center/Central Office (CO)
- CenturyLink Wire Centers/COs

OWS channels (or circuits) are:

- Stand-alone, i.e. without a dedicated ROADM system or Dense Wavelength Division Multiplexing (DWDM) channel capacity requirement
- Bidirectional (full duplex), point-to-point
- Protocol and bit-rate specific (e.g., Gigabit Ethernet)
- Transparent to CenturyLink at the higher customer protocol layers
- Provisioned for full rate Layer 1 transport

Customer-orderable options include:

- Various Storage Area Network (SAN), Ethernet, Optical Transport Network (OTN) and Synchronous Optical Network (SONET) standard protocols
- Unprotected transport channels with a 2 fiber Network Interface at both ends
- Two unprotected (dual path) channels with CenturyLink-provided diverse (minimally interoffice) ROADM transport and typically used with Customer Provided Equipment (CPE) enabling failover protocols for end-to-end protection.

This configuration will consist of two similar protocol channels each with a 2 fiber customer interface resulting in a 4 fiber Network Interface at both ends of the service. Fiber facility or signal path diversity will be provided within the OWS core network (near-end ROADM equipment to far-end ROADM equipment). Where available, diverse local loop and any interoffice access facilities to the core ROADM network will also be provided though may be optional or waived depending upon location, design and cost parameters.

- Protected transport channels with a 2 fiber Network Interface at both ends

- Open-Ended Protected transport channel with a 2 fiber Network Interface on one end and a dual path channel with a 4 fiber Network Interface (comprised of two individually unprotected channels) on the other end. (Please note: This feature option is limited to client interfaces that can be encapsulated into an OPU2 or OPU2e only).
- SC, FC or LC UPC duplex connectors at premises locations

Customer Network Interfaces are currently available as singlemode fiber only and will (or may) be delivered from CenturyLink-owned ROADM equipment in the CO (serving or other available Wire Center). While singlemode has greater bandwidth and range specifications with reduced attenuation, fiber route distance limitations may apply such as 10 km or 6.2 mi maximum reach for SAN, (FICON® and Fibre Channel) protocols. Where available, customer-orderable 1550 nm interfaces allow for longer reach.

Expected future enhancements include (850 nm) multimode fiber options at customer premises locations. This is provided as general information only and does not construe a commitment by CenturyLink to deliver these capabilities, which are dependent upon technology and other business factors.

2.2 Available Protocols

The following protocols are available for transport over OWS.

2.2.1 Storage Area Network (SAN)

- Fiber or Fibre Connection (FICON): An IBM mainframe channel for interconnecting servers, control units and storage devices such as Directors with a high data transfer rate. FICON can support multiple concurrent operations on a single channel and is based on the Fibre Channel standard (FICON rates are now Grandfathered).

OWS offers FICON optical interfaces at 1.0625 and 2.125 Gbps for providing extended connections to various CPUs or Input/Output (I/O) devices in support of customer FICON Bridge or conversion mode (FCV) as well as the IBM® implementation of FICON Direct Attachment or native mode (FC) channel topologies (FICON rates are now Grandfathered).

Fibre Channel options include:

- FC-100* at 1.0625 Gbps
- FC-200 at 2.125 Gbps
- FC-400 at 4.25 Gbps
- FC-1200 at 10.52 Gbps

* Denotes the effective data transfer rate in MB/s.

2.2.2 Ethernet

- Fast Ethernet at 125 Mbps* (Grandfathered)
- Gigabit Ethernet at 1.25 Gbps
- 10 Gigabit Ethernet WAN PHY at 9.953 Gbps
- 10 Gigabit Ethernet LAN PHY at 10.3125 Gbps
- 40 Gigabit Ethernet at 41.25 Gbps (over 4 WDM lanes)
- 100 Gigabit Ethernet at 103.125 Gbps (over 4 WDM lanes)

* Denotes the line-encoded transmission rate.

OWS supports full duplex, point-to-point Ethernet circuits including the transport of jumbo frames up to 9600 bytes (minimum).

2.2.3 Optical Transport Network (OTN)

- OTU1 at 2.666 Gbps
- OTU2 at 10.709 Gbps
- OTU2e at 11.096 Gbps
- OTU3 at 43.018 Gbps (including over 4 WDM lanes)
- OTU4 at 111.810 Gbps (over 4 WDM lanes)

All OTN (OTUk) bit rates are ± 20 ppm, OTU2e is ± 100 ppm

OWS will provide for transport of customers' ITU-T G.709 Optical channel Transport Unit (OTUk) or G.Sup43 OTU2e signals with support of OTN regeneration over the company ROADM/DWDM network. While the OTUk layer will be terminated as necessary; the Optical channel Data Unit (ODUk) and related overhead with customer-mapped payload(s) and any APS signaling, synchronization information, etc. depending upon embedded protocols and end-to-end application will be transparently transported across the OWS point-to-point OTUk channel.

Customer-Provided Equipment is responsible for ensuring appropriate OTUk frame structure and bit rate compliance in accordance with the ITU-T G.709 and supporting lower OTN physical layer specifications, including transmission of a null pattern for no or standard (default) Forward Error Correction (FEC) containing the Reed-Solomon RS(255,239) codes with 6.2 dB gain. As different equipment may be used to provide this interface, it's recommended that the customer work with CenturyLink to ensure appropriate provisioning.

2.2.4 SONET

- OC-3 at 155.52 Mbps
- OC-12 at 622.08 Mbps
- OC-48 at 2.488 Gbps
- OC-192 at 9.953 Gbps
- OC-768 at 39.813 Gbps is now Grandfathered

Depending upon the ROADM equipment deployed by CenturyLink at ingress, transport of SONET channels with transparent overhead is provided or provisioned across the OWS network. Customer SONET equipment interconnected over a Muxponder or Transponder-based OC-N circuit can communicate over the Section DCC for remote management of far-end CPE, signal 1+1 Linear or BLSR protection switching using the K1/K2 bytes in STS-1 #1, support STS Contiguous Concatenation for transport of super-rate payloads and where available (as provisioned by CenturyLink) Section trace capabilities over the J0 byte, etc.

It should be noted that within a SONET Muxponder for example some of the customer's original Transport (Section/Line) overhead bytes will not be preserved end-to-end whereas the:

- A1/A2 Framing bytes are always terminated and regenerated.
- The B1 Section BIP-8 error monitoring byte is terminated on ingress and recalculated on egress. Since the Section BIP-8 is calculated over all bits of the previous STS-N frame (after scrambling) the B1 byte must be recalculated if Section, Line or Path layer content changes.
- The B2 Line BIP-8 error monitoring byte may be terminated on ingress and recalculated on egress. As the Line BIP-8 is calculated over all bits of the Line overhead and the envelope capacity of the previous STS-1 frame (before scrambling) the B2 byte must be recalculated if Line or Path layer content changes.
- H1, H2 and H3 STS Payload Pointer and Action bytes may be terminated on ingress and generated on egress in order to track the frequency and phase alignment of the customer STS SPEs within the aggregate STS-N envelope capacity. This capability allows for the multiplexing of incoming SONET signals timed via different clocks.
- S1 Synchronization Status (Messages) byte has to be generated on egress if multiplexing is performed on ingress to the OWS ROADM network.

Optical or transparent multiplexing of customer SONET signals may be performed in the Optical Transport Network (OTN) layers as well as via the incoming Section and Line overhead bytes tunneled in and/or non-standard usage of

undefined/unused SONET Transport overhead bytes in a Muxponder aggregate (e.g., internal STS-192) signal. Thus while proprietary SONET overhead may be transported across the OWS ROADM network, the specific transparent bytes within the incoming customer STS-N frame will depend upon the overhead usage, termination and forwarding capabilities of the equipment including different Muxponder and Transponder cards that may be used by CenturyLink to provide the OWS customers' SONET OC-3, OC-12, OC-48, OC-192 and OC-768 channels.

Note the ability for CPE to derive SONET line-timing traceable to a CenturyLink Stratum 1 Primary Reference Source (PRS) is not a feature of OWS. The synchronous timing sources will vary depending upon Muxponder and Transponder cards, application and ROADM network design. While OC-3, OC-12 and OC-48 facilities may be delivered from a SONET Muxponder or transport system configured with BITS timing, other cards such as with CenturyLink Equipment Platform 2 as well as OC-192 and OC-768 circuits may use through timing which provides independent synchronization for each direction of traffic within the ITU-T G.709 specifications for OTN mapping and multiplexing procedures.

2.3 Protocol Channel Requirements

OWS protocol channels and optical interfaces will be delivered from CenturyLink-owned ROADM/DWDM equipment and will conform to the following standards for rate, format and physical interface. Customer equipment is required to generate the appropriate digital optical signal(s) for transmission to CenturyLink for transport over the OWS ROADM network in conjunction with the ordered protocol channel(s).

Storage Area Network (SAN)

FICON refers to the functions and Fibre Channel (FC) upper layer (FC-4) mapping protocols and architecture defined by American National Standards Institute (ANSI) InterNational Committee for Information Technology Standards (INCITS) FC-SB-2 (for single byte FICON) and FC-SB-3 (for FICON Cascading), specifications as used by IBM S/390® and zSeries® hardware and software for Fibre Channel attachment of I/O devices and systems (IBM and non-IBM).

For FICON and Fibre Channel:

- ANSI INCITS 424, *Fibre Channel - Framing and Signaling-2 (FC-FS-2)*, defines the expected frame format and transmission protocol
- ANSI INCITS 404, *American National Standard for Information Technology - Fibre Channel - Physical Interfaces-2 (FC-PI-2)*, specifies the physical layer (FC-0) requirements consisting of transmission media, transmitter devices, receiver devices and their interfaces
- FICON rates are now Grandfathered

Ethernet

- Institute of Electrical and Electronics Engineers, IEEE 802.3-2008, *IEEE Standard for Information technology – Telecommunications and information exchange between systems – Local and metropolitan area networks – Specific requirements – Part 3: Carrier sense multiple access with collision detection (CSMA/CD) access method and physical layer specifications*
- IEEE 802.3ba-2010, *Amendment 4: Media Access Control Parameters, Physical Layers, and Management Parameters for 40 Gb/s and 100 Gb/s Operation*

The customer management agent should set the appropriate bits in the AN advertisement register to advertise the supported end-to-end capabilities including full duplex with auto-negotiation enabled per Clauses 22.2.4.1.4 and 37.2.5.1.3 of IEEE 802.3-2008. In this configuration, the 1000BASE-X auto-negotiation signaling will originate/terminate in the customer's Ethernet devices (which should be locally attached due to operation of the link timer and possible latency impacts) with transparent transport over the CTL OWS network.

Optical Transport Network (OTN)

- Recommendation ITU-T G.709, *Interfaces for the Optical Transport Network (OTN)*
- Recommendation ITU-T G.693, *Optical interfaces for intra-office systems*
- Recommendation ITU-T G.959.1, *Optical transport network physical layer interfaces*
- ITU-T G.Sup43, *Transport of IEEE 10GBASE-R in optical transport networks (OTN)*

SONET

- Telcordia Technologies GR-253-CORE, *Synchronous Optical Network (SONET) Transport Systems: Common Generic Criteria*
- ANSI T1.105.06-2002(R2007), *Telecommunications - Synchronous Optical Network (SONET): Physical Layer Specifications*
- For 40G VSR2000-3R2 compliant OC-768 SR-2 optical interfaces, ITU-T Recommendation G.693, *Optical interfaces for intra-office systems*
- SONET channels interconnecting with CenturyLink Synchronous Service Transport (SST) will conform to requirements in Technical Publication 77346.

See Chapter 7 for ordering information as well as a list of other relevant technical references.

Since the physical characteristics may include a variety of media with associated transmitters and receivers capable of operating at different speeds, specific OWS physical layer requirements at the customer Network Interface including protocol, bit rate, wavelength, fiber type and connector options as well as transmit/receive power

levels, maximum reach from the CenturyLink ROADM equipment and NC/NCI Codes for ordering are listed in Chapter 3.

2.4 Architecture

The OWS network is a high capacity shared infrastructure transport platform based on Wavelength Selective Switch (WSS) technology with multi-degree Reconfigurable Optical Add-Drop Multiplexers (ROADMs) or Digital Nodes (“Digital” ROADMs) and interconnecting fiber optic facilities. The ITU-T G.872, *Architecture of optical transport networks*, OTN model ROADM for QC OWS may be a next generation Dense Wavelength Division Multiplexing (DWDM) system based on a parallel architecture that provides scalable, non-service affecting growth without re-engineering of the network and supports remote dynamic reconfiguration for adding and re-routing channels on a per wavelength basis.

Alternatively, a Digital Optical Network architecture with similar Optical Transmission Section (OTS) and physical media layer but digital structure in the equivalent Optical channel Data Unit (ODU) and Optical channel Transport Unit (OTU) upper layers may be used to provide QC OWS. Digital Nodes provide “digital” access to the optical bandwidth enabling sub-wavelength grooming and network reconfigurability.

For each protocol channel, the OWS network will be used to connect two customer-designated add-drop traffic locations, which may be a premises and/or CenturyLink Central Office (CO). Transponders are used to provision the service and provide wavelength conversion for CenturyLink ROADM/DWDM network transport along with appropriate management and multiplexing of the encapsulated/mapped or digitally wrapped customer protocols. The QC OWS ROADM (or Digital ROADM) network equipment implements 1R or 3R regeneration that along with Optical Line Amplifiers will be provided by the company as needed.

The OWS ROADM network may be configured using point-to-point, ring, and/or mesh topologies in support of various customer-orderable 100 Mbps to 100 Gbps point-to-point unprotected or protected protocol channel arrangements and illustrated in Figure 2-1 with an OWS Network Example. Referring to the diagram:

Dual Path Channels

- An End User with locations at Customer Premises 1 and Customer Premises 2 ordered two unprotected (dual path) OC-192 channels with CenturyLink-provided fiber facility or signal path diversity (and no OWS Automatic Protection Switching).
- The OC-192 protocol channels are provided or provisioned for bidirectional, point-to-point transport with transparent SONET overhead across the OWS ROADM Network.

- Each end of the service (at Customer Premises 1 and Customer Premises 2) consists of two 2 fiber OC-192 interfaces (transmit and receive working as indicated by the arrows) resulting in a 4 fiber Network Interface at the CenturyLink-provided Fiber Distribution Panel (FDP). Collocated Customer Provided Equipment (CPE) to provide the end-to-end protection for the OWS redundant and diverse OC-192 channels may vary and isn't shown.
- CenturyLink Wire Centers (WCs) A, G and D are the access points to the core ROADM network for this customer's two OC-192 circuits and may be the Serving Wire Center (SWC) or another Wire Center as determined by CenturyLink Engineering and Local Network policies.
- As unprotected singlemode fiber Network Interfaces will (or may with the evolution of the service and technology) be delivered via OWS ROADM equipment in the Wire Center, fiber route distance limitations may apply and are listed in Table 3-2. CenturyLink will notify the customer if the requested service cannot be provided due to technical feasibility constraints and provide possible alternative options (if any).
- The dashed lines indicate the signal path route for the two unprotected OC-192 channels; OTU2 encapsulated and DWDM transmitted across the OWS ROADM Network. Local loop fiber route diversity will be provided, where available though end-to-end physical path separation for customer circuits with one or two local loops cannot be guaranteed and will depend upon the customer premises location(s), serving and other available Wire Centers with alternate route facilities.

Specifically, the customer must request the OWS option of two unprotected or dual path channels with diversity and CenturyLink will determine the transport facilities for the two separate protocol channels. Diversity will provide for routing of the two unprotected circuits between ROADM nodes and fiber facilities physically separated by a minimum of 25 feet from the first utility vault outside the customer premises or CenturyLink Wire Center to the last utility vault before the customer premises or CenturyLink Wire Center. Several possible architecture options may then exist including:

1. The ability to provide local loop diversity via 2 different Wire Centers for access to the core ROADM network (WC A and WC G for Customer Premises 1 in Figure 2-1).

2. Only one available Wire Center (WC D) for delivery of the service to Customer Premises 2, with the OWS standard design for customers ordering two unprotected channels with diversity being the circuits will be provisioned on separate Transponders (though in this case installed in the same equipment shelf or Network Element at WC D) and interoffice transport diversity is provided by CenturyLink.
3. Local loop diversity with a common Wire Center for access to the core ROADM network with subsequent interoffice transport diversity.

Where local loop diversity is provided by CenturyLink, equipment located on the customer's premises will have a single cable entrance unless the building owner elects to provide two physically separated cable entrances into the building. If special construction charges are required to build an alternate facility route, CenturyLink will present the customer with the option of having OWS without diversity.

Figure 2-1 OWS Network Example

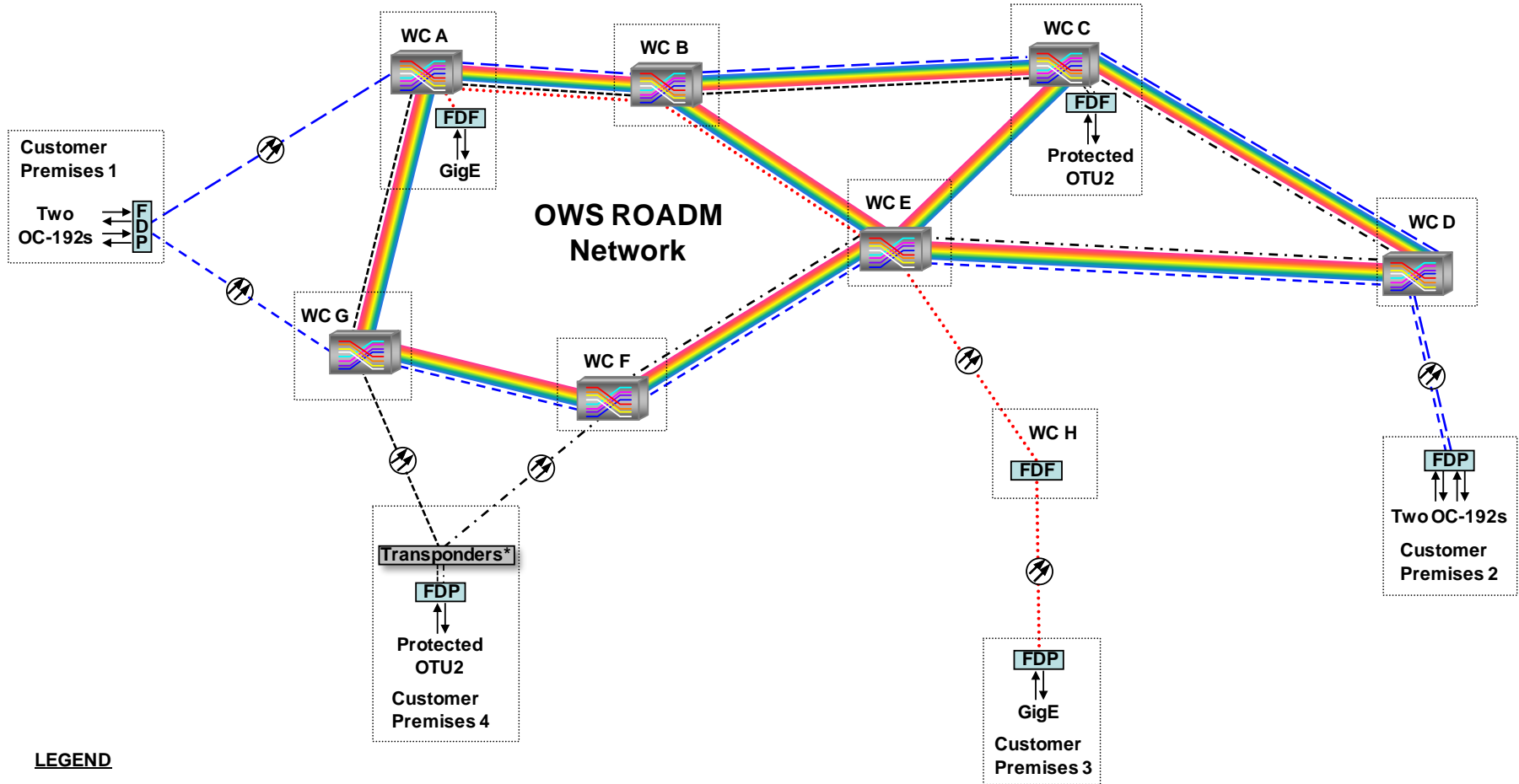

LEGEND

FDF = Fiber Distribution Frame
 FDP = Fiber Distribution Panel
 ROADM = Reconfigurable Optical Add-Drop Multiplexer
 WC = Wire Center
 ⚡ = Fiber Pair

* Not all equipment shown

Unprotected Channels

- Similarly with the example shown for an End User having ordered a single unprotected point-to-point Gigabit Ethernet circuit from their designated location at Customer Premises 3 to CenturyLink Wire Center (WC) A. Though in this case being delivered to the customer from WC H with access to the core ROADM network provided via WC E, which is one (physical) hop away.
- The OWS finished service then terminates on a singlemode Fiber Distribution Frame (FDF) in the CO at WC A and may be cross-connected to another compatible service or (in conjunction with the ordering of) a 2 fiber Optical ITP for interconnection to a collocated Competitive Local Exchange Carrier (CLEC). OWS customer options in the Wire Center may be limited to that identified in the Rates and Services Schedule (RSS) No. 1.

Protected Channels

- A protected point-to-point OTU2 channel is illustrated as having been ordered from a Customer Premises (4) to WC C. While local loop alternate route diversity via 2 different Wire Centers for access to the core ROADM network is shown for the OTU2 working and protect transport signals via WC F and WC G serving Customer Premises 4, several different architecture options are possible and will be as determined by the company.
- As with the previous example of two unprotected (dual path) OC-192 channels, local loop fiber route diversity will be provided where available. Though end-to-end physical path separation for customer circuits with one or two local loops cannot be guaranteed and will depend upon the customer premises location(s), serving and other available Wire Centers with alternate route facilities.
- The ROADM network equipment configuration at Customer Premises 4 as well as WC F and WC G, for example may vary for delivery of OWS protected protocol channels.

Open-Ended Protected Channels

- Lastly, an open-ended protected channel consists of a combination of one protected channel interface on one end (as illustrated in the above Protected Channel scenario from a Customer Premises (4)); and one individually unprotected dual path channel, on the other end (as illustrated in the above Dual Path Channel scenario from a Customer Premises (2)). Please note that this is for illustrative purposes only and this offering is limited to a small subset of interfaces that can be encapsulated into an OPU2 or OPU2e only.

- Local loop fiber route diversity will be provided where available. The end-to-end physical path separation for customer circuits cannot be guaranteed and will depend upon the customer premises location(s), serving and other available Wire Centers with alternate route facilities.
- This option requires joint engineering with compatible customer equipment and provisioning.

CONTENTS

Chapter and Section	Page
3. Network Interfaces	3-1
3.1 Applicability of Technical Specifications.....	3-1
3.2 Available Interfaces	3-1
3.3 Network Interface Power Levels and Distance Limitations	3-11
3.4 NC and NCI Codes	3-21
3.5 NC Code Function and Format.....	3-22
3.6 OWS Network Channel Codes	3-22
3.7 NCI Code Form and Components.....	3-29
3.8 OWS Network Channel Interface Codes.....	3-30
3.9 OWS NC/NCI Code Combinations.....	3-47
Figures	
3-1 NC and NCI Codes	3-21
3-2 OWS NCI Code Example.....	3-29
Tables	
3-1 Available SAN Interfaces.....	3-3
3-2 Available Ethernet Interfaces	3-4
3-3 Available OTN Interfaces	3-5
3-4 Available SONET Interfaces.....	3-7
3-5 SAN Power Levels and Maximum Reach	3-12
3-6 Ethernet Power Levels and Maximum Reach.....	3-13
3-7 OTN Power Levels and Maximum Reach.....	3-15
3-8 SONET Power Levels and Maximum Reach	3-17
3-9 OWS NC Codes for SAN	3-23
3-10 OWS NC Codes for Ethernet.....	3-25
3-11 OWS NC Codes for OTN	3-26
3-12 OWS NC Codes for SONET	3-28
3-13 OWS NCI Codes at Access Carrier and End User Customer Premises for SAN	3-31
3-14 OWS NCI Codes at Access Carrier and End User Customer Premises for Ethernet	3-32
3-15 OWS NCI Codes at Access Carrier and End User Customer Premises for OTN.....	3-33

CONTENTS (Continued)

Tables		Page
3-16	OWS NCI Codes at Access Carrier and End User Customer Premises for SONET	3-36
3-17	OWS Protocol Channel NCI Codes at CenturyLink COs for SAN.....	3-39
3-18	OWS Protocol Channel NCI Codes at CenturyLink COs for Ethernet	3-40
3-19	OWS Protocol Channel NCI Codes at CenturyLink COs for OTN	3-41
3-20	OWS Protocol Channel NCI Codes at CenturyLink COs for SONET.	3-45
3-21	NC Code, Primary and Secondary NCI Code Combinations for OWS Point-to-Point Protocol Channels for SAN	3-47
3-22	NC Code, Primary and Secondary NCI Code Combinations for OWS Point-to-Point Protocol Channels for Ethernet.....	3-51
3-23	NC Code, Primary and Secondary NCI Code Combinations for OWS Point-to-Point Protocol Channels for OTN	3-54
3-24	NC Code, Primary and Secondary NCI Code Combinations for OWS Point-to-Point Protocol Channels for SONET	3-57

3. Network Interfaces

3.1 Applicability of Technical Specifications

Technical specifications presented in this chapter are applicable to Optical Wavelength Service (OWS) only. This document does not attempt to describe the various types of transmission equipment that may be used by CenturyLink to deliver the service.

3.2 Available Interfaces

Note: CenturyLink may provision QC OWS on more than one type of Dense Wavelength Division Multiplexing (DWDM)-based equipment platform, herein referred to generically as Equipment Platform 1, Equipment Platform 2, Equipment Platform 3 and Equipment Platform 4. Due to possible differences with fully integrated technology, some protocols or interfaces may not be available depending upon the specific equipment used by CenturyLink to provide a given customer's QC OWS.

OWS will be provisioned using Reconfigurable Optical Add-Drop Multiplexer (ROADM) or Digital ROADM network equipment and interconnecting fiber facilities. OADM/DWDM-based technology allows CenturyLink to provide standard optical interfaces and transparent transport (see Sections 2.2 and 2.3) for the Storage Area Network (FICON and Fibre Channel), Ethernet, Optical Transport Network (OTN) and SONET protocols listed in Tables 3-1 to 3-4.

As indicated in Chapter 2, OWS protocol channels are available as unprotected or protected and may be ordered either individually with a 2 fiber Network Interface at both ends, or as two unprotected (dual path) channels with CenturyLink-provided (minimally interoffice) transport diversity and a resulting 4 fiber Network Interface at both ends of the service.

OWS protocol channels will be delivered by CenturyLink to the Network Interface (NI), which will be at a Fiber Distribution Panel (FDP) or alternatively Fiber Distribution Frame (FDF) in a Central Office (CO).

The NI for an End User customer installation will be at a connector receptacle or jack on a CenturyLink-provided FDP at the designated premises location.

Carrier Customers have two options at their premises:

- May elect to terminate their own cable on the CenturyLink FDP in the space provided for CenturyLink's transmission equipment
- Have CenturyLink terminate CenturyLink cable on the Carrier's FDP located in the Carrier's workspace

OWS is a fully finished service and as such all Network Interfaces must be located in an accessible, environmentally controlled space. To be accessible, CenturyLink technicians must be able to work and perform tests at the End User or Carrier premises without delay, at any time of day, any day of the year.

OWS Network Interfaces may be equipped with one of the available connector types indicated in Tables 3-1 to 3-4. Fiber optic patchcords or duplex jumper cables to connect the Customer Provided Equipment to the CenturyLink FDP must be provided by the customer and should be at least 3 meters long to facilitate their attachment.

CenturyLink Tech Pub 77368, *CUSTOMER PREMISES ENVIRONMENTAL SPECIFICATIONS AND INSTALLATION GUIDE*, describes the environmental and installation requirements as well as the powering and grounding options for CenturyLink telecommunications equipment placed on customer premises.

CenturyLink Tech Pub 77419, *SPECIFICATIONS FOR THE PLACEMENT OF QWEST EQUIPMENT IN CUSTOMER-OWNED OUTDOOR CABINETS*, describes the environmental (including electromagnetic compatibility), power, and grounding requirements for customer-owned outdoor cabinets (if provided) in order to allow the placement of CenturyLink-owned equipment inside these cabinets for the provisioning of OWS to the customer.

Table 3-1 Available SAN Interfaces

Protocol	Bit Rate	Central Wavelength	Fiber Type	Connector	Equipment Platform 1	Equipment Platform 2	Equipment Platform ¹⁰		Equipment Platform 4	
							3A	3B		
Storage Area Network (SAN)										
FICON	1.0625 Gbps	1310 nm	SM	Duplex SC, FC or LC UPC	GF ⁹	GF ⁹	GF ⁹	Not Available	Not Available	
		1550 nm	SM		GF ⁹	GF ⁹	GF ⁹	Not Available	Not Available	
	2.125 Gbps	1310 nm	SM	Duplex SC, FC or LC UPC	GF ⁹	GF ⁹	GF ⁹	Not Available	Not Available	
		1550 nm	SM		GF ⁹	GF ⁹	GF ⁹	Not Available	Not Available	
Fibre Channel	FC-100	1310 nm	SM	Duplex SC, FC or LC UPC	Available	Available (unprotected only)	Available	Not Available	Not Available	
		1550 nm	SM		Available	Available (unprotected only)	Available	Not Available	Not Available	
	FC-200	1310 nm	SM	Duplex SC, FC or LC UPC	Available	Available (unprotected only)	Available	Not Available	Not Available	
		1550 nm	SM		Available	Available (unprotected only)	Available	Not Available	Not Available	
	FC-400	4.25 Gbps	1310 nm	SM	Duplex SC, FC or LC UPC	Available	Available (unprotected only)	Available	Not Available	Not Available
	FC-1200	10.52 Gbps	1310 nm	SM	Duplex SC, FC or LC UPC	Available	Available	Available	Not Available	Available

Table 3-2 Available Ethernet Interfaces

Protocol		Bit Rate	Central Wavelength	Fiber Type	Connector	Equipment Platform 1	Equipment Platform 2	Equipment Platform ¹⁰		Equipment Platform 4
								3A	3B	
Ethernet										
Fast Ethernet	100BASE-LX10	125 Mbps	1310 nm	SM	Duplex SC, FC or LC UPC	GF ⁹	Not Available	GF ⁹	Not Available	Not Available
Gigabit Ethernet	1000BASE-LX, or 1000BASE-LX10	1.25 Gbps	1310 nm	SM	Duplex SC, FC or LC UPC	Available	Available	Available	Available	Available
	1000BASE-ZX		1550 nm	SM		Available	Available	Available	Available	Available
10G WAN PHY	10GBASE-LW	9.953 Gbps	1310 nm	SM	Duplex SC, FC or LC UPC	Available	Available	Available	Available	Available
	10GBASE-EW, or 10GBASE-ZW		1550 nm	SM		Available	Available	Available	Available	Available
10G LAN PHY	10GBASE-LR	10.3125 Gbps	1310 nm	SM	Duplex SC, FC or LC UPC	Available	Available	Available	Available	Available
	10GBASE-ER, or 10GBASE-ZR		1550 nm	SM		Available	Available	Available	Available	Available

Table 3-2 Available Ethernet Interfaces (Continued)

Protocol		Bit Rate	Central Wavelength	Fiber Type	Connector	Equipment Platform 1	Equipment Platform 2	Equipment Platform ¹⁰		Equipment Platform 4
								3A	3B	
Ethernet										
40 Gigabit Ethernet	40GBASE-LR4	41.25 Gbps	1271 nm 1291 nm 1311 nm 1331 nm	SM	Duplex LC UPC	Available (unprotected only)	Not Available	Not Available	Available	Available
100 Gigabit Ethernet	100GBASE-LR4	103.125 Gbps	1295.56 nm 1300.05 nm 1304.58 nm 1309.14 nm	SM	Duplex SC, FC or LC UPC ²	Available	Available (unprotected only)	Available	Available	Available

Table 3-3 Available OTN Interfaces

Protocol		Bit Rate	Central Wavelength	Fiber Type	Connector	Equipment Platform 1	Equipment Platform 2	Equipment Platform ¹⁰		Equipment Platform 4
								3A	3B	
Optical Transport Network (OTN)										
OTU1	P1L1-1D1/ IR-1	2.666 Gbps	1310 nm	SM	Duplex SC, FC or LC UPC	Available	Available	Available	Available	Available
	P1L1-1D2/ LR-2		1550 nm			Available	Available	Available	Available	Available
OTU2	VSR2000- 2R1	10.709 Gbps	1310 nm	SM	Duplex SC, FC or LC UPC	Available	Available	Available	Available	Available
	P1S1- 2D2b/ P1L1-2D2		1550 nm	SM		Available	Available	Available	Available	Available
OTU2e	VSR2000- 2R1	11.096 Gbps	1310 nm	SM	Duplex SC, FC or LC UPC	Available	Available	Available	Available	Available
	P1S1- 2D2b/ P1L1-2D2		1550 nm	SM		Available	Available	Available	Available	Available

Table 3-3 Available OTN Interfaces (Continued)

Protocol	Bit Rate	Central Wavelength	Fiber Type	Connector	Equipment Platform 1	Equipment Platform 2	Equipment Platform ¹⁰		Equipment Platform 4	
							3A	3B		
Optical Transport Network (OTN)										
OTU3	P1T1-3D1	43.018 Gbps	1271 nm 1291 nm 1311 nm 1331 nm	SM	Duplex SC, FC or LC UPC	Available	Not Available	Not Available	Not Available	Available
	40GBASE-FR/ VSR2000-3R2		1550 nm							
OTU4	100GBAS E-LR4	111.810 Gbps	1295.56 nm 1300.05 nm 1304.58 nm 1309.14 nm	SM	Duplex SC, FC or LC UPC	Available	Not Available	Available (unprotected only)	Available	Available

Table 3-4 Available SONET Interfaces

Protocol	Bit Rate	Central Wavelength	Fiber Type	Connector	Equipment Platform 1	Equipment Platform 2	Equipment Platform ¹⁰		Equipment Platform 4	
							3A	3B		
SONET										
OC-3	IR-1	155.52 Mbps	1310 nm	SM	Duplex SC, FC or LC UPC	Available (unprotected only)	Available (unprotected only)	Available (unprotected only)	Available (unprotected only)	Available (unprotected only)
	LR-1		1310 nm	SM		Available (unprotected only)	Not Available	Available (unprotected only)	Available (unprotected only)	Available (unprotected only)
	LR-2		1550 nm	SM		Available (unprotected only)	Available (unprotected only)	Available (unprotected only)	Available (unprotected only)	Available (unprotected only)
OC-12	IR-1	622.08 Mbps	1310 nm	SM	Duplex SC, FC or LC UPC	Available (unprotected only)	Available (unprotected only)	Available (unprotected only)	Available (unprotected only)	Available (unprotected only)
	LR-1		1310 nm	SM		Available (unprotected only)	Not Available	Available (unprotected only)	Available (unprotected only)	Available (unprotected only)
	LR-2		1550 nm	SM		Available (unprotected only)	Available (unprotected only)	Available (unprotected only)	Available (unprotected only)	Available (unprotected only)

Table 3-4 Available SONET Interfaces (Continued)

Protocol		Bit Rate	Central Wavelength	Fiber Type	Connector	Equipment Platform 1	Equipment Platform 2	Equipment Platform ¹⁰		Equipment Platform 4
								3A	3B	
SONET										
OC-48	IR-1	2.488 Gbps	1310 nm	SM	Duplex SC, FC or LC UPC	Available	Available	Available	Available	Available
	LR-1		1310 nm	SM		Available	Not Available	Available	Available	Available
	LR-2		1550 nm	SM		Available	Available	Available	Available	Available
OC-192	SR-1	9.953 Gbps	1310 nm	SM	Duplex SC, FC or LC UPC	Available	Available	Available	Available	Available
	IR-2		1550 nm	SM		Available	Available	Available	Available	Available
OC-768	SR-2	39.813 Gbps	1550 nm	SM	Duplex SC, FC or LC UPC	GF ⁹	GF ⁹	GF ⁹	Not Available	GF ⁹

Tables 3-1 to 3-4 Notes:

1. SM (Singlemode) fiber is 9-10/125 μm and shall meet the requirements in GR-20-CORE, *Generic Requirements for Optical Fiber and Optical Fiber Cable* and ITU-T Recommendation G.652, *Characteristics of a single-mode optical fibre and cable*.
2. SC/UPC (with Ultra Physical Contact polish) is the CenturyLink default optical connector for new OWS Network Interfaces whereas FC and LC are customer-specified options, where available at premises locations only. As there are no (e.g., NCI) codes for ordering, the customer should make the request to their Sales or Account Team, or the connector type would be determined during the field visit and captured on the site survey form.
3. SC (Subscriber Connector) is a push-pull type of fiber optic connector with a square barrel; standardized in ANSI/TIA/EIA-604-3-B, *FOCIS (Fiber Optic Connector Intermateability Standard) 3, Type SC and SC-APC* and equivalent IEC 61754-4, *Fibre Optic Connector Interfaces - Part 4: Type SC Connector Family*.
4. FC (Fiber Connector) is a keyed, locking type of fiber optic connector with a round barrel and threaded retaining ring; standardized in ANSI/TIA/EIA-604-4-B, *FOCIS (Fiber Optic Connector Intermateability Standard) 4, Type FC and FC-APC* and equivalent IEC 61754-13, *Fibre Optic Connector Interfaces - Part 13: Type FC-PC Connector*.
5. LC (Lucent or Local Connector) is a small form-factor fiber optic connector with a cylindrical ferrule and split sleeve coupler; standardized in ANSI/TIA/EIA-604-10-A, *FOCIS (Fiber Optic Connector Intermateability Standard) 10, Type LC* and equivalent IEC 61754-20, *Fibre Optic Connector Interfaces - Part 20: Type LC Connector Family*.
6. OWS Network Interfaces shall meet the optical, mechanical and environmental performance requirements of ISO/IEC 11801: 2002+A1:2008, *Information technology - Generic cabling for customer premises*.
7. Bit rates listed may not correspond to effective channel data rate in a given application due to protocol overheads and other factors.
8. All interfaces will be delivered from CenturyLink-owned equipment.
9. GF (Grandfathered) services will continue to be supported on existing contracts (this provision includes the Federal Network contract) until the platform supporting that service has reached end of life or the current contract expires. No new orders or renewals will be accepted.
10. Where both 3A and 3B show "available", the platforms are considered interoperable/interchangeable for either end of the circuit within that code description.

3.3 Network Interface Power Levels and Distance Limitations

Tables 3-5 to 3-8 list the acceptable range of Transmit (Tx) and Receive (Rx) optical power levels at the NI for the various OWS protocol channels. See the notes immediately following the table for important information concerning the interface specifications.

The maximum supported cable reach or fiber route distance from the CenturyLink-provided ROADM/DWDM equipment to the customer's active equipment shall be as listed in Tables 3-5 to 3-8 whereas operating distances are based on a variety of worst-case specifications including:

- Fiber properties regarding attenuation, core diameter, bandwidth length product and chromatic dispersion
- Laser properties regarding launch power, spectral characteristics, jitter and rise/fall times
- Receiver properties regarding sensitivity, cutoff frequency and jitter tolerance
- Link properties regarding connection loss and unallocated link margin

Table 3-5 SAN Power Levels and Maximum Reach¹

Protocol Channel		Central Wavelength	Fiber Type	Protection ²	Power Level (dBm) ³				Maximum Reach ⁶
					Tx ⁴		Rx ⁵		
					Min	Max	Min	Max	
Storage Area Network (SAN)									
FICON at 1.0625 Gbps (Grandfathered ²³)		1310 nm	Singlemode	Unprotected	-11.5	1.0	-17.0	-7.0	10 km
				Protected	-11.5	1.0	-17.0	-7.0	10 km
		1550 nm	Singlemode	Unprotected	-4.0	3.0	-19.0	-7.0	38 km ⁷
				Protected	-4.0	3.0	-19.0	-7.0	38 km ⁷
FICON Express at 2.125 Gbps (Grandfathered ²³)		1310 nm	Singlemode	Unprotected	-11.5	1.0	-17.0	-7.0	10 km
				Protected	-11.5	1.0	-17.0	-7.0	10 km
		1550 nm	Singlemode	Unprotected	-4.0	1.0	-26.0	-7.0	48 km ⁷
				Protected	-4.0	1.0	-26.0	-7.0	48 km ⁷
Fibre Channel at 1.0625 Gbps		1310 nm	Singlemode	Unprotected	-11.5	1.0	-17.0	-7.0	10 km
				Protected	-11.5	1.0	-17.0	-7.0	10 km
		1550 nm	Singlemode	Unprotected	-7.0	3.0	-16.0	-7.0	22 km ⁷
				Protected	-4.0	3.0	-19.0	-7.0	38 km ⁷
Fibre Channel at 2.125 Gbps		1310 nm	Singlemode	Unprotected	-11.5	1.0	-16.0	-7.0	10 km
				Protected	-11.5	1.0	-17.0	-7.0	10 km
		1550 nm	Singlemode	Unprotected	-7.0	1.0	-16.0	-7.0	22 km ⁷
				Protected	-4.0	1.0	-26.0	-7.0	48 km ⁷
Fibre Channel at 4.25 Gbps		1310 nm	Singlemode	Unprotected	-10.4	-5.0	-15.3	-1.0	10 km
				Protected	-10.4	-5.0	-15.3	-1.0	10 km
Fibre Channel at 10.52 Gbps		1310 nm Tx 1270-1580 nm Rx ⁹	Singlemode	Unprotected	-8.0	-3.0	-9.0	1.0	8 km ¹⁰
		1310 nm Tx 1270-1600 nm Rx ⁹		Protected	-10.0 ¹¹	-5.0 ¹¹	-7.0 ¹¹	5.0 ¹¹	30 m

Table 3-6 Ethernet Power Levels and Maximum Reach¹

Protocol Channel	Central Wavelength	Fiber Type	Protection ²	Power Level (dBm) ³				Maximum Reach ⁶	
				Tx ⁴		Rx ⁵			
				Min	Max	Min	Max		
Ethernet									
Fast Ethernet (Grandfathered ²³)	100BASE-LX10 ¹²	1310 nm	Singlemode	Unprotected	-11.5	1.0	-17.0	-7.0	10 km
				Protected	-11.5	1.0	-17.0	-7.0	10 km
Gigabit Ethernet	1000BASE-LX, or 1000BASE-LX10	1310 nm	Singlemode	Unprotected	-11.5	1.0	-17.0	-7.0	5/10 km ¹³
				Protected	-11.5	1.0	-17.0	-7.0	5/10 km ¹³
	1000BASE-ZX	1550 nm	Singlemode	Unprotected	-7.0	3.0	-16.0	-7.0	31 km ¹⁴
				Protected	-4.0	3.0	-19.0	-7.0	54 km ¹⁴
10G WAN PHY	10GBASE-LW	1310 nm Tx 1270-1580 nm Rx ⁹	Singlemode	Unprotected	-8.0	-3.0	-9.0	1.0	8 km ¹⁰
				Protected	-10.0 ¹¹	-5.0 ¹¹	-7.0 ¹¹	5.0 ¹¹	30 m
	10GBASE-EW/ 10GBASE-ZW	1550 nm Tx 1270-1580 nm Rx ⁹	Singlemode	Unprotected	-3.0/ -2.0	0.0/ 2.0	-12.0/ -22.0	1.0/ -5.0	31/63 km ¹⁴
				Protected	-7.0/ -6.0	-4.0/ -2.0	-8.0/ -18.0	5.0/ -1.0	20/51 km ¹⁴
10G LAN PHY	10GBASE-LR	1310 nm Tx 1270-1580 nm Rx ⁹	Singlemode	Unprotected	-8.0	-3.0	-9.0	1.0	8 km ¹⁰
				Protected	-10.0 ¹¹	-5.0 ¹¹	-7.0 ¹¹	5.0 ¹¹	30 m
	10GBASE-ER/ 10GBASE-ZR	1550 nm Tx 1270-1580 nm Rx ⁹	Singlemode	Unprotected	-3.0/ -2.0	0.0/ 2.0	-12.0/ -22.0	1.0/ -5.0	31/63 km ¹⁴
				Protected	-7.0/ -6.0	-4.0/ -2.0	-8.0/ -18.0	5.0/ -1.0	20/51 km ¹⁴

Table 3-6 Ethernet Power Levels and Maximum Reach¹ (Continued)

Protocol Channel	Central Wavelength	Fiber Type	Protection ²	Power Level (dBm) ³				Maximum Reach ⁶	
				Tx ⁴		Rx ⁵			
				Min	Max	Min	Max		
Ethernet									
40 Gigabit Ethernet	40GBASE-LR4	1271 nm 1291 nm 1311 nm 1331 nm	Singlemode	Unprotected	-7	2.3	-13.7	2.3	10 km
				Protected	-7	2.3	-13.7	2.3	10 km
100 Gigabit Ethernet	100GBASE-LR4	1295.56 nm 1300.05 nm 1304.58 nm 1309.14 nm	Singlemode	Unprotected	2.0	8.5	-3.0	12.5	10 km
				Protected	-2.0	4.5	1.0	16.5	7 km ¹⁵

Table 3-7 OTN Power Levels and Maximum Reach¹

Protocol Channel		Central Wavelength	Fiber Type	Protection ²	Power Level (dBm) ³				Maximum Reach ⁶
					Tx ⁴		Rx ⁵		
					Min	Max	Min	Max	
Optical Transport Network (OTN)									
OTU1	P1L1-1D1 ¹⁶ / IR-1	1310 nm	Singlemode	Unprotected	-7.0	-2.0	-17.0	2.0	30 km ¹⁰
				Protected	-11.0	-6.0	-13.0	6.0	20 km ¹⁰
	P1L1-1D2 ¹⁶ / LR-2	1550 nm	Singlemode	Unprotected	-4.0	1.0	-26.0	-7.0	69 km ¹⁴
				Protected	-8.0	-3.0	-22.0	-3.0	57 km ¹⁴
OTU2	VSR2000-2R1 ¹⁷	1310 nm Tx 1270-1580 nm Rx ⁹	Singlemode	Unprotected	-8.0	-3.0	-9.0	1.0	8 km ¹⁰
		1310 nm Tx 1270-1600 nm Rx ⁹		Protected	-10.0 ¹¹	-5.0 ¹¹	-7.0 ¹¹	5.0 ¹¹	30 m
	P1S1-2D2b/ P1L1-2D2 ¹⁶	1550 nm Tx 1270-1580 nm Rx ⁹	Singlemode	Unprotected	-3.0/ -2.0	0.0/ 2.0	-12.0/ -22.0	1.0/ -5.0	31/63 km ¹⁴
		1550 nm Tx 1270-1600 nm Rx ⁹		Protected	-7.0/ -6.0	-4.0/ -2.0	-8.0/ -18.0	5.0/ -1.0	20/51 km ¹⁴

Table 3-7 OTN Power Levels and Maximum Reach¹ (Continued)

Protocol Channel	Central Wavelength	Fiber Type	Protection ²	Power Level (dBm) ³				Maximum Reach ⁶	
				Tx ⁴		Rx ⁵			
				Min	Max	Min	Max		
Optical Transport Network (OTN)									
OTU2e	VSR2000-2R1 ¹⁷	1310 nm Tx 1270-1580 nm Rx ⁹	Singlemode	Unprotected	-8.0	-3.0	-9.0	1.0	8 km ¹⁰
		1310 nm Tx 1270-1600 nm Rx ⁹		Protected	-10.0 ¹¹	-5.0 ¹¹	-7.0 ¹¹	5.0 ¹¹	30 m
	P1S1-2D2b/ P1L1-2D2 ¹⁶	1550 nm Tx 1270-1580 nm Rx ⁹	Singlemode	Unprotected	-3.0/ -2.0	0.0/ 2.0	-12.0/ -22.0	1.0/ -5.0	31/63 km ¹⁴
		1550 nm Tx 1270-1600 nm Rx ⁹		Protected	-7.0/ -6.0	-4.0/ -2.0	-8.0/ -18.0	5.0/ -1.0	20/51 km ¹⁴
OTU3	40GBASE-LR4 ¹⁸	1271 nm	Singlemode	Unprotected	-	6.3	See Note 19		10 km
		1291 nm		Protected	-	2.3	See Note 19		
	40GBASE-FR/ VSR2000-3R2 ¹⁷	1550 nm	Singlemode	Unprotected	-2.0	1.0	-4.0	5.0	15 km ²⁰
				Protected	-4.0 ¹¹	-1.0 ¹¹	-2.0 ¹¹	7.0 ¹¹	30 m
OTU4	100GBASE-LR4 ¹⁸	1295.56 nm	Singlemode	Unprotected	2.0	8.5	-3.0	12.5	10 km
		1300.05 nm 1304.58 nm 1309.14 nm		Protected	-2.0	4.5	1.0	16.5	7 km ¹⁵

Table 3-8 SONET Power Levels and Maximum Reach¹

Protocol Channel		Central Wavelength	Fiber Type	Protection ²	Power Level (dBm) ³				Maximum Reach ⁶
					Tx ⁴		Rx ⁵		
					Min	Max	Min	Max	
SONET									
OC-3	IR-1	1310 nm	Singlemode	Unprotected	-17.0	-2.0	-17.0	-6.0	21 km
	IR-1	1310 nm	Singlemode	Protected	-17.0	-2.0	-17.0	-6.0	21 km
	LR-1	1310 nm	Singlemode	Unprotected	-4.0	1.0	-25.0	-7.0	45 km ²¹
	LR-1	1310 nm	Singlemode	Protected	-4.0	1.0	-25.0	-7.0	45 km ²¹
	LR-2	1550 nm	Singlemode	Unprotected	-4.0	1.0	-26.0	-7.0	95 km ²²
	LR-2	1550 nm	Singlemode	Protected	-4.0	1.0	-26.0	-7.0	95 km ²²
OC-12	IR-1	1310 nm	Singlemode	Unprotected	-17.0	-2.0	-17.0	-6.0	21 km
	IR-1	1310 nm	Singlemode	Protected	-17.0	-2.0	-17.0	-6.0	21 km
	LR-1	1310 nm	Singlemode	Unprotected	-5.0	1.0	-25.0	-7.0	42 km
	LR-1	1310 nm	Singlemode	Protected	-5.0	1.0	-25.0	-7.0	42 km
	LR-2	1550 nm	Singlemode	Unprotected	-4.0	1.0	-26.0	-7.0	85 km
	LR-2	1550 nm	Singlemode	Protected	-4.0	1.0	-26.0	-7.0	85 km
OC-48	IR-1	1310 nm	Singlemode	Unprotected	-7.0	-2.0	-16.0	2.0	21 km
				Protected	-7.0	-2.0	-17.0	2.0	21 km
	LR-1	1310 nm	Singlemode	Unprotected	-4.0	1.0	-25.0	-7.0	42 km
				Protected	-4.0	1.0	-25.0	-7.0	42 km
	LR-2	1550 nm	Singlemode	Unprotected	-4.0	1.0	-26.0	-7.0	60 - 85 km
Protected				-4.0	1.0	-26.0	-7.0	60 - 85 km	

Table 3-8 SONET Power Levels and Maximum Reach¹ (Continued)

Protocol Channel	Central Wavelength	Fiber Type	Protection ²	Power Level (dBm) ³				Maximum Reach ⁶	
				Tx ⁴		Rx ⁵			
				Min	Max	Min	Max		
SONET									
OC-192	SR-1	1310 nm Tx 1270-1580 nm Rx ⁹	Singlemode	Unprotected	-8.0	-3.0	-9.0	1.0	2 - 7 km
		1310 nm Tx 1270-1600 nm Rx ⁹		Protected	-10.0 ¹¹	-5.0 ¹¹	-7.0 ¹¹	5.0 ¹¹	30 m
	IR-2	1550 nm Tx 1270-1580 nm Rx ⁹	Singlemode	Unprotected	-3.0	0.0	-12.0	1.0	40 km
		1550 nm Tx 1270-1600 nm Rx ⁹		Protected	-7.0	-4.0	-8.0	5.0	33 km ²²
OC-768 Grandfathered ²²	SR-2	1550 nm Tx 1290-1565 nm Rx ⁹	Singlemode	Unprotected	-2.0	1.0	-4.0	5.0	2 km
		1550 nm Tx 1270-1600 nm Rx ⁹		Protected	-6.0	-3.0	0.0	9.0	2 km

Tables 3-5 to 3-8 Notes:

1. These protocol channel power levels and maximum reach values support multiple Equipment Platforms, Network Interface cards, Small Form-factor Pluggable (SFP) and 10 Gigabit Small Form-factor Pluggable (XFP) hot-swappable, protocol-independent optical transceiver modules and should be used as a customer planning guide. Other values may be possible including further reach in some cases depending upon the characteristics of the protocol, fiber quality and transceiver specifications. The customer should work jointly with CenturyLink to ensure that power level requirements are appropriately met in order to guarantee error-free steady state channel performance and where necessary, optical attenuators must be provided by the customer.
2. Unprotected means there is no CenturyLink-provided Automatic Protection Switching. As described in Chapter 2, OWS customers have the option of ordering two unprotected protocol channels with CenturyLink assigned transport diversity on the ROADM network and providing their own equipment or failover protocols for protection.
3. All power levels are based on a valid test pattern at the customer Network Interface and include a maximum 2 dB allocation for CenturyLink singlemode fiber jumpers, connectors and splice loss.
4. Tx represents the Transmit direction from CenturyLink to the customer.
5. Rx represents the Receive direction from the customer to CenturyLink.

Tables 3-5 to 3-8 Notes (Continued):

6. Maximum reach is the singlemode fiber route distance from CenturyLink active (ROADM) equipment to customer active equipment and may be optical power, chromatic or Polarization Mode Dispersion (PMD) limited especially with higher bit rate links or usage of standard singlemode dispersion-unshifted (i.e., conventional) fiber in the 1550 nm region. In no case will a further distance be supported than that published in the applicable protocol and/or fiber optic standard unless explicitly agreed to by CenturyLink and the customer with an understanding of any potential performance impacts.
7. The distance is estimated using the assumption of 0.5 dB/km maximum attenuation for 1550 nm singlemode fiber outdoor cable and an allocation of 2 dB total connection and splice loss according to ANSI INCITS 352.
8. These Fibre Channel interfaces do not include Open Fibre Control (OFC).
9. Acceptable CenturyLink receive wavelength range
10. The distance is estimated using the assumption of 0.4 dB/km installed fiber loss for the 1310 nm link and 2 dB total connection and splice loss according to ITU-T G.652 or IEEE 802.3-2008 with G.652.B fiber type. Similarly per ANSI INCITS 364, the longwave specification for 10G FC is based on the 10G LAN PHY optical specification for 10GBASE-LR links.
11. Excluding cable, connectors and splice loss
12. 100BASE-LX10 is a newer IEEE 802.3-2008 physical layer specification for a 100 Mb/s point-to-point link over two singlemode optical fibers up to at least 10 km and corresponds with the definition change of 100BASE-FX from two optical fibers to two multimode optical fibers, thus this protocol may be referred to as 100BASE-FX over singlemode fiber in some equipment documentation.
13. 10 km is Network Interface Card dependent whereas 1000BASE-LX10 must be supported by customer equipment.
14. The distance is estimated using the assumption of 0.35 dB/km installed fiber loss and 2 dB total connection and splice loss according to ITU-T G.652 or IEEE 802.3-2008 with G.652.B fiber type for 1550 nm links (note that extended reach 1000BASE-ZX, 10GBASE-ZW and 10GBASE-ZR are considered non-standard).
15. The distance is estimated using the assumption of 0.43 dB/km installed fiber loss for the 1310 nm nominal wavelength link and 2 dB total connection and splice loss according to IEEE 802.3ba-2010 and ITU-T G.695.
16. Per ITU-T G.959.1
17. Per ITU-T G.693
18. Physical layer specifications for multi-lane OTU3 and OTU4 interfaces are being added to ITU-T G.695 and G.959.1, including those corresponding to the use of the optical modules developed for IEEE 40GBASE-R and 100GBASE-R signals.
19. The link characteristics are similar to that published for 40GBASE-LR4 in Clause 87 of IEEE 802.3ba-2010 and will require joint engineering / test & turn-up to ensure the appropriate power levels.
20. The distance is estimated using the assumption of 0.275 dB/km installed fiber loss for the 1550 nm link and 2 dB total connection and splice loss according to ITU-T G.695.

Tables 3-5 to 3-8 Notes (Continued):

21. The distance is estimated using the assumption of 0.55 dB/km installed fiber loss including splices and connectors for 1310 nm links according to GR-253-CORE.
22. The distance is estimated using the assumption of 0.275 dB/km installed fiber loss including splices and connectors for 1550 nm links according to GR-253-CORE.
23. Grandfathered services will continue to be supported on existing contracts (this provision includes the Federal Network contract) until the platform supporting that service has reached end of life or the current contract expires. No new orders or renewals will be accepted.

3.4 NC and NCI Codes

Note: CenturyLink may provision QC OWS on more than one type of DWDM-based equipment platform, herein referred to generically as Equipment Platform 1, Equipment Platform 2, Equipment Platform 3 and Equipment Platform 4. Due to inherent differences in technology and current positioning of the service, some NC and NCI Codes will be different or Not Applicable (or specifically Not Available in some cases) depending upon the specific equipment used by CenturyLink to provide a given customer's QC OWS. The customer will need to identify their service requirements and work with CenturyLink to determine the appropriate NC/NCIs.

Network Channel (NC) and Network Channel Interface (NCI) Codes convey service and technical parameters. The following sections explain the codes in a general manner and also provide specific codes for ordering OWS. The NC and NCI Codes are provided by the customer to the CenturyLink Service Representative at the time a request for service is initiated. Figure 3-1 shows where the codes apply.

Figure 3-1 NC and NCI Codes

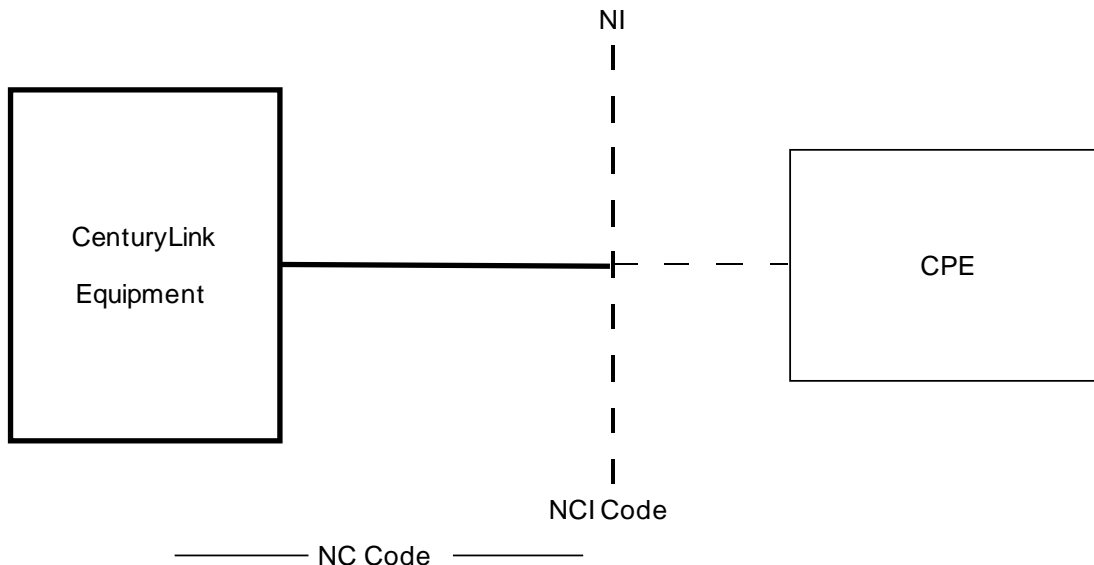

LEGEND

CPE = Customer Provided Equipment
NC = Network Channel
NCI = Network Channel Interface
NI = Network Interface

Additional information concerning NC/NCI Codes is available in ANSI T1.223-2004, *Structure and Representation of Network Channel (NC) and Network Channel Interface (NCI) Codes for information exchanges*. See Chapter 7 for ordering information.

In some instances CenturyLink offerings differ from those described by Telcordia Technologies in their published Industry Support Interface: SR-307, *COMMON LANGUAGE NC/NCI Dictionary*. Furthermore, definitions of NC and NCIs evolve. Therefore, it's important to request CenturyLink OWS as defined in this Technical Publication.

3.5 NC Code Function and Format

Primarily, service considerations are encoded into Network Channel (NC) Codes. Included in this code set are customer options associated with the individual channel services. The NC Code is specified by the customer to advise CenturyLink of the required service connection of the channel.

An NC Code consists of four alpha/numeric characters, which may include a dash (-). There are neither spaces nor delimiters between the characters. The NC Code consists of two data elements:

- The first two characters are the Channel Code, which describes the channel service in an abbreviated form.
- The last two characters are the Optional Feature Code, which represents the option codes available for each Channel Code. Varying combinations of this code allow for further identification of the type of service.

The customer must specify NC Codes for the desired service when ordering OWS.

3.6 OWS Network Channel Codes

Tables 3-9 to 3-12 list the Network Channel (NC) Codes available with CenturyLink OWS. Note that protocol channels are ordered individually or in pairs but are stand-alone without a dedicated ROADM system or DWDM channel capacity requirement.

Table 3-9 OWS NC Codes for SAN

NC Code	Description	Equipment Platform 1	Equipment Platform 2	Equipment Platform		Equipment Platform 4
				3A	3B	
Storage Area Network (SAN) Protocol Channels						
OPD-	LAN, Optical Data Transport, Point-To-Point FICON at 1.0625 Gbps	Not Applicable	Grandfathered	Not Applicable	Not Applicable	Not Applicable
OPDH	LAN, Optical Data Transport, Point-To-Point FICON at 1.0625 Gbps, Rate-adjustable via SONET transport at STS-1-19v, 919.296 Mbps Nominal Payload Rate	√	Not Applicable	√	Not Applicable	Not Applicable
OPDA	LAN, Optical Data Transport, Point-To-Point FICON at 1.0625 Gbps, Protected, Rate-Adjustable via SONET transport at STS-1-19v, 919.296 Mbps Nominal Payload Rate	√	Not Applicable	Not Applicable	Not Applicable	Not Applicable
OPE-	LAN, Optical Data Transport, Point-To-Point FICON at 2.125 Gbps	Not Applicable	Grandfathered	Not Applicable	Not Applicable	Not Applicable
OPEH	LAN, Optical Data Transport, Point-To-Point FICON at 2.125 Gbps, Rate-adjustable via SONET transport at STS-1-38v, 1838.592 Mbps Nominal Payload Rate	√	Not Applicable	√	Not Applicable	Not Applicable
OPEI	LAN, Optical Data Transport, Point-To-Point FICON at 2.125 Gbps, Protected, Rate-Adjustable via SONET transport at STS-1-38v, 1838.592 Mbps Nominal Payload Rate	√	Not Applicable	Not Applicable	Not Applicable	Not Applicable
OPF-	LAN, Optical Data Transport, Fibre Channel at 1.0625 Gbps	Not Applicable	√	Not Applicable	Not Applicable	√
OPFH	LAN, Optical Data Transport, Fibre Channel at 1.0625 Gbps, Rate-adjustable via SONET transport at STS-1-19v, 919.296 Mbps Nominal Payload Rate	√	Not Applicable	√	Not Applicable	Not Applicable
OPFA	LAN, Optical Data Transport, Fibre Channel at 1.0625 Gbps, Protected, Rate-Adjustable via SONET transport at STS-1-19v, 919.296 Mbps Nominal Payload Rate	√	Not Applicable	√	Not Applicable	Not Applicable

Table 3-9 OWS NC Codes for SAN (Continued)

NC Code	Description	Equipment Platform 1	Equipment Platform 2	Equipment Platform		Equipment Platform 4
				3A	3B	
Storage Area Network (SAN) Protocol Channels						
OPJ-	LAN, Optical Data Transport, Fibre Channel at 2.125 Gbps	Not Applicable	√	Not Applicable	Not Applicable	√
OPJH	LAN, Optical Data Transport, Fibre Channel at 2.125 Gbps, Rate-adjustable via SONET transport at STS-1-38v, 1838.592 Mbps Nominal Payload Rate	√	Not Applicable	√	Not Applicable	Not Applicable
OPJI	LAN, Optical Data Transport, Fibre Channel at 2.125 Gbps, Protected, Rate-Adjustable via SONET transport at STS-1-38v, 1838.592 Mbps Nominal Payload Rate	√	Not Applicable	√	Not Applicable	Not Applicable
OPL-	LAN, Optical Data Transport, Fibre Channel at 4.25 Gbps	Not Applicable	√	Not Applicable	Not Applicable	√
OPLF	LAN, Optical Data Transport, Fibre Channel at 4.25 Gbps, Rate-adjustable via SONET transport at STS-1-76v, 3677.184 Mbps Nominal Payload Rate	√	Not Applicable	√	Not Applicable	Not Applicable
OPLE	LAN, Optical Data Transport, Fibre Channel at 4.25 Gbps, Protected, Rate-Adjustable via SONET transport at STS-1-76v, 3677.184 Mbps Nominal Payload Rate	√	Not Applicable	√	Not Applicable	Not Applicable
OPLP	LAN, Optical Data Transport, Fibre Channel at 4.25 Gbps, Protected, Requires Protected Infrastructure	√	Not Applicable	Not Applicable	√	√
OPM-	LAN, Optical Data Transport, Fibre Channel at 10 Gbps	√	√	√	Not Applicable	√
OPMP	LAN, Optical Data Transport, Fibre Channel at 10 Gbps, Requires protected Infrastructure	√	√	√	Not Applicable	√

Table 3-10 OWS NC Codes for Ethernet

NC Code	Description	Equipment Platform 1	Equipment Platform 2	Equipment Platform 3		Equipment Platform 4
				3A	3B	
Ethernet Protocol Channels						
KQFT	Ethernet, Rate-adjustable 100 Mbps, Full Duplex - Rate based on SONET Transport, STS-1-3v, 145.152 Mbps Nominal Payload Rate	GF	Not Applicable	GF	Not Applicable	Not Applicable
KQPT	Rate-Adjustable 100 Mbps Ethernet, Protected Full Duplex - Rate based on SONET transport, STS-1-3v, 145.152 Mbps Nominal Payload Rate	GF	Not Applicable	Not Applicable	Not Applicable	Not Applicable
KFL-	Ethernet at 1 Gbps, LAN	√	√	√	√	Not Applicable
KRRG	Ethernet, Rate-adjustable 1 Gbps (Full Duplex), Rate based on SONET transport with Hi-Order VCAT, STS-3c-7v, 1048.32 Mbps Nominal Payload Rate	√	Not Applicable	√	Not Applicable	√
KRRQ	Rate-Adjustable 1 Gbps Ethernet (Full Duplex), Rate based on SONET transport with Hi-Order VCAT, Protected, STS-3c-7v, 1048.32 Mbps Nominal Payload Rate	√	Not Applicable	√	Not Applicable	Not Applicable
KGW-	Ethernet at 10 Gbps, WAN (9.95328 Gbps)	√	√	√	√	√
KGWP	Ethernet at 10 Gbps, WAN (9.95328 Gbps), Protected	√	√	√	√	√
KGL-	Ethernet at 10 Gbps, LAN PHY at 10.3125 Gbps , Ethernet frames, payload only	√	√	√	√	√
KGLP	Ethernet at 10 Gbps, LAN PHY at 10.3125 Gbps, Ethernet frames, payload only, Protected	√	√	√	√	√

Table 3-10 OWS NC Codes for Ethernet

NC Code	Description	Equipment Platform 1	Equipment Platform 2	Equipment Platform 3		Equipment Platform 4
				3A	3B	
Ethernet Protocol Channels						
KHL-	Ethernet at 40 Gbps, full duplex LAN	√	Not Applicable	Not Applicable	√	√
KHLP	Ethernet at 40 Gbps, full duplex LAN, Protected	Not Applicable	Not Applicable	Not Applicable	√	√
KJL	Ethernet at 100 Gbps, Full Duplex LAN	√	√	√	√	√
KJLP	Ethernet at 100 Gbps, Full Duplex LAN, Protected	√	Not Applicable	√	√	√

Table 3-11 OWS NC Codes for OTN

NC Code	Description	Equipment Platform 1	Equipment Platform 2	Equipment Platform		Equipment Platform 4
				3A	3B	
Optical Transport Network (OTN) Protocol Channels						
OJ--	Optical Transport Network (OTN) per ITU-T G.709 OTU1 (255/238 x 2.488 3202.666057143 Gbps) also referred to as 2.7 Gbps, Point-to-Point	√	√	√	√	√
OJT-	Optical Transport Network (OTN) per ITU-T G.709 OTU1 (255/238 x 2.488 3202.666057143 Gbps) also referred to as 2.7 Gbps, Point-to-Point, Requires protected infrastructure	√	√	√	√	√
OK--	Optical Transport Network (OTN) OTU2 per ITU-T G.709, Point-to-Point at 10.709 Gbps	√	√	√	√	√
OKT-	Optical Transport Network (OTN) OTU2 per ITU-T G.709, Point-to-Point at 10.709 Gbps, Requires protected infrastructure	√	√	√	√	√
OKD-	Optical Transport Network (OTN) OTU2e per ITU-T G.Sup43 and G.709, Point-to-Point overclocked to 11.0957 Gbps	√	√	√	√	√
OKDP	Optical Transport Network (OTN) OTU2e per ITU-T G.Sup43 and G.709, Point-to-Point overclocked to 11.0957 Gbps, Requires protected infrastructure	√	√	√	√	√
OL--	Optical Transport Network (OTN) per ITU-T G.709 OTU3 (255/236 x 39.813120 Gbps = 43.018413559 Gbps) also referred to as 43 Gbps, Point-to-Point	√	Not Available	Not Available	Not Available	√
OLT-	Optical Transport Network (OTN) per ITU-T G.709 OTU3 (255/236 x 39.813120 Gbps = 43.018413559 Gbps) also referred to as 43 Gbps, Point-to-Point, Requires protected infrastructure	√	Not Available	Not Available	Not Available	√
OM--	Optical Transport Network (OTN) per ITU-T G.709 OTU4 also referred to as 111.108 Gbps, Point-to-Point	√	Not Available	√	√	√
OMT-	Optical Transport Network (OTN) per ITU-T G.709 OTU4 also referred to as 111.108 Gbps, Point-to-Point, Requires protected infrastructure	√	Not Available	Not Available	√	√

Table 3-12 OWS NC Codes for SONET

NC Code	Description	Equipment Platform 1	Equipment Platform 2	Equipment Platform		Equipment Platform 4
				3A	3B	
SONET Protocol Channels						
OB-Z	SONET, OC-3, 155.520 Mbps, Point-to-Point channel, This service is transported over non-SONET infrastructure (overhead remains transparent to provider)	√	√	√	√	√
OD-Z	SONET, OC-12, 622.080 Mbps, Point-to-Point channel, This service is transported over non-SONET infrastructure (overhead remains transparent to provider)	√	√	√	√	√
OF-Z	SONET, OC-48, 2488.320 Mbps, Point-to-Point channel, This service is transported over non-SONET infrastructure (overhead remains transparent to provider)	√	√	√	√	√
OFTZ	SONET, OC-48, 2488.320 Mbps, Point to Point Requiring protected Infrastructure, This service is transported over non-SONET infrastructure (overhead remains transparent to provider)	√	√	√	√	√
OG-Z	SONET, OC-192, 9953.280 Mbps, Point-to-Point channel, This service is transported over non-SONET infrastructure (overhead remains transparent to provider)	√	√	√	√	√
OGTZ	SONET, OC-192, 9953.280 Mbps, Point to Point Requiring protected Infrastructure, This service is transported over non-SONET infrastructure (overhead remains transparent to provider)	√	√	√	√	√
OH--	SONET, OC-768, 39813.12 Mbps, Point-to-Point channel	√	√	√	Not Available	√
OHT-	SONET, OC-768, 39813.12 Mbps, Point to Point Requiring protected Infrastructure	√	Not Available	Not Available	Not Available	√

See Tables 3-13 to 3-20 for the possible compatible NCI Codes to use at the ends of each Network Channel. While the protocol and bit rate must be the same at both ends of the channel, the wavelength may be different for a given physical layer implementation (e.g., 1000BASE-LX or 1000BASE-ZX for optical Gigabit Ethernet). Multiplexing functions such as Ethernet-to-SONET or electrical interfaces are not available with OWS though may be provided in conjunction with CenturyLink Synchronous Service Transport (SST).

3.7 NCI Code Form and Components

The Network Channel Interface (NCI) Code provides the means to define the Network Interface physical and optical characteristics for the service order, design and circuit provisioning processes. The full NCI Code format has fields not used for optical services. Only those fields relevant to OWS interfaces are discussed here.

An NCI Code has the form 02OPF.A02. The period between the characters is a delimiter, which is used for improved clarity. It causes the subsequent Protocol Option Codes to stand out. An NCI Code has no dashes (-).

Figure 3-2 illustrates the components of the OWS Network Channel Interface Codes.

Figure 3-2 OWS NCI Code Example

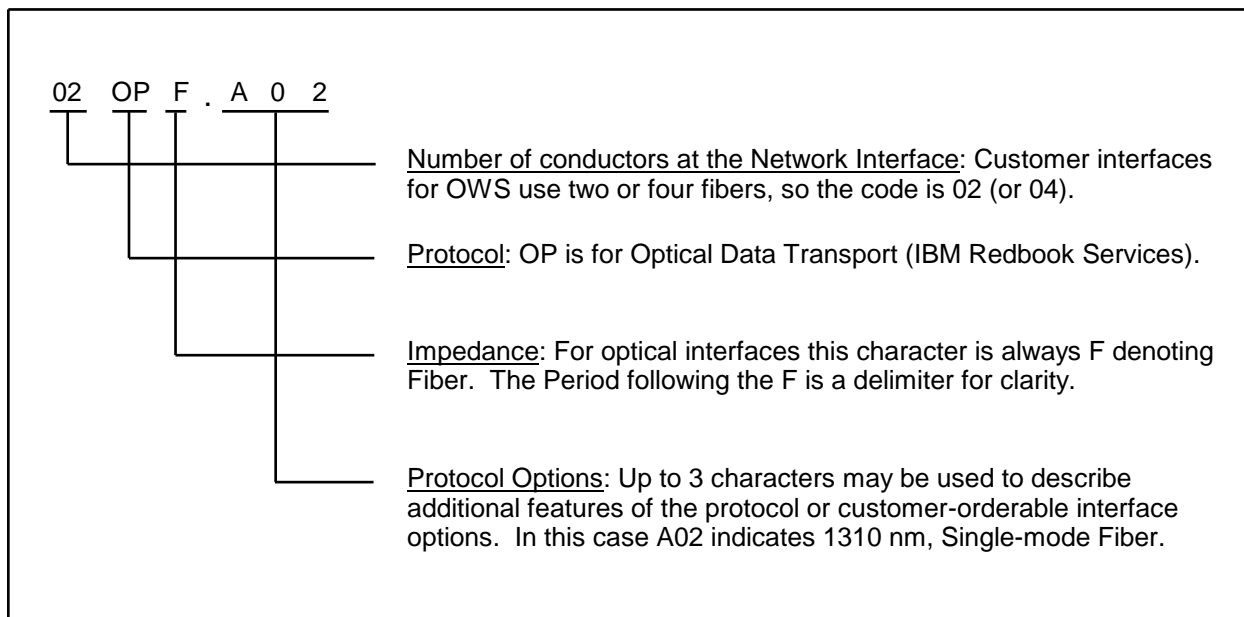

3.8 OWS Network Channel Interface Codes

Tables 3-13 to 3-20 list the optical NCI Codes available with CenturyLink OWS. Note that the NCI Codes are different for a Network Interface at Access Customer (Carrier) and End User Customer Premises locations vs. at a CenturyLink Central Office (CO), and also that OWS protocol channels are ordered without a dedicated ROADM system or DWDM channel capacity requirement.

Table 3-13 OWS NCI Codes at Access Carrier and End User
Customer Premises for SAN

NCI Code	Description	Protocol Channels	Equipment Platform 1	Equipment Platform 2	Equipment Platform		Equipment Platform 4
					3A	3B	
Storage Area Network (SAN)							
02OPF.A02 (2) 02OPF.A02 ^{1,2}	2 Conductors 4 (equivalent) Conductors Optical Data Transport (IBM Redbook Services), 1310 nm, Single-mode Fiber	FICON at 1.0625 Gbps	GF ⁶	GF ⁶	GF ⁶	Not Available	Not Available
		FICON at 2.125 Gbps	GF ⁶	GF ⁶	GF ⁶	Not Available	Not Available
		Fibre Channel at 1.0625 Gbps	√	√	√	Not Available	√
		Fibre Channel at 2.125 Gbps	√	√	√	Not Available	√
		Fibre Channel at 4.25 Gbps	√	√	√	Not Available	√
		Fibre Channel at 10.52 Gbps	√	√	√	Not Available	√
02OPF.A03 (2) 02OPF.A03 ^{1,2}	2 Conductors 4 (equivalent) Conductors Optical Data Transport (IBM Redbook Services), 1550 nm, Single-mode Fiber	FICON at 1.0625 Gbps	GF ⁶	GF ⁶	GF ⁶	Not Available	Not Available
		FICON at 2.125 Gbps	GF ⁶	GF ⁶	GF ⁶	Not Available	Not Available
		Fibre Channel at 1.0625 Gbps	√	√	√	Not Available	√
		Fibre Channel at 2.125 Gbps	√	√	√	Not Available	√

Table 3-14 OWS NCI Codes at Access Carrier and End User
Customer Premises for Ethernet

NCI Code	Description	Protocol Channels	Equipment Platform 1	Equipment Platform 2	Ethernet Platform		Equipment Platform 4
					3A	3B	
Ethernet							
02LNF.A02 (2) 02LNF.A02 ^{1,2}	2 Conductors 4 (equivalent) Conductors Local Area Network Interface, 1310 nm, Single-mode Fiber	Fast Ethernet	GF ⁶	Not Available	GF ⁶	Not Available	Not Available
		Gigabit Ethernet	√	√	√	√	√
		10 Gigabit Ethernet WAN PHY	√	√	√	√	√
		10 Gigabit Ethernet LAN PHY	√	√	√	√	√
02LNF.A03 (2) 02LNF.A03 ^{1,2}	2 Conductors 4 (equivalent) Conductors Local Area Network Interface, 1550 nm, Single-mode Fiber	Gigabit Ethernet	√	√	√	√	√
		10 Gigabit Ethernet WAN PHY	√	√	√	√	√
		10 Gigabit Ethernet LAN PHY	√	√	√	√	√

Table 3-14 OWS NCI Codes at Access Carrier and End User
Customer Premises for Ethernet (Continued)

NCI Code	Description	Protocol Channels	Equipment Platform 1	Equipment Platform 2	Ethernet Platform		Equipment Platform 4
					3A	3B	
Ethernet							
02LNF.4LL (2) 02LNF.4LL ^{1,2}	2 Conductors 4 (equivalent) Conductors 40GBASE-LR4 with 1310 nm 40 Gbps PHY using 40GBASE-R encoding over four WDM lanes on single-mode fiber, with reach up to at least 10 km per IEEE 802.3ba with Provider optical loopback/monitoring device.	40 Gigabit Ethernet LAN PHY	√	Not Available	Not Available	√	√
02LNF.CL4 (2) 02LNF.CL4 ^{1,2}	2 Conductors 4 (equivalent) Conductors Local Area Network (LAN) Interface, 100GBASE-LR4, 100 Gbps PHY using 100GBASE-R encoding over four WDM lanes via two single-mode fibers, with reach up to at least 10 km per IEEE 802.3ba-2010	100 Gigabit Ethernet	√	√	√	√	√

Table 3-15 OWS NCI Codes at Access Carrier and End User
Customer Premises for OTN

NCI Code	Description	Protocol Channels	Equipment Platform 1	Equipment Platform 2	Equipment Platform		Equipment Platform 4
					3A	3B	
Optical Transport Network (OTN)							
02OTF.102 (2) 02OTF.102 ^{1,2}	2 Conductors 4 (equivalent) Conductors Optical Transport Network (OTN) Optical Interface, OTU1 with 1310 nm, Single-mode Fiber	OTU1	√	√	√	√	√
02OTF.103 (2) 02OTF.103 ^{1,2}	2 Conductors 4 (equivalent) Conductors Optical Transport Network (OTN) Optical Interface, OTU1 with 1550 nm, Single-mode Fiber	OTU1	√	√	√	√	√
02OTF.202 (2) 02OTF.202 ^{1,2}	2 Conductors 4 (equivalent) Conductors OTN Interface, OTU2 with 1310 nm, Single-mode Fiber	OTU2	√	√	√	√	√
02OTF.203 (2) 02OTF.203 ^{1,2}	2 Conductors 4 (equivalent) Conductors OTN Interface, OTU2 with 1550 nm, Single-mode Fiber	OTU2	√	√	√	√	√
02OTF.2E2 (2) 02OTF.2E2 ^{1,2}	2 Conductors 4 (equivalent) Conductors OTN Interface, OTU2e with 1310 nm, Single-mode Fiber	OTU2e	√	√	√	√	√

Table 3-15 OWS NCI Codes at Access Carrier and End User
Customer Premises for OTN (Continued)

NCI Code	Description	Protocol Channels	Equipment Platform 1	Equipment Platform 2	Equipment Platform		Equipment Platform 4
					3A	3B	
Optical Transport Network (OTN)							
02OTF.2E3 (2) 02OTF.2E3 ^{1,2}	2 Conductors 4 (equivalent) Conductors OTN Interface, OTU2e with 1550 nm, Single-mode Fiber	OTU2e	√	√	√	√	√
02OTF.302 (2) 02OTF.302 ^{1,2}	2 Conductors 4 (equivalent) Conductors Optical Transport Network (OTN) Optical Interface, OTU3 with 1310 ³ nm, Single-mode Fiber	OTU3	√	Not Available	Not Available	Not Available	√
02OTF.303 (2) 02OTF.303 ^{1,2}	2 Conductors 4 (equivalent) Conductors Optical Transport Network (OTN) Optical Interface, OTU3 with 1550 nm, Single-mode Fiber	OTU3	√	Not Available	Not Available	Not Available	√
02OTF.402 (2) 02OTF.402 ^{1,2}	2 Conductors 4 (equivalent) Conductors Optical Transport Network (OTN) Optical Interface, OTU4 with 1310 ³ nm, Single-mode Fiber	OTU4	√	Not Available	√	√	√

Table 3-16 OWS NCI Codes at Access Carrier and End User
Customer Premises for SONET

NCI Code	Description	Protocol Channels	Equipment Platform 1	Equipment Platform 2	Equipment Platform		Equipment Platform 4
					3A	3B	
SONET							
02SOF.D 04SOF.D ²	2 Conductors 4 Conductors SONET/SDH Optical Interface, ANSI: Intermediate Reach – 1, Single Longitudinal Mode Laser, 1310 nm (ITU-T: S-16.1 & SLM) ⁴	OC-3	√	√	√	√	√
		OC-12	√	√	√	√	√
		OC-48	√	√	√	√	√
02SOF.B 04SOF.B ²	2 Conductors 4 Conductors SONET/SDH Optical Interface, ANSI: Long Reach – 1, Single Longitudinal Mode Laser, 1310 nm (ITU-T: L-1.1, L-4.1, L-16.1, or L-64.1 & SLM)	OC-3	√	Not Available	√	√	√
		OC-12	√	Not Available	√	√	√
		OC-48	√	Not Available	√	√	√

Table 3-16 OWS NCI Codes at Access Carrier and End User
Customer Premises for SONET (Continued)

NCI Code	Description	Protocol Channels	Equipment Platform 1	Equipment Platform 2	Equipment Platform		Equipment Platform 4
					3A	3B	
SONET							
02SOF.G 04SOF.G ²	2 Conductors 4 Conductors SONET/SDH Optical Interface, ANSI: Long Reach – 2, Single Longitudinal Mode Laser, 1550 nm (ITU-T: L-1.2, L-4.2, L-16.2, or L-64.2 & SLM)	OC-3 OC-12 OC-48	√ √ √	√ √ √	√ √ √	√ √ √	√ √ √
02SOF.M 04SOF.M ²	2 Conductors 4 Conductors SONET/SDH Optical Interface, ANSI: Short Reach – 1, Single Longitudinal Mode Laser, 1310 nm (ITU-T: I-64.1 or VSR2000-3R1 & SLM)	OC-192	√	√	√	√	√
02SOF.L 04SOF.L ²	2 Conductors 4 Conductors SONET/SDH Optical Interface, ANSI: Intermediate Reach – 2, Single Longitudinal Mode Laser, 1550 nm (ITU-T: S-1.2 or S-4.2 or S-16.2 or S-64.2 & SLM)	OC-192	√	√	√	√	√
02SOF.N 04SOF.N ²	2 Conductors 4 Conductors SONET/SDH Optical Interface, Short Reach – 2, Single Longitudinal Mode Laser, 1550 nm (ITU-T: I-64.2 or VSR2000-3R2/VSR2000-3R3/VSR2000-3R5 & SLM)	OC-768	GF ⁶	GF ⁶	GF ⁶	Not Available	GF ⁶

Tables 3-13 to 3-16 Notes:

1. 4 fiber Network Interfaces require the ordering of 2 similar NCI-NC-Sec NCI protocol channels for those NCI Codes listed as (2) 02xxF.xxx specifying 4 (equivalent) Conductors.
2. These codes are used to identify the OWS customer-specified option of two unprotected (dual path) protocol channels with CenturyLink-provided diversity. See Chapter 2 for further information.
3. See Table 3-7 for the WDM lane (wavelength) assignments.
4. While the indication is that of an SLM laser, an MLM transmitter may be used to provide OWS OC-3 and OC-12 singlemode fiber NIs.
5. Specific protocol or bit rate information is specified by the corresponding Protocol Channel NC Code from Tables 3-9 to 3-12.
6. GF (Grandfathered) services will continue to be supported on existing contracts until the platform supporting that service has reached end of life or the current contract expires. No new orders or renewals will be accepted.

Table 3-17 OWS Protocol Channel NCI Codes at CenturyLink COs for SAN

NCI Code	Description	Protocol Channels	Equipment Platform 1	Equipment Platform 2	Equipment Platform		Equipment Platform 4
					3A	3B	
Storage Area Network (SAN)							
02QBF.P02 (2) 02QBF.P02 ^{1,2}	2 Conductors	FICON at 1.0625 Gbps	GF ⁵	GF ⁵	GF ⁵	Not Available	Not Available
	4 (equivalent) Conductors	FICON at 2.125 Gbps	GF ⁵	GF ⁵	GF ⁵	Not Available	Not Available
	Central Office Manual Cross Connect Termination With No Sub-Rating Capability For Non-Multiplexed Facilities Only, IBM Redbook Optical, 1310 nm, Single-mode Fiber	Fibre Channel at 1.0625 Gbps	√	√	√	Not Available	√
		Fibre Channel at 2.125 Gbps	√	√	√	Not Available	√
		Fibre Channel at 4.25 Gbps	√	√	√	Not Available	√
		Fibre Channel at 10.52 Gbps	√	√	√	Not Available	√
02QBF.P03 (2) 02QBF.P03 ^{1,2}	2 Conductors	FICON at 1.0625 Gbps	GF ⁵	GF ⁵	GF ⁵	Not Available	Not Available
	4 (equivalent) Conductors	FICON at 2.125 Gbps	GF ⁵	GF ⁵	GF ⁵	Not Available	Not Available
	Central Office Manual Cross Connect Termination With No Sub-Rating Capability For Non-Multiplexed Facilities Only, IBM Redbook Optical, 1550 nm, Single-mode Fiber	Fibre Channel at 1.0625 Gbps	√	√	√	Not Available	√
		Fibre Channel at 2.125 Gbps	√	√	√	Not Available	√

Table 3-18 OWS Protocol Channel NCI Codes at CenturyLink COs for Ethernet

NCI Code	Description	Protocol Channels	Equipment Platform 1	Equipment Platform 2	Equipment Platform		Equipment Platform 4
					3A	3B	
Ethernet							
02QBF.K02 (2) 02QBF.K02 ^{1,2}	2 Conductors	Fast Ethernet	GF ⁵	Not Available	GF ⁵	Not Available	Not Available
	4 (equivalent) Conductors	Gigabit Ethernet	√	√	√	√	√
	Central Office Manual Cross Connect Termination With No Sub-Rating Capability For Non-Multiplexed Facilities Only, Ethernet, 1310 nm, Single-mode Fiber	10 Gigabit Ethernet WAN PHY	√	√	√	√	√
		10 Gigabit Ethernet LAN PHY	√	√	√	√	√
02QBF.K03 (2) 02QBF.K03 ^{1,2}	2 Conductors	Gigabit Ethernet	√	√	√	√	√
	4 (equivalent) Conductors	10 Gigabit Ethernet WAN PHY	√	√	√	√	√
	Central Office Manual Cross Connect Termination With No Sub-Rating Capability For Non-Multiplexed Facilities Only, Ethernet, 1550 nm, Single-mode Fiber	10 Gigabit Ethernet LAN PHY	√	√	√	√	√
02QBF.4L4 (2) 02QBF.4L4 ^{1,2}	2 Conductors	40 Gigabit Ethernet LAN PHY	√	Not Available	Not Available	√	√
	4 (equivalent) Conductors						
	40GBASE-LR4, 40 Gbps PHY using 40GBASE-R encoding over four WDM lanes on 1310 nm single-mode fiber, with reach up to at least 10 km per IEEE 802.3ba-2010.						

Table 3-18 OWS Protocol Channel NCI Codes at CenturyLink COs for Ethernet (Continued)

NCI Code	Description	Protocol Channels	Equipment Platform 1	Equipment Platform 2	Equipment Platform		Equipment Platform 4
					3A	3B	
Ethernet							
02QBF.CL4 (2) 02QBF.CL4 ^{1,2}	2 Conductors 4 (equivalent) Conductors Central Office Manual cross-connect Termination With No Sub-Rating Capability For Non-Multiplexed Facilities Only, 100GBASE-LR4, 100 Gbps PHY using 100GBASE-R encoding over four WDM lanes via two single-mode fibers, with reach up to at least 10 km per IEEE 802.3ba-2010	100 Gigabit Ethernet	√	√	√	√	√

Table 3-19 OWS Protocol Channel NCI Codes at CenturyLink COs for OTN

NCI Code	Description	Protocol Channels	Equipment Platform 1	Equipment Platform 2	Equipment Platform		Equipment Platform 4
					3A	3B	
Optical Transport Network (OTN)							
02QBF.102 (2) 02QBF.102 ^{1,2}	2 Conductors 4 (equivalent) Conductors Central Office Manual cross-connect Termination With No Sub-Rating Capability For Non-Multiplexed Facilities Only, OTU1 with 1310 nm, Single-mode Fiber	OTU1	√	√	√	√	√
02QBF.103 (2) 02QBF.103 ^{1,2}	2 Conductors 4 (equivalent) Conductors Central Office Manual cross-connect Termination With No Sub-Rating Capability For Non-Multiplexed Facilities Only, OTU1 with 1550 nm, Single-mode Fiber	OTU1	√	√	√	√	√
02QBF.202 (2) 02QBF.202 ^{1,2}	2 Conductors 4 (equivalent) Conductors Central Office Manual Cross Connect Termination With No Sub-Rating Capability For Non-Multiplexed Facilities Only, OTU2 with 1310 nm, Single-mode Fiber	OTU2	√	√	√	√	√

Table 3-19 OWS Protocol Channel NCI Codes at CenturyLink COs for OTN (Continued)

NCI Code	Description	Protocol Channels	Equipment Platform 1	Equipment Platform 2	Equipment Platform		Equipment Platform 4
					3A	3B	
Optical Transport Network (OTN)							
02QBF.203 (2) 02QBF.203 ^{1,2}	2 Conductors 4 (equivalent) Conductors Central Office Manual Cross Connect Termination With No Sub-Rating Capability For Non-Multiplexed Facilities Only, OTU2 with 1550 nm, Single-mode Fiber	OTU2	√	√	√	√	√
02QBF.2E2 (2) 02QBF.2E2 ^{1,2}	2 Conductors 4 (equivalent) Conductors Central Office Manual Cross Connect Termination With No Sub-Rating Capability For Non-Multiplexed Facilities Only, OTU2e with 1310 nm, Single-mode Fiber	OTU2e	√	√	√	√	√
02QBF.2E3 (2) 02QBF.2E3 ^{1,2}	2 Conductors 4 (equivalent) Conductors Central Office Manual Cross Connect Termination With No Sub-Rating Capability For Non-Multiplexed Facilities Only, OTU2e with 1550 nm, Single-mode Fiber	OTU2e	√	√	√	√	√

Table 3-19 OWS Protocol Channel NCI Codes at CenturyLink COs for OTN (Continued)

NCI Code	Description	Protocol Channels	Equipment Platform 1	Equipment Platform 2	Equipment Platform		Equipment Platform 4
					3A	3B	
Optical Transport Network (OTN)							
02QBF.302 (2) 02QBF.302 ^{1,2}	2 Conductors 4 (equivalent) Conductors Central Office Manual cross-connect Termination With No Sub-Rating Capability For Non-Multiplexed Facilities Only, OTU3 with 1310 ³ nm, Single-mode Fiber	OTU3	√	Not Available	Not Available	Not Available	√
02QBF.303 (2) 02QBF.303 ^{1,2}	2 Conductors 4 (equivalent) Conductors Central Office Manual cross-connect Termination With No Sub-Rating Capability For Non-Multiplexed Facilities Only, OTU3 with 1550 nm, Single-mode Fiber	OTU3	√	Not Available	Not Available	Not Available	√
02QBF.402 (2) 02QBF.402 ^{1,2}	2 Conductors 4 (equivalent) Conductors Central Office Manual cross-connect Termination With No Sub-Rating Capability For Non-Multiplexed Facilities Only, OTU4 with 1310 ³ nm, Single-mode Fiber	OTU4	√	Not Available	√	√	√

Table 3-20 OWS Protocol Channel NCI Codes at CenturyLink COs for SONET

NCI Code	Description	Protocol Channels	Equipment Platform 1	Equipment Platform 2	Equipment Platform		Equipment Platform 4
					3A	3B	
SONET							
02QBF.LL	2 Conductors	OC-3	√	√	√	√	√
04QBF.LL ²	4 Conductors	OC-12	√	√	√	√	√
	Central Office Manual Cross Connect Termination With No Sub-Rating Capability For Non-Multiplexed Facilities Only, SONET/SDH Optical on a fiber distribution bay	OC-48	√	√	√	√	√
		OC-192	√	√	√	√	√
		OC-768	GF ⁵	GF ⁵	GF ⁵	Not Available	GF ⁵

Tables 3-17 to 3-20 Notes:

1. 4 fiber Network Interfaces require the ordering of 2 similar NCI-NC-Sec NCI protocol channels for those NCI Codes listed as (2) 02xxF.xxx specifying 4 (equivalent) Conductors.
2. These codes are used to identify the OWS customer-specified option of two unprotected (dual path) protocol channels with CenturyLink-provided diversity. See Chapter 2 for further information.
3. See Table 3-7 for the WDM lane (wavelength) assignments.
4. Specific protocol or bit rate information is specified by the corresponding Protocol Channel NC Code from Tables 3-9 to 3-12.
5. GF (Grandfathered) services will continue to be supported on existing contracts until the platform supporting that service has reached end of life or the current contract expires. No new orders or renewals will be accepted.

3.9 OWS NC/NCI Code Combinations

Tables 3-21 to 3-24 list all of the valid NC Code, Primary and Secondary (Sec) NCI Code combinations for ordering CenturyLink OWS. See Sections 3.6 and 3.8 for code descriptions, applicability and restrictions.

Table 3-21 NC Code, Primary and Secondary NCI Code Combinations for OWS
Point-to-Point Protocol Channels for SAN

Protocol	NC Code	Location	NCI	Location	Sec NCI
Storage Area Network (SAN)					
FICON at 1.0625 Gbps (Grandfathered)	OPDH or OPDA	Carrier premises	02OPF.A02 or 02OPF.A03	Carrier premises	02OPF.A02 or 02OPF.A03
		Carrier premises	02OPF.A02 or 02OPF.A03	Central Office	02QBF.P02 or 02QBF.P03
		Carrier premises	02OPF.A02 or 02OPF.A03	End User premises	02OPF.A02 or 02OPF.A03
		Central Office	02QBF.P02 or 02QBF.P03	Central Office	02QBF.P02 or 02QBF.P03
		Central Office	02QBF.P02 or 02QBF.P03	End User premises	02OPF.A02 or 02OPF.A03
		End User premises	02OPF.A02 or 02OPF.A03	End User premises	02OPF.A02 or 02OPF.A03

Table 3-21 NC Code, Primary and Secondary NCI Code Combinations for OWS
Point-to-Point Protocol Channels for SAN

Protocol	NC Code	Location	NCI	Location	Sec NCI
Storage Area Network (SAN)					
FICON at 2.125 Gbps (Grandfathered)	OPEH or OPEI	Carrier premises	02OPF.A02 or 02OPF.A03	Carrier premises	02OPF.A02 or 02OPF.A03
		Carrier premises	02OPF.A02 or 02OPF.A03	Central Office	02QBF.P02 or 02QBF.P03
		Carrier premises	02OPF.A02 or 02OPF.A03	End User premises	02OPF.A02 or 02OPF.A03
		Central Office	02QBF.P02 or 02QBF.P03	Central Office	02QBF.P02 or 02QBF.P03
		Central Office	02QBF.P02 or 02QBF.P03	End User premises	02OPF.A02 or 02OPF.A03
		End User premises	02OPF.A02 or 02OPF.A03	End User premises	02OPF.A02 or 02OPF.A03

Table 3-21 NC Code, Primary and Secondary NCI Code Combinations for OWS
Point-to-Point Protocol Channels for SAN (Continued)

Protocol	NC Code	Location	NCI	Location	Sec NCI
Storage Area Network (SAN)					
Fibre Channel at 1.0625 Gbps	OPF- or OPFH or OPFA	Carrier premises	02OPF.A02 or 02OPF.A03	Carrier premises	02OPF.A02 or 02OPF.A03
		Carrier premises	02OPF.A02 or 02OPF.A03	Central Office	02QBF.P02 or 02QBF.P03
		Carrier premises	02OPF.A02 or 02OPF.A03	End User premises	02OPF.A02 or 02OPF.A03
		Central Office	02QBF.P02 or 02QBF.P03	Central Office	02QBF.P02 or 02QBF.P03
		Central Office	02QBF.P02 or 02QBF.P03	End User premises	02OPF.A02 or 02OPF.A03
		End User premises	02OPF.A02 or 02OPF.A03	End User premises	02OPF.A02 or 02OPF.A03
Fibre Channel at 2.125 Gbps	OPJ- or OPJH or OPJI	Carrier premises	02OPF.A02 or 02OPF.A03	Carrier premises	02OPF.A02 or 02OPF.A03
		Carrier premises	02OPF.A02 or 02OPF.A03	Central Office	02QBF.P02 or 02QBF.P03
		Carrier premises	02OPF.A02 or 02OPF.A03	End User premises	02OPF.A02 or 02OPF.A03
		Central Office	02QBF.P02 or 02QBF.P03	Central Office	02QBF.P02 or 02QBF.P03
		Central Office	02QBF.P02 or 02QBF.P03	End User premises	02OPF.A02 or 02OPF.A03
		End User premises	02OPF.A02 or 02OPF.A03	End User premises	02OPF.A02 or 02OPF.A03

Table 3-21 NC Code, Primary and Secondary NCI Code Combinations for OWS
Point-to-Point Protocol Channels for SAN (Continued)

Protocol	NC Code	Location	NCI	Location	Sec NCI
Storage Area Network (SAN)					
Fibre Channel at 4.25 Gbps	OPL- or OPLF or OPLE or OPLP	Carrier premises	02OPF.A02	Carrier premises	02OPF.A02
		Carrier premises	02OPF.A02	Central Office	02QBF.P02
		Carrier premises	02OPF.A02	End User premises	02OPF.A02
		Central Office	02QBF.P02	Central Office	02QBF.P02
		Central Office	02QBF.P02	End User premises	02OPF.A02
		End User premises	02OPF.A02	End User premises	02OPF.A02
Fibre Channel at 10 Gbps	OPM- or OPMP	Carrier premises	02OPF.A02	Carrier premises	02OPF.A02
		Carrier premises	02OPF.A02	Central Office	02QBF.P02
		Carrier premises	02OPF.A02	End User premises	02OPF.A02
		Central Office	02QBF.P02	Central Office	02QBF.P02
		Central Office	02QBF.P02	End User premises	02OPF.A02
		End User premises	02OPF.A02	End User premises	02OPF.A02

Table 3-22 NC Code, Primary and Secondary NCI Code Combinations for OWS
Point-to-Point Protocol Channels for Ethernet

Protocol	NC Code	Location	NCI	Location	Sec NCI
Ethernet					
Fast Ethernet (Grandfathered)	KQFT or KQPT	Carrier premises	02LNF.A02	Carrier premises	02LNF.A02
		Carrier premises	02LNF.A02	Central Office	02QBF.K02
		Carrier premises	02LNF.A02	End User premises	02LNF.A02
		Central Office	02QBF.K02	Central Office	02QBF.K02
		Central Office	02QBF.K02	End User premises	02LNF.A02
		End User premises	02LNF.A02	End User premises	02LNF.A02
Gigabit Ethernet	KFL- or KRRG or KRRQ	Carrier premises	02LNF.A02 or 02LNF.A03	Carrier premises	02LNF.A02 or 02LNF.A03
		Carrier premises	02LNF.A02 or 02LNF.A03	Central Office	02QBF.K02 or 02QBF.K03
		Carrier premises	02LNF.A02 or 02LNF.A03	End User premises	02LNF.A02 or 02LNF.A03
		Central Office	02QBF.K02 or 02QBF.K03	Central Office	02QBF.K02 or 02QBF.K03
		Central Office	02QBF.K02 or 02QBF.K03	End User premises	02LNF.A02 or 02LNF.A03
		End User premises	02LNF.A02 or 02LNF.A03	End User premises	02LNF.A02 or 02LNF.A03

Table 3-22 NC Code, Primary and Secondary NCI Code Combinations for OWS
Point-to-Point Protocol Channels for Ethernet (Continued)

Protocol	NC Code	Location	NCI	Location	Sec NCI
Ethernet					
10G WAN PHY	KGW- or KGWP	Carrier premises	02LNF.A02 or 02LNF.A03	Carrier premises	02LNF.A02 or 02LNF.A03
		Carrier premises	02LNF.A02 or 02LNF.A03	Central Office	02QBF.K02 or 02QBF.K03
		Carrier premises	02LNF.A02 or 02LNF.A03	End User premises	02LNF.A02 or 02LNF.A03
		Central Office	02QBF.K02 or 02QBF.K03	Central Office	02QBF.K02 or 02QBF.K03
		Central Office	02QBF.K02 or 02QBF.K03	End User premises	02LNF.A02 or 02LNF.A03
		End User premises	02LNF.A02 or 02LNF.A03	End User premises	02LNF.A02 or 02LNF.A03
10G LAN PHY	KGL- or KGLP	Carrier premises	02LNF.A02 or 02LNF.A03	Carrier premises	02LNF.A02 or 02LNF.A03
		Carrier premises	02LNF.A02 or 02LNF.A03	Central Office	02QBF.K02 or 02QBF.K03
		Carrier premises	02LNF.A02 or 02LNF.A03	End User premises	02LNF.A02 or 02LNF.A03
		Central Office	02QBF.K02 or 02QBF.K03	Central Office	02QBF.K02 or 02QBF.K03
		Central Office	02QBF.K02 or 02QBF.K03	End User premises	02LNF.A02 or 02LNF.A03
		End User premises	02LNF.A02 or 02LNF.A03	End User premises	02LNF.A02 or 02LNF.A03

Table 3-22 NC Code, Primary and Secondary NCI Code Combinations for OWS
Point-to-Point Protocol Channels for Ethernet (Continued)

Protocol	NC Code	Location	NCI	Location	Sec NCI
Ethernet					
40 Gigabit Ethernet	KHL- or KHLP	Carrier premises	02LNF.4LL	Carrier premises	02LNF.4LL
		Carrier premises	02LNF.4LL	Central Office	02QBF.4L4
		Carrier premises	02LNF.4LL	End User premises	02LNF.4LL
		Central Office	02QBF.4L4	Central Office	02QBF.4L4
		Central Office	02QBF.4L4	End User premises	02LNF.4LL
		End User premises	02LNF.4LL	End User premises	02LNF.4LL
100 Gigabit Ethernet	KJL- or KJLP	Carrier premises	02LNF.CL4	Carrier premises	02LNF.CL4
		Carrier premises	02LNF.CL4	Central Office	02QBF.CL4
		Carrier premises	02LNF.CL4	End User premises	02LNF.CL4
		Central Office	02QBF.CL4	Central Office	02QBF.CL4
		Central Office	02QBF.CL4	End User premises	02LNF.CL4
		End User premises	02LNF.CL4	End User premises	02LNF.CL4

Table 3-23 NC Code, Primary and Secondary NCI Code Combinations for OWS
Point-to-Point Protocol Channels for OTN

Protocol	NC Code	Location	NCI	Location	Sec NCI
Optical Transport Network (OTN)					
OTU1	OJ-- or OJT-	Carrier premises	02OTF.102 or 02OTF.103	Carrier premises	02OTF.102 or 02OTF.103
		Carrier premises	02OTF.102 or 02OTF.103	Central Office	02QBF.102 or 02QBF.103
		Carrier premises	02OTF.102 or 02OTF.103	End User premises	02OTF.102 or 02OTF.103
		Central Office	02QBF.102 or 02QBF.103	Central Office	02QBF.102 or 02QBF.103
		Central Office	02QBF.102 or 02QBF.103	End User premises	02OTF.102 or 02OTF.103
		End User premises	02OTF.102 or 02OTF.103	End User premises	02OTF.102 or 02OTF.103

Table 3-23 NC Code, Primary and Secondary NCI Code Combinations for OWS
Point-to-Point Protocol Channels for OTN (Continued)

Protocol	NC Code	Location	NCI	Location	Sec NCI
Optical Transport Network (OTN)					
OTU2	OK-- or OKT-	Carrier premises	02OTF.202 or 02OTF.203	Carrier premises	02OTF.202 or 02OTF.203
		Carrier premises	02OTF.202 or 02OTF.203	Central Office	02QBF.202 or 02QBF.203
		Carrier premises	02OTF.202 or 02OTF.203	End User premises	02OTF.202 or 02OTF.203
		Central Office	02QBF.202 or 02QBF.203	Central Office	02QBF.202 or 02QBF.203
		Central Office	02QBF.202 or 02QBF.203	End User premises	02OTF.202 or 02OTF.203
		End User premises	02OTF.202 or 02OTF.203	End User premises	02OTF.202 or 02OTF.203
OTU2e	OKD- or OKDP	Carrier premises	02OTF.2E2 or 02OTF.2E3	Carrier premises	02OTF.2E2 or 02OTF.2E3
		Carrier premises	02OTF.2E2 or 02OTF.2E3	Central Office	02QBF.2E2 or 02QBF.2E3
		Carrier premises	02OTF.2E2 or 02OTF.2E3	End User premises	02OTF.2E2 or 02OTF.2E3
		Central Office	02QBF.2E2 or 02QBF.2E3	Central Office	02QBF.2E2 or 02QBF.2E3
		Central Office	02QBF.2E2 or 02QBF.2E3	End User premises	02OTF.2E2 or 02OTF.2E3
		End User premises	02OTF.2E2 or 02OTF.2E3	End User premises	02OTF.2E2 or 02OTF.2E3

Table 3-23 NC Code, Primary and Secondary NCI Code Combinations for OWS
Point-to-Point Protocol Channels for OTN (Continued)

Protocol	NC Code	Location	NCI	Location	Sec NCI
Optical Transport Network (OTN)					
OTU3	OL-- or OLT-	Carrier premises	02OTF.302 or 02OTF.303	Carrier premises	02OTF.302 or 02OTF.303
		Carrier premises	02OTF.302 or 02OTF.303	Central Office	02QBF.302 or 02QBF.303
		Carrier premises	02OTF.302 or 02OTF.303	End User premises	02OTF.302 or 02OTF.303
		Central Office	02QBF.302 or 02QBF.303	Central Office	02QBF.302 or 02QBF.303
		Central Office	02QBF.302 or 02QBF.303	End User premises	02OTF.302 or 02OTF.303
		End User premises	02OTF.302 or 02OTF.303	End User premises	02OTF.302 or 02OTF.303
OTU4	OM-- or OMT-	Carrier premises	02OTF.402	Carrier premises	02OTF.402
		Carrier premises	02OTF.402	Central Office	02QBF.402
		Carrier premises	02OTF.402	End User premises	02OTF.402
		Central Office	02QBF.402	Central Office	02QBF.402
		Central Office	02QBF.402	End User premises	02OTF.402
		End User premises	02OTF.402	End User premises	02OTF.402

Table 3-24 NC Code, Primary and Secondary NCI Code Combinations for OWS
Point-to-Point Protocol Channels for SONET

Protocol	NC Code	Location	NCI	Location	Sec NCI
SONET					
OC-3 with Transparent Overhead	OB-Z	Carrier premises	02SOF.D or 02SOF.B or 02SOF.G	Carrier premises	02SOF.D or 02SOF.B or 02SOF.G
			04SOF.D or 04SOF.B or 04SOF.G		04SOF.D or 04SOF.B or 04SOF.G
		Carrier premises	02SOF.D or 02SOF.B or 02SOF.G	Central Office	02QBF.LL
			04SOF.D or 04SOF.B or 04SOF.G		04QBF.LL
		Carrier premises	02SOF.D or 02SOF.B or 02SOF.G	End User premises	02SOF.D or 02SOF.B or 02SOF.G
			04SOF.D or 04SOF.B or 04SOF.G		04SOF.D or 04SOF.B or 04SOF.G

Table 3-24 NC Code, Primary and Secondary NCI Code Combinations for OWS
Point-to-Point Protocol Channels for SONET (Continued)

Protocol	NC Code	Location	NCI	Location	Sec NCI
SONET					
OC-3 with Transparent Overhead	OB-Z	Central Office	02QBF.LL	Central Office	02QBF.LL
			04QBF.LL		04QBF.LL
		Central Office	02QBF.LL	End User premises	02SOF.D or 02SOF.B or 02SOF.G
			04QBF.LL		04SOF.D or 04SOF.B or 04SOF.G
		End User premises	02SOF.D or 02SOF.B or 02SOF.G	End User premises	02SOF.D or 02SOF.B or 02SOF.G
			04SOF.D or 04SOF.B or 04SOF.G		04SOF.D or 04SOF.B or 04SOF.G

Table 3-24 NC Code, Primary and Secondary NCI Code Combinations for OWS
Point-to-Point Protocol Channels for SONET (Continued)

Protocol	NC Code	Location	NCI	Location	Sec NCI
SONET					
OC-12 with Transparent Overhead	OD-Z	Carrier premises	02SOF.D or 02SOF.B or 02SOF.G	Carrier premises	02SOF.D or 02SOF.B or 02SOF.G
			04SOF.D or 04SOF.B or 04SOF.G		04SOF.D or 04SOF.B or 04SOF.G
		Carrier premises	02SOF.D or 02SOF.B or 02SOF.G	Central Office	02QBF.LL
			04SOF.D or 04SOF.B or 04SOF.G		04QBF.LL
		Carrier premises	02SOF.D or 02SOF.B or 02SOF.G	End User premises	02SOF.D or 02SOF.B or 02SOF.G
			04SOF.D or 04SOF.B or 04SOF.G		04SOF.D or 04SOF.B or 04SOF.G

Table 3-24 NC Code, Primary and Secondary NCI Code Combinations for OWS
Point-to-Point Protocol Channels for SONET (Continued)

Protocol	NC Code	Location	NCI	Location	Sec NCI
SONET					
OC-12 with Transparent Overhead	OD-Z	Central Office	02QBF.LL	Central Office	02QBF.LL
			04QBF.LL		04QBF.LL
		Central Office	02QBF.LL	End User premises	02SOF.D or 02SOF.B or 02SOF.G
			04QBF.LL		04SOF.D or 04SOF.B or 04SOF.G
		End User premises	02SOF.D or 02SOF.B or 02SOF.G	End User premises	02SOF.D or 02SOF.B or 02SOF.G
			04SOF.D or 04SOF.B or 04SOF.G		04SOF.D or 04SOF.B or 04SOF.G

Table 3-24 NC Code, Primary and Secondary NCI Code Combinations for OWS
Point-to-Point Protocol Channels for SONET (Continued)

Protocol	NC Code	Location	NCI	Location	Sec NCI
SONET					
OC-48 with Transparent Overhead	OF-Z or OFTZ	Carrier premises	02SOF.D or 02SOF.B or 02SOF.G	Carrier premises	02SOF.D or 02SOF.B or 02SOF.G
			04SOF.D or 04SOF.B or 04SOF.G		04SOF.D or 04SOF.B or 04SOF.G
		Carrier premises	02SOF.D or 02SOF.B or 02SOF.G	Central Office	02QBF.LL
			04SOF.D or 04SOF.B or 04SOF.G		04QBF.LL
		Carrier premises	02SOF.D or 02SOF.B or 02SOF.G	End User premises	02SOF.D or 02SOF.B or 02SOF.G
			04SOF.D or 04SOF.B or 04SOF.G		04SOF.D or 04SOF.B or 04SOF.G

Table 3-24 NC Code, Primary and Secondary NCI Code Combinations for OWS
02LNF.4LL Point-to-Point Protocol Channels for SONET (Continued)

Protocol	NC Code	Location	NCI	Location	Sec NCI
SONET					
OC-48 with Transparent Overhead	OF-Z or OFTZ	Central Office	02QBF.LL	Central Office	02QBF.LL
			04QBF.LL		04QBF.LL
		Central Office	02QBF.LL	End User premises	02SOF.D or 02SOF.B or 02SOF.G
			04QBF.LL		04SOF.D or 04SOF.B or 04SOF.G
		End User premises	02SOF.D or 02SOF.B or 02SOF.G	End User premises	02SOF.D or 02SOF.B or 02SOF.G
			04SOF.D or 04SOF.B or 04SOF.G		04SOF.D or 04SOF.B or 04SOF.G

Table 3-24 NC Code, Primary and Secondary NCI Code Combinations for OWS
Point-to-Point Protocol Channels for SONET (Continued)

Protocol	NC Code	Location	NCI	Location	Sec NCI
SONET					
OC-192 with Transparent Overhead	OG-Z or OGTZ	Carrier premises	02SOF.M or 02SOF.L	Carrier premises	02SOF.M or 02SOF.L
			04SOF.M or 04SOF.L		04SOF.M or 04SOF.L
		Carrier premises	02SOF.M or 02SOF.L	Central Office	02QBF.LL
			04SOF.M or 04SOF.L		04QBF.LL
		Carrier premises	02SOF.M or 02SOF.L	End User premises	02SOF.M or 02SOF.L
			04SOF.M or 04SOF.L		04SOF.M or 04SOF.L
		Central Office	02QBF.LL	Central Office	02QBF.LL
			04QBF.LL		04QBF.LL
		Central Office	02QBF.LL	End User premises	02SOF.M or 02SOF.L
			04QBF.LL		04SOF.M or 04SOF.L
		End User premises	02SOF.M or 02SOF.L	End User premises	02SOF.M or 02SOF.L
			04SOF.M or 04SOF.L		04SOF.M or 04SOF.L

Table 3-24 NC Code, Primary and Secondary NCI Code Combinations for OWS
Point-to-Point Protocol Channels for SONET (Continued)

Protocol	NC Code	Location	NCI	Location	Sec NCI
SONET					
OC-768 with Transparent Overhead Grandfathered	OH-- or OHT-	Carrier premises	02SOF.N	Carrier premises	02SOF.N
			04SOF.N		04SOF.N
		Carrier premises	02SOF.N	Central Office	02QBF.LL
			04SOF.N		04QBF.LL
		Carrier premises	02SOF.N	End User premises	02SOF.N
			04SOF.N		04SOF.N
		Central Office	02QBF.LL	Central Office	02QBF.LL
			04QBF.LL		04QBF.LL
		Central Office	02QBF.LL	End User premises	02SOF.N
			04QBF.LL		04SOF.N
		End User premises	02SOF.N	End User premises	02SOF.N
			04SOF.N		04SOF.N

CONTENTS

Chapter and Section	Page
4. Performance Specifications.....	4-1
4.1 General.....	4-1
4.2 Service Availability.....	4-1
4.3 Bit Error Ratio (BER).....	4-2
4.4 Throughput.....	4-2
4.5 Delay (Latency).....	4-3
4.6 Reflectance.....	4-3
4.7 Jitter.....	4-4
4.8 Protection Switching.....	4-4
Tables	
4-1 Service Availability.....	4-2
4-2 Reflectance.....	4-3

4. Performance Specifications

4.1 General

The Optical Wavelength Service (OWS) network primarily operates at the lower SONET and/or Optical Transport Network (OTN) physical layers in support of providing transparency for the incoming customer protocols. As such, CenturyLink's performance responsibilities will be limited to the transport integrity of the underlying wavelength and protocol channel support layers only and not the customer end-to-end higher layer protocols being carried over the OWS ROADM/DWDM network.

Objectives given in this section are for all one-way system options, designed consistent with standard OTN/DWDM architectures and apply in a normal operating environment for the CenturyLink-provided portion of the customer's service. The end-to-end performance of a given protocol channel may be dictated by segments not provided by OWS.

Loopback tests should be made using the one-way limits because one direction is likely to be controlling. If these tests fail, the failed direction should be sectionalized and appropriate one-way tests made.

4.2 Service Availability

The service is available when it's in a state where it's fully useable. A service is assumed to be in the available state unless a transition to the unavailable state is observed without a subsequent transition to the available state.

Transitions between the available and unavailable states are:

- Transition to the Unavailable state occurs at the beginning of 10 consecutive Loss of Signal Seconds (LOSS) or Severely Errored Seconds (SESS).
- Transition to the Available state occurs at the beginning of 10 consecutive seconds none of which is a LOSS or SES.

LOSS and SES will be as determined by the CenturyLink Network Operations Center (NOC) monitoring of the OWS network including the evaluation of available Performance Monitoring (PM) registers, Threshold Crossing Alerts (TCAs), alarms and events logged by the CenturyLink ROADM/DWDM equipment and Operations System Support (OSS).

Each direction of the service is assumed to be in the available state unless a transition to the unavailable state is observed without a subsequent transition to the available state.

Service availability objectives are stated in terms of the channel option ordered as shown in Table 4-1. OWS channel options are described in Chapter 2.

Table 4-1 Service Availability

All protocols/bit rates	Availability (Monthly)
Unprotected channels	99.9%
Two unprotected (dual path) channels with diversity	99.95%
Protected channels	99.99%

Note: Excludes planned outages/maintenance windows, malfunction of Customer Provided Equipment or power at the premises

4.3 Bit Error Ratio (BER)

BER is defined as the ratio of the number of bit errors to the total number of bits transmitted in a given time interval.

The BER will be 10^{-10} or better for all protocol channels transported over the OWS ROADM network and may be monitored or derived via the BIP-8 overhead bytes for error detection at the applicable OTN (OTUk or ODUk) or SONET Section, Line and/or Path layers depending upon the protocol ordered and visibility along with that used for encapsulation and Digital Wrapper.

4.4 Throughput

Throughput is defined as the total capability of equipment to process or transmit data during a specified time period. The OWS network and each component in the signal path are designed and sized to deliver the full rate throughput that the customer's protocol can achieve. However, performance may be affected by the inherent delay caused by signals traveling over long distances which is a characteristic of the protocol architecture, rather than that of the OWS ROADM network.

Storage Area Network (SAN) protocols such as FICON and Fibre Channel are distance sensitive whereas the actual data throughput will depend upon the customer packet size and available buffer credits in conjunction with the end-to-end transport distance. See the ANSI and IBM references in Chapter 7 for detailed SAN requirements.

4.5 Delay (Latency)

Delay is defined as the time interval between the transmission of a signal at one point and the reception or detection of the same signal at another point. The end-to-end One-Way Delay (OWD) across the OWS Layer 1 transport network, measured from Network Interface to Network Interface will be no more than 5.2 us/km (8.4 us/mi) for each channel. This includes the OWS fiber optic propagation delay as well as that attributable to other components in the signal path for channel add-drop, regeneration or amplification per GR-499-CORE, *Transport Systems Generic Requirements (TSGR): Common Requirements*. OWS point-to-point channels do not include oversubscription or traffic flow congestion mechanisms for data protocols.

4.6 Reflectance

Reflectance is defined as the ratio in decibels (dB) of reflected power to incident power. If not controlled, reflections can degrade DWDM system performance. In general, reflection-induced degradation increases with system bit rate, optical source coherence, and fiber dispersion. By enforcing reflectance requirements on individual components placed in the fiber optic transmission span and by requiring system performance to have a tolerance to specified reflectance values from these components, the effects of fiber optic system reflection noise can be minimized.

Individual channel reflectance objectives are stated in terms of the two parameters listed in Table 4-2. Optical Return Loss (ORL) is defined as the ratio of the optical power arriving downstream at a DWDM system interface to the optical power reflected back upstream to the same interface. Additionally, receiver reflectance criteria are enforced in order to prevent multi-path interference between two or more reflections.

Table 4-2 Reflectance

Parameter	All channels
ORL (minimum)	24 dB
Receiver Reflectance (maximum)	-27 dB

Note: Including splices, connectors, attenuators, couplers, ROADMs/DWDM equipment components, Passive Dispersion Compensator devices and Optical Fiber Amplifiers

4.7 Jitter

Timing jitter is defined as the short-term variations of the significant instants of a digital signal from their ideal positions in time (where short-term implies that these variations are of frequency greater than or equal to 10 Hz).

Jitter performance and supporting characteristics of the eye mask will follow the requirements as indicated in GR-499-CORE, GR-253-CORE, *Synchronous Optical Network (SONET) Transport Systems: Common Generic Criteria* including the Category II jitter transfer and tolerance criteria along with ANSI T1.105.03-2003(R2008), *Synchronous Optical Network (SONET) - Jitter and Wander at Network and Equipment Interfaces*; ITU-T G.825, *The control of jitter and wander within digital networks which are based on the synchronous digital hierarchy (SDH)* and ITU-T G.8251, *The control of jitter and wander within the optical transport network (OTN) at the OTUk layer as utilized within the OWS ROADM/DWDM equipment including client mappers, 3R regenerators, and client demappers.*

4.8 Protection Switching

Automatic Protection Switching (APS) improves the service availability and reliability performance of CenturyLink OWS by substituting backup equipment and/or an alternate fiber facility for the working signal path when failure occurs on a customer's protected transport channel.

The APS function will operate and switch the affected protocol channel(s) to the OTN (or SONET) protected facility system when a signal degradation (such as a BER threshold crossing at the ODU layer), Loss of Signal (LOS), Loss of Frame (LOF) or circuit card failure, for example is detected on the working channel depending upon CenturyLink ROADM equipment and configuration.

Once a decision is made to switch to the protect facility, the additional time required to complete the switch (i.e., switch completion time) will not exceed 50 milliseconds.

CenturyLink OWS service primarily uses two protection switching methods:

Y-Cable Protection

Y-Cable is a protection method that uses a physical cable that interfaces with the customer on one end of the cable, then splits into two and connects to two separate cards on the transport network element. Each of the two cards then takes a separate transmission path to the far end, where the physical Y-cable architecture is repeated, the two paths come together and the single end of the Y-cable hands the circuit off to the customer.

SNC Protection

SNC (SubNetwork Connection) protection uses a configuration of two paths between the near and far ends of a circuit. Software within the equipment will cause a switch between the two paths when failure occurs. No special physical cables are needed at either end. SNC protection, when available, is used with OTN protocol to envelop and transport the customer's circuit.

CONTENTS

Chapter and Section	Page
5. Maintenance.....	5-1
5.1 CenturyLink Responsibilities.....	5-1
5.2 Customer Responsibilities	5-1

5. Maintenance

5.1 CenturyLink Responsibilities

All Optical Wavelength Service (OWS) protocol channels are managed through CenturyLink Central Office (CO) ROADM network connectivity providing Operations, Administration, Maintenance and Provisioning (OAM&P) functions along with test access for non-intrusive monitoring as well as (intrusive) testing purposes.

CenturyLink's maintenance responsibilities will be limited to the transport integrity of the underlying wavelength and protocol channel physical layers only and not the customer end-to-end higher layer protocols being carried over the OWS ROADM/DWDM network.

CenturyLink is responsible for all equipment and cable on the CenturyLink side of the Network Interface and for maintaining the ROADM equipment and transmission facilities between customer-designated point-to-point protocol channel locations.

CenturyLink will notify the customer within 20 minutes of a service affecting trouble alarm received via the CenturyLink Network Operations Center (NOC).

CenturyLink will also furnish the customer a trouble reporting telephone number. The Customer Service Center will be available 24 hours a day, 7 days a week.

Upon receipt of a trouble alarm or customer report, CenturyLink will initiate action within 20 minutes to clear the trouble and will commit to a 4 hour maximum service restorable time in the event of a service interruption due to an electronic component failure. If the trouble is caused by a cable failure, the maximum service restorable time will be 8 hours.

The CenturyLink NOC will update the customer as needed during the repair phase of trouble isolation and upon resolution.

5.2 Customer Responsibilities

The customer is responsible for all equipment and cable on the customer side of the Network Interface at their locations.

The customer or their agent must sectionalize the trouble and verify that the trouble is not in the customer-owned equipment or cable before calling the CenturyLink Customer Service Center.

If the trouble is isolated to the customer-owned equipment or cable, the customer is responsible for clearing the trouble and restoring the service to normal.

Joint testing between CenturyLink and the customer may be necessary to isolate the trouble.

Model numbers and technical specifications of the Customer Provided Equipment (CPE) attached to the OWS network may also be helpful in resolving the problem.

CONTENTS

Chapter and Section	Page
6. Definitions.....	6-1
6.1 Acronyms.....	6-1
6.2 Glossary.....	6-3

6. Definitions

6.1 Acronyms

1R	Reamplification
3R	Reamplification, Reshaping and Retiming
ANSI	American National Standards Institute
APS	Automatic Protection Switching
BER	Bit Error Ratio
BIP-8	Bit Interleaved Parity 8
BITS	Building Integrated Timing Supply
BLSR	Bidirectional Line Switched Ring
CO	Central Office
CPE	Customer Provided Equipment
CPU	Central Processing Unit
dB	Decibel
dBm	Decibel reference to one milliwatt
DCC	Data Communications Channel
DIX	Digital, Intel and Xerox
DWDM	Dense WDM
FC	Fiber Connector
FDP	Fiber Distribution Panel
FEC	Forward Error Correction
Gbps	Gigabits per second
GFP	Generic Framing Procedure
GFP-F	Frame-mapped GFP
Hz	Hertz
I/O	Input/Output
IBM	International Business Machines
IEEE	Institute of Electrical and Electronics Engineers
IR	Intermediate Reach

ISO/IEC	International Organization for Standardization/International Electrotechnical Commission
ITU-T	International Telecommunication Union - Telecommunication Standardization Sector
km	Kilometer
LAN	Local Area Network
LC	Lucent or Local Connector
LOS	Loss of Signal
LOSS	Loss of Signal Seconds
LR	Long Reach
MAC	Media Access Control
MB/s	Mega Bytes per second
Mbps	Megabits per second
mi	Mile
MLM	Multi Longitudinal Mode (laser)
NC	Network Channel
NCI	Network Channel Interface
NI	Network Interface
nm	Nanometer
OADM	Optical Add-Drop Multiplexer
OC-N	Optical Carrier - level N
ODUk	Optical channel Data Unit - level k
OPUk	Optical channel Payload Unit - level k
OTN	Optical Transport Network
OTUk	Optical channel Transport Unit - level k
OWS	Optical Wavelength Service
PHY	Physical Layer entity
ppm	parts per million
ROADM	Reconfigurable OADM
Rx	Receive
S/390	System 390

SC	Subscriber Connector
SES	Severely Errored Second
SLM	Single Longitudinal Mode (laser)
SNC	SubNetwork Connection
SONET	Synchronous Optical Network
SR	Short Reach
STS	Synchronous Transport Signal
STS-N	STS level N (e.g., N = 3, 12, 48, 192 or 768)
TIA/EIA	Telecommunications Industry Association/Electronic Industries Alliance
Tx	Transmit
µm	Micron
UPC	Ultra Physical Contact
us	Microseconds
WAN	Wide Area Network
WDM	Wavelength Division Multiplexer, or Wavelength Division Multiplexing

6.2 Glossary

1R

Regeneration that includes amplification, equalization and chromatic dispersion compensation of an optical signal

3R

Regeneration with Optical-Electronic-Optical (O-E-O) conversion

Attenuator

A device inserted into the electrical or optical path to lessen or weaken the signal.

Automatic Protection Switch (APS)

A device which monitors a channel and automatically switches the channel to another facility whenever the channel fails or when specified parameters go beyond a specified threshold.

Availability

The relative amount of time that a service is “usable” by a customer, represented as a percentage over any calendar month.

Bidirectional

Optical signal transmission in both directions.

Bidirectional Line-Switched Ring (BLSR)

A bidirectional ring that uses the line level status and performance parameters to initiate Automatic Protection Switching (APS).

Bit

A binary unit of information. It is represented by one of two possible conditions, such as the value 0 or 1, on or off, high potential or low potential, conducting or not conducting, magnetized or demagnetized. A bit is the smallest unit of information, by definition.

Bit Error Ratio (BER)

The ratio of the number of bit errors to the total number of bits transmitted in a given time interval.

Bit Interleaved Parity 8 (BIP-8)

A method of error monitoring. If “even parity” is used, the transmitting equipment generates an 8-bit code over a specified portion of the signal in such a manner that the first bit of the code provides even parity over the first bit of all 8-bit sequences in the covered portion of the signal, the second bit provides even parity over the second bits of all 8-bit sequences within the specified portion, etc. Even parity is generated by setting the BIP-8 bits so that there is an even number of ones in each of all 8-bit sequences, including the BIP-8.

Bit Rate

The total number of bits per second.

Building Integrated Timing Supply (BITS)

Used for intraoffice synchronization distribution. The BITS is a master clock that distributes timing to equipment within a Central Office.

Byte

A consecutive number of bits usually constituting a complete character or symbol. If the length of the byte is not specified, it is conventionally assumed to have a length of 8-bits. In the Digital Data System, a byte refers to an arbitrary group of 8 consecutive bits; it does not correspond to a byte of customer data.

Carrier

An organization whose function is to provide telecommunications services. Examples are: Local Exchange Carriers, Interexchange Carriers, Cellular Carriers, etc.

Central Office (CO)

A local switching system (or a portion thereof) and its associated equipment located at a Wire Center.

Central Wavelength

The average of two optical wavelengths at which the spectral radiant intensity is 50% of the maximum value.

Channel

An electrical or photonic (in the case of fiber optic based transmission systems) communications path between two or more points of termination.

Chromatic Dispersion

The spreading of a light pulse in an optical fiber caused by the different group velocities of the different wavelengths composing the source spectrum.

Connection

A path between two points operating at the same layer in a network.

Connector

A mechanical device used to align and join two optical fibers. The connector provides a means for coupling and decoupling fiber to a transmitter, receiver, or another fiber.

Customer Premises

Denotes a building or portion(s) of a building occupied by a single customer or End User either as a place of business or residence. Adjacent buildings and the buildings on the same continuous property occupied by the customer and not separated by a public thoroughfare are also considered the customer's premises.

Customer Provided Equipment (CPE)

Equipment owned and maintained by the customer and located on their side of the End User Point of Termination (EU-POT) Network Interface.

Customers

Denotes any individual, partnership or corporation who subscribes to the services provided by CenturyLink customers are divided into two distinct and separate categories: (1) Carriers, who provide interexchange services for hire for others, and (2) End Users, who request services only for their own use.

Data Rate

The maximum number of bits of information that can be transmitted per second, as in a data transmission link.

Decibel (dB)

A unit measurement of transmission loss, gain, or relative level. It's the logarithmic unit of signal power ratio most commonly used in telephony. It's used to express the relationship between two signal powers, usually between two acoustical, electrical, or optical signals; it's equal to ten times the common logarithm of the ratio of the two signal powers.

Degree

The number of WDM Carrier links that a WDM Network Element supports.

Dense Wavelength Division Multiplexing (DWDM)

Merges many optical signals onto one optical fiber. Each optical signal is transmitted over a single wavelength in the 1550 nm region, and it can be spaced only 50 GHz to 200 GHz apart from another optical signal on the same fiber.

Digital Wrapper

The digital overhead and Forward Error Correction (FEC) bytes that are added to the client signal for Operations, Administration and Maintenance (OAM) functions and reliable transport over the Optical Transport Network.

Dispersion

In fiber optics, the process by which an electromagnetic signal is distorted because the various frequency components of that signal have different propagation characteristics. Dispersion also describes the relationships between the refractive index and frequency (or wavelength). Because it broadens input pulses along the length of the fiber, it is usually called "pulse spreading." Dispersion limits bandwidth in a fiber.

Dispersion-Unshifted Fiber

“Standard” singlemode fiber having a zero-dispersion wavelength in the 1310 nm region (TIA/EIA Class IVa) such as vs. dispersion-shifted singlemode fiber having a zero-dispersion wavelength in the 1550 nm region (TIA/EIA Class IVb). The zero-dispersion wavelength in an optical fiber is that where the chromatic dispersion is zero.

Diversity

Routing of customer circuits or access lines over physically separated facilities.

End User

The term “End User” denotes any customer of telecommunications service that is not a Carrier, except that a Carrier shall be deemed to be an “End User” to the extent that such Carrier uses a telecommunications service for administrative purposes without making such service available to others, directly or indirectly. The term is frequently used to denote the difference between a Carrier interface and an interface subject to unique regulatory requirements at non-Carrier customer premises (FCC Part 68, etc.).

Ethernet

A packet-switched local network design (by Xerox Corp.) employing Carrier Sense Multiple Access with Collision Detection (CSMA/CD) as an access control mechanism.

Eye Mask

A graphic presentation formed by the superimposition of the waveforms of all possible pulse sequences.

Facilities

Facilities are the transmission paths between the demarcation points serving customer locations, a demarcation point serving a customer location and a CenturyLink Central Office (CO), or two CenturyLink COs.

Fiber

A thin filament of glass that consists of a core and a cladding that is capable of carrying information in the form of light.

Frame-mapped GFP (GFP-F)

A type of GFP mapping in which a client signal frame is received and mapped in its entirety into one GFP frame.

Full Duplex

Simultaneous transmission in both directions between two points.

Gigabits per second (Gbps)

One billion (1,000,000,000) bits per second.

Input/Output (I/O)

I/O describes any operation, program, or device that transfers data to or from a computer.

Intermediate Reach (IR)

Optical interfaces referring to optical sections with system loss budgets from 0, 3 or 6 dB to 11 or 12 dB (depending on the bit rate).

Jumper

An optical fiber cable with connectors on both ends.

Kilometer (km)

One thousand (1,000) meters.

Laser

Light Amplification through Stimulated Emission Radiation. A silicon chip technology used for optical signal generation at higher bit rates and/or longer distances. Differs from a Light Emitting Diode (LED) in that the emitted light is in phase.

Layer 1

Physical Layer of the Open Systems Interconnection (OSI) model which allows the protocol to provide the transmission of information on the transmission facility. It is concerned with the physical and electrical characteristics of the interface.

Link

The physical connection and transmission medium used between a transmitter and a receiver.

Local Area Network (LAN)

A network permitting the interconnection and intercommunication of a group of computers, primarily for the sharing of resources such as data storage devices and printers.

Local Loop

The facility which connects the Serving (or other adjacent) Wire Center to the customer premises location.

Long Reach (LR)

Optical interfaces referring to optical sections with system loss budgets from 10, 11 or 16 dB to 22, 24 or 28 dB (depending on the bit rate).

Loopback

An out-of-service test procedure applied to a full duplex channel that causes a received signal to be returned to the source.

Loss of Signal (LOS)

A physical layer alarm sent by the receiver to indicate a cessation in signal transmission. For example, LOS is declared if a fiber optic cable is cut and the receiving end no longer detects any signal transmissions.

Loss of Signal Seconds (LOSS)

This parameter is a count of 1-second intervals containing one or more LOS defects.

Maximum Reach

The maximum reach of a link, expressed in kilometers that can exist without causing a possible signal degrade or failure condition.

Megabits per second (Mbps)

One million (1,000,000) bits per second.

Mesh

A network topology in which there are at least two nodes with two or more paths between them.

Micron (μm)

One millionth (10^{-6}) of a meter and commonly used to express the geometric dimensions of optical fiber.

Microsecond (μs)

One millionth (10^{-6}) of a second.

Mode

An independent light path through an optical fiber.

Multiplexer

An equipment unit to multiplex, or do multiplexing: Multiplexing is a technique of modulating (analog) or interleaving (digital) multiple, relatively narrow bandwidth channels into a single channel having a wider bandwidth (analog) or higher bit-rate (digital). The term Multiplexer implies the demultiplexing function is present to reverse the process so it is not usually stated.

Multiplexing

The sending of multiple signals or streams of information on a carrier at the same time in the form of a single, complex signal and then recovering the separate signals at the receiving end.

Nanometer (nm)

One billionth (10^{-9}) of a meter and a unit of measure commonly used to express the wavelengths of light.

Network

The interconnected telecommunications equipment and facilities.

Network Channel (NC) Code

The Network Channel (NC) Code is an encoded representation used to identify both switched and non-switched channel services. Included in this code set are customer options associated with individual channel services, or feature groups and other switched services.

Network Channel Interface (NCI) Code

The Network Channel Interface (NCI) Code is an encoded representation used to identify five (5) interface elements located at a Point of Termination (POT) at a Central Office or at the Network Interface at a customer location. The Interface code elements are: Total Conductors, Protocol, Impedances, Protocol Options, and Transmission Level Points (TLP). At a digital interface, the TLP element of the NCI Code is not used.

Network Element (NE)

A hardware only or combined hardware/software-based system that is primarily designed to directly perform a telecommunications function. For digital transmission surveillance, an NE is the part of network equipment where a transport entity (e.g., line or path) is terminated and monitored.

Network Interface (NI)

The point of demarcation on the customer's premises at which CenturyLink's responsibility for the provisioning and maintenance of service ends.

Optical Add-Drop Multiplexer (OADM)

An optical networking NE that allows for the all-optical adding and dropping of wavelength channels in a multiwavelength signal.

Optical Carrier - level N (OC-N)

The optical signal that results from an optical conversion of an STS-N signal.

Optical channel Data Unit - level k (ODUk)

The ODUk is an information structure consisting of the information payload (OPUk) and ODUk related overhead. ODUk capacities for $k = 1$, $k = 2$, $k = 3$ are defined.

Optical channel Payload Unit - level k (OPUk)

The OPUk is the information structure used to adapt client information for transport over an optical channel. It comprises client information together with any overhead needed to perform rate adaptation between the client signal rate and the OPUk payload rate and other OPUk overhead supporting the client signal transport. This overhead is adaptation specific. OPUk capacities for $k=1$, $k=2$, $k=3$ are defined.

Optical channel Transport Unit - level k (OTUk)

The OTUk is the information structure used for transport of an ODUk over one or more optical channel connections. It consists of the optical channel data unit and OTUk related overhead (FEC and overhead for management of an optical channel connection). It is characterized by its frame structure, bit rate, and bandwidth. OTUk capacities for $k = 1$, $k = 2$, $k = 3$ are defined.

Optical Transport Network (OTN)

The transport network defined by the ITU-T consisting of the OPU/ODU, OTU, OCh, OMS, and OTS layers which is composed of a set of optical network elements connected by optical fiber links, able to provide functionality of transport, multiplexing, routing, management, supervision and survivability of optical channels carrying client signals.

Path

The sequence of segments and repeaters providing the connectivity between two points in a network.

Physical Layer entity (PHY)

Within IEEE 802.3, the portion of the Physical Layer that contains the functions that transmit, receive, and manage the encoded signals that are impressed on and recovered from the physical medium.

Point-to-Point

A link connecting two (and only two) points.

Polarization Mode Dispersion (PMD)

A degradation mechanism in fiber whereby optical pulses become smeared in time due to the slightly different refractive index experienced by different polarizations (electric field orientations) in the pulse.

Primary Reference Source (PRS)

Equipment that provides a timing signal whose long-term accuracy is maintained as 1×10^{-11} ; or better, as verified by Universal Coordinated Time, and whose timing signal is used as the basis of reference for the control of other clocks within a network.

Protocol

The rules for communication system operation which must be followed if communication is to be effected; the complete interaction of all possible series of messages across an interface. Protocols may govern portions of a network, types of service, or administrative procedures.

Receiver

A card or circuit that includes a photodetector and converts an incoming signal into an electrical signal.

Reflection

The abrupt change in direction of a light beam at an interface between two dissimilar media so the light beam returns into the media from which it originated.

Regenerator

A unidirectional device that can receive a digital signal and retransmit it in a form in which the amplitude, waveforms, and timing characteristics of the signal are constrained within specified limits.

Remote reconfiguration

The ability of an Optical Network Element (ONE) to modify the cross-connect matrix, on an Optical Tributary basis, with external craftsperson/Operations System (OS) interference. Remote reconfiguration may include channel re-routing due to a craftsperson command on a terminal or an OS command from a remote office.

Route

The physical path established through a network for a particular circuit.

Section

The portion of a transmission facility, including terminating points, between (1) a terminal network element and a regenerator, or (2) two regenerators. A terminating point is the point after signal regeneration at which performance monitoring is (or may be) done.

Serving Wire Center (SWC)

The Wire Center which normally provides service to a customer.

Severely Errored Second (SES)

A second in which the BER is greater than 10^{-3} (note more specific definitions apply to SONET, see GR-253-CORE for further information).

Short Reach (SR)

Optical interfaces referring to optical sections having system loss budgets from 0 dB to 4 or 7 dB (depending on the bit rate).

Singlemode Fiber

A step-index fiber with a very small core diameter which allows transmission of a very high bandwidth and only the lowest order bound mode (which may consist of a pair of orthogonally polarized fields) can propagate at the wavelength of interest.

Splice

The point where two fibers are joined together to make a continuous optical path, or the device or means used to align two fiber ends to create a continuous optical path.

STS Envelope Capacity

Bandwidth within, and aligned to, the STS Frame that carries the STS Synchronous Payload Envelope (SPE). The bandwidth from N STS-1s can be combined to carry an STS-Nc SPE.

Super-Rate Payload

A payload signal that has to be carried by a Contiguous Concatenated Synchronous Transport Signal level N (STS-Nc), STS-1-Xv or STS-3c-Xv Virtual Concatenated Group SPE.

Synchronous

The essential characteristic of time scales or signals such that their corresponding significant instants occur (and are defined to occur) at precisely the same, or multiples of the same, average rate.

Synchronous Optical Network (SONET)

U.S. (ANSI) standard for synchronous data transmission on optical media providing electrical and optical specifications for the physical and higher layers, the first stage of which is at 51.84 Mbps, the Optical Channel - level 1 (OC-1). Other rates defined as OC-N where N=3 through a number not yet firm are possible.

Synchronous Payload

A payload derivable from a network transmission signal by removing integral numbers of bits in every frame (i.e., there are no variable bit stuffing rate adjustments required to fit the payload in the transmission signal).

Synchronous Transport Signal level N (STS-N)

A (functional) module used to build SONET signals. An STS-N has a bit rate of N x 51.84 Mb/s, and may be converted to an OC-N or STS-N electrical interface signal, or multiplexed with other modules to form a higher rate signal (in which case it is referred to as an STS-M).

Threshold Crossing Alert (TCA)

A message generated by a NE and sent to the appropriate OS if, at any time during the accumulation cycle, the current value of a performance monitoring parameter reaches or exceeds its corresponding (settable) threshold value.

Transmitter

Either a card or a circuit that includes a laser or LED, and that transmits an optical signal onto a fiber.

Transparent

In communication systems, that property which allows transmission of signals without changing the electrical characteristics or coding beyond the specified limits of the system design.

Transponder cards

The input wavelength converting cards on a DWDM system. Accepts 1310 nm band or 1550 nm band signals, and converts them to one of the 1550 nm band signals used by the DWDM system (ITU-T G.694.1 grid standard wavelengths) for transmission.

Undefined bits/bytes

Those locations within the signal that do not have a function or value assigned to them. The receiver is required to ignore the value of these bits/bytes (except for BIP-8 calculation/verification).

Wavelength

The distance an electromagnetic wave travels in the time it takes to oscillate through a complete cycle. Wavelengths of light are measured in nanometers or microns.

Wavelength Conversion

The generic process of changing the nominal operating wavelength of an optical tributary. Wavelength conversion can be achieved via Optical-Electrical-Optical (OEO) conversion or all optically without OEO conversion. Wavelength conversion could result in changes in other optical characteristics (such as the spectral width) of the signal.

Wavelength Division Multiplexer (WDM)

Passive fiber optic branching components that combine or separate optical channels on the basis of wavelength.

Wavelength Division Multiplexing (WDM)

A technology that allows two or more optical signals with different wavelengths to be simultaneously transmitted in the same direction over one fiber, and then separated by wavelength at the distant end.

Wavelength Selective Switch (WSS)

A WDM component that can take in all wavelengths from a WDM Carrier into its Line side port and send any combination of the input wavelengths to any outgoing WSS drop port on the component. Functionally an outgoing port can serve as a Wavelength Cross-Connects (WXC) port that allows interconnections between WDM links.

Wire Center (WC)

A building in which one or more Central Offices, used for the provision of local exchange services, are located.

7. References

7.1 American National Standards Institute Documents

ANSI INCITS 326-1999	<i>Information Technology - Fibre Channel - Low-Cost 10-km Optical 1063-MBaud Interface (100-SM-LC-L)</i>
ANSI INCITS 349-2001	<i>Information Technology - Fibre Channel - Single-Byte-2 (FC-SB-2)</i>
ANSI INCITS 352-2002	<i>American National Standard for Information Technology - Fibre Channel - Physical Interfaces (FC-PI)</i>
ANSI INCITS 364-2003	<i>Information Technology - Fibre Channel - 10 Gigabit (10GFC)</i>
ANSI INCITS 373-2003	<i>Information Technology - Fibre Channel - Framing and Signaling (FC-FS)</i>
ANSI INCITS 374-2003	<i>Information technology - Fibre Channel - Single-Byte Command Code Sets Mapping Protocol - 3 (FC-SB-3)</i>
ANSI INCITS 404-2006	<i>American National Standard for Information Technology - Fibre Channel - Physical Interfaces-2 (FC-PI-2)</i>
ANSI INCITS 424-2007	<i>Fibre Channel - Framing and Signaling-2 (FC-FS-2)</i>
ANSI T1.105-2001	<i>Synchronous Optical Network (SONET) - Basic Description including Multiplex Structure, Rates, and Formats</i>
ANSI T1.105.03-2003(R2008)	<i>Synchronous Optical Network (SONET) - Jitter and Wander at Network and Equipment Interfaces</i>
ANSI T1.105.06-2002(R2007)	<i>Telecommunications - Synchronous Optical Network (SONET): Physical Layer Specifications</i>
ANSI T1.223-2004	<i>Structure and Representation of Network Channel (NC) and Network Channel Interface (NCI) Codes for information exchanges</i>
ANSI T1.231-2003(R2007)	<i>Layer 1 In-Service Digital Transmission Performance Monitoring</i>

ANSI/TIA-526-7-2008	<i>OFSTP-7 Measurement of Optical Power Loss of Installed Single-Mode Fiber Cable Plant</i>
ANSI/TIA/EIA-570-B-2010	<i>Residential Telecommunications Cabling Standard</i>
ANSI/TIA/EIA-604-3-B-2004	<i>FOCIS (Fiber Optic Connector Intermateability Standard) 3, Type SC and SC-APC</i>
ANSI/TIA/EIA-604-4-B-2004	<i>FOCIS (Fiber Optic Connector Intermateability Standard) 4, Type FC and FC-APC</i>
ANSI/TIA/EIA-604-10-A-2002	<i>FOCIS (Fiber Optic Connector Intermateability Standard) 10, Type LC</i>
ANSI/TIA/EIA-758-A-2004	<i>Customer-Owned Outside Plant Telecommunications Cabling Standard</i>
ATIS-0900.105.02-2007	<i>Synchronous Optical Network (SONET) - Payload Mappings</i>

7.2 Telcordia Documents

GR-20-CORE	<i>Generic Requirements for Optical Fiber and Optical Fiber Cable</i>
GR-253-CORE	<i>Synchronous Optical Network (SONET) Transport Systems: Common Generic Criteria</i>
GR-499-CORE	<i>Transport Systems Generic Requirements (TSGR): Common Requirements</i>
GR-1377-CORE	<i>SONET OC-192 Transport System Generic Criteria</i>
GR-2918-CORE	<i>DWDM Network Transport Systems with Digital Tributaries for Use in Metropolitan Area Applications: Common Generic Criteria</i>
GR-2979-CORE	<i>Common Generic Requirements for Optical Add-Drop Multiplexers (OADMs) and Optical Terminal Multiplexers (OTMs)</i>
GR-3009-CORE	<i>Optical Cross-Connect Generic Requirements</i>
SR-307	<i>COMMON LANGUAGE NC/NCI Dictionary</i>

7.3 IBM Redbooks®

SA24-7172-06	<i>System z Fiber Channel Connection (FICON) I/O Interface Physical Layer</i>
--------------	---

SG24-5445-00 *FICON (FCV Mode) Planning Guide*

SG24-6266-01 *FICON Native Implementation and Reference Guide*

7.4 International Telecommunication Union - Telecommunication Standardization Sector (ITU-T) Recommendations

G.652 *Characteristics of a single-mode optical fibre and cable*

G.693 *Optical interfaces for intra-office systems*

G.694.1 *Spectral grids for WDM applications: DWDM frequency grid*

G.695 *Optical interfaces for coarse wavelength division multiplexing applications*

G.709 *Interfaces for the Optical Transport Network (OTN)*

G.825 *The control of jitter and wander within digital networks which are based on the synchronous digital hierarchy (SDH)*

G.872 *Architecture of optical transport networks*

G.959.1 *Optical transport network physical layer interfaces*

G.7041 *Generic framing procedure (GFP)*

G.8251 *The control of jitter and wander within the optical transport network (OTN)*

G.Sup43 *Transport of IEEE 10GBASE-R in optical transport networks (OTN)*

7.5 CenturyLink Technical Publications

PUB 77344 *DIVERSITY AND AVOIDANCE, Issue B, September 2001*

PUB 77346 *Synchronous Service Transport (SST), Issue U, November 2012*

PUB 77368 *CUSTOMER PREMISES ENVIRONMENTAL SPECIFICATIONS AND INSTALLATION GUIDE, Issue F, July 2009*

PUB 77386 *Interconnection and Collocation for Transport and Switched Unbundled Network Elements and Finished Services, Issue N, February 2011*

PUB 77419 *SPECIFICATIONS FOR THE PLACEMENT OF QWEST EQUIPMENT IN CUSTOMER-OWNED OUTDOOR CABINETS, Issue B, June 2011*

7.6 Institute of Electrical and Electronics Engineers Documents

- IEEE 802.1Q-2005 *IEEE Standard for Local and metropolitan area networks – Virtual Bridged Local Area Networks*
- IEEE 802.3-2008 *IEEE Standard for Information technology – Telecommunications and information exchange between systems – Local and metropolitan area networks – Specific requirements – Part 3: Carrier Sense Multiple Access with Collision Detection (CSMA/CD) access method and Physical Layer specifications*
- IEEE 802.3ba-2010 *Amendment 4: Media Access Control Parameters, Physical Layers, and Management Parameters for 40 Gb/s and 100 Gb/s Operation*

7.7 International Organization for Standardization/International Electrotechnical Commission Publications

- ISO/IEC 11801: 2002+A1:2008 *Information technology – Generic cabling for customer premises*

7.8 Ordering Information

All documents are subject to change and their citation in this document reflects the most current information available at the time of printing. Readers are advised to check status and availability of all documents.

Those who are not CenturyLink employees may obtain;

- ANSI documents and ISO/IEC publications from:

American National Standards Institute
Attn: Customer Service
11 West 42nd Street
New York, NY 10036
Phone: (212) 642-4900
Fax: (212) 302-1286
Web: <http://www.ansi.org/>

ANSI has a catalog available which describes their publications.

More detailed information about the Fibre Channel standards including FICON can be obtained from the following Web sites:

<http://www.t10.org>
<http://www.t11.org/index.html>

- Telcordia documents from:

Telcordia Customer Relations
8 Corporate Place, PYA 3A-184
Piscataway, NJ 08854-4156
Fax: (732) 699-2559
Phone: (800) 521-CORE (2673) (U.S. and Canada)
Phone: (908) 699-5800 (Others)
Web: <http://www.telcordia.com>

- IBM Redbooks may be obtained from:

International Business Machines
Phone: (800) 879-2755
Fax: (800) 445-9269
Web: <http://www.redbooks.ibm.com/>

- ITU-T Recommendations from:

International Telecommunications Union
General Secretariat
Place des Nations, CH-1211
Geneva 20, Switzerland
Web: <http://www.itu.int/home/>

- CenturyLink Technical Publications from:

<http://www.qwest.com/techpub/>

- IEEE documents from:

Institute of Electrical and Electronics Engineers
445 Hoes Lane
P.O. Box 1331
Piscataway, NJ 08855
Web: <http://www.ieee.org/portal/site>

7.9 Trademarks

CenturyLink	Registered Trademark of CenturyLink, Inc.
IEEE	Registered Trademark of the Institute of Electrical and Electronics Engineers, Inc.
FICON	Registered Trademark of International Business Machines Corporation
IBM	Registered Trademark of International Business Machines Corporation
Redbooks	Registered Trademark of International Business Machines Corporation
S/390	Registered Trademark of International Business Machines Corporation
zSeries	Registered Trademark of International Business Machines Corporation