

**Qwest Corporation d/b/a CenturyLink QC
Private Line Transport Services
Catalog**

State of North Dakota
Effective: 6-25-2011

PREFACE PAGE 1
Release 2

Effective August 1, 1999, this Catalog canceled and replaced the Private Line Transport Services Price Schedule, that became effective December 5, 1994, and all of its subsequent revisions. This was in accordance with Senate Bill 2420, which was approved and passed during the 1999 North Dakota legislative session.

**Qwest Corporation d/b/a CenturyLink QC
Private Line Transport Services
Catalog**

State of North Dakota
Effective: 6-25-2011

PREFACE PAGE 2
Release 1

Pursuant to commitments made with wholesale customers in the Settlement Agreement entered into on November 6, 2010, as amended, between CenturyLink, Inc. (CenturyLink), Qwest Communications International, Inc. (QCI), and Integra Telecom, Inc. (Integra) in the context of CenturyLink's merger with QCI, [Qwest/CenturyLink] hereby provides notice of:

Wholesale (Interexchange Carrier, Local Exchange Carrier and Commercial Mobile Radio Service Provider) term agreements for Private Line Transport Services will be extended by 12 months beyond the expiration date of the then existing term, unless the wholesale customer opts out of this extension.

(N)

(N)

**Qwest Corporation d/b/a CenturyLink QC
Private Line Transport Services
Catalog**

(C)

State of North Dakota
Effective: 8-8-2011

TITLE PAGE
Release 2

TERMS, CONDITIONS, RATES AND CHARGES

Applicable to IntraLATA/Intrastate

Private Line Transport Services

For Customers Within the Operating Territory of

Qwest Corporation d/b/a CenturyLink QC

(C)

Whether offered under that name, or the trade or brand name CenturyLink

(N)

in the State of

NORTH DAKOTA

ADOPTION NOTICE

(N)

Effective April 1, 2011, Qwest Corporation registered the fictitious name CenturyLink QC. Effective August 8, 2011, Qwest Corporation began operating under the name CenturyLink QC. As such, Qwest Corporation d/b/a CenturyLink QC hereby adopts, ratifies and makes its own, in every respect as if the same had been originally filed by it, all schedules, rules, notices, concurrences, schedule agreements, divisions, authorities or other instruments whatsoever, filed with the North Dakota Public Service Commission, State of North Dakota, by or adopted by Qwest Corporation.

By this notice, Qwest Corporation d/b/a CenturyLink QC also adopts and ratifies all supplements or amendments to any of the above schedules, etc., which Qwest Corporation has heretofore filed with said Commission.

(N)

Qwest Corporation
Private Line Transport Services
Catalog

State of North Dakota
Effective: 3-9-2001

SECTION 1
Index Page 1
Release 1

1. APPLICATION AND REFERENCE

SUBJECT	PAGE
Application of Catalog	1
Explanation of Abbreviations	17
Explanation of Change Symbols	16
Catalog Format	14
Reference to Other Catalogs or Tariffs	20
Reference to Other Publications	25
Reference to Technical Publications	21
Subject Index	8
Table of Contents	2
Trademarks, Service Marks and Trade Names	20

Qwest Corporation d/b/a CenturyLink QC
Private Line Transport Services
Catalog

(C)

State of North Dakota
Effective: 8-8-2011

SECTION 1
Page 1
Release 2

1. APPLICATION AND REFERENCE

1.1 APPLICATION OF CATALOG

This Catalog contains the terms and conditions and price lists applicable to Private Line Transport Services, furnished by Qwest Corporation, d/b/a CenturyLink QC hereinafter referred to as the Company, between and among points within the State of North Dakota. The regulated services offered herein by Qwest Corporation, d/b/a CenturyLink QC, whether under that name, or the trade or brand name CenturyLink, are subject to the terms and conditions of this Catalog.

(C)

(C)

The procedures which will be followed by the Company in rendering service are set forth in Section 2, General Regulations, and Section 3, Rate Regulations, following, and 2.6, which includes definitions explaining phrases and terms used.

Unless otherwise specified, the terms and conditions and price lists are applicable to intraLATA/Intrastate Private Line Transport Services furnished by the Company or by the Company in conjunction with another connecting Company. The provision of such services by the Company, as set forth in this Catalog, does not constitute a joint undertaking with the customer for the furnishing of any service.

Prices for Private Line Transport Service will be above cost.

The Company will make every reasonable effort to provide the services delineated in Section 5, following, upon reasonable notice of request for the service from the customer. All rates and charges shown in this Catalog provide for the furnishing of service where suitable facilities are available. Where special construction of channel facilities is necessary, special construction charges may apply. Terms and conditions governing the determination of charges for special construction in connection with Private Line Transport Services furnished by the Company are found in 4.1.6, Special Construction.

Each page of the Catalog bears the date upon which it became effective.

The Table of Contents contains a complete list of all effective Private Line Transport Services offerings and includes the titles, page numbers and other information necessary for their identification.

Qwest Corporation
Private Line Transport Services
Catalog

State of North Dakota
Effective: 04-19-2017

SECTION 1
Page 2
Release 2

1. APPLICATION AND REFERENCE

1.2 TABLE OF CONTENTS

		PAGE	
1. APPLICATION AND REFERENCE			
1.1	APPLICATION OF CATALOG	1	
1.2	TABLE OF CONTENTS	2	
1.3	SUBJECT INDEX	8	
1.4	CATALOG FORMAT	14	
1.4.1	LOCATION OF MATERIAL	14	
1.4.2	OUTLINE STRUCTURE.....	14	
1.4.3	RATE TABLES	15	
1.4.4	RESERVED FOR FUTURE USE.....	15	(T)
1.5	EXPLANATION OF CHANGE SYMBOLS	16	
1.6	EXPLANATION OF ABBREVIATIONS.....	17	
1.7	TRADEMARKS, SERVICE MARKS AND TRADE NAMES	20	
1.8	REFERENCE TO OTHER CATALOGS OR TARIFFS	20	
1.9	REFERENCE TO TECHNICAL PUBLICATIONS	21	
1.10	REFERENCE TO OTHER PUBLICATIONS.....	25	
2. GENERAL REGULATIONS			
2.1	UNDERTAKING OF THE COMPANY	1	
2.1.1	SCOPE.....	1	
2.1.2	LIMITATIONS	1	
2.1.3	LIABILITY	2	
2.1.4	INSTALLATION AND TERMINATION OF SERVICES.....	3	
2.1.5	PROVISION OF SERVICES	4	
2.1.6	CHANGES AND SUBSTITUTIONS.....	4	
2.1.7	REFUSAL AND DISCONTINUANCE OF SERVICE	5	
2.1.8	LIMITATION OF USE OF METALLIC FACILITIES	5	
2.1.9	NOTIFICATION OF SERVICE-AFFECTING ACTIVITIES.....	5	
2.1.10	COORDINATION WITH RESPECT TO NETWORK CONTINGENCIES	6	
2.1.11	PROVISION AND OWNERSHIP OF TELEPHONE NUMBERS.....	6	
2.1.12	SPECIAL TAXES, FEES AND CHARGES.....	6	

NOTICE
THE INFORMATION CONTAINED IN THIS DOCUMENT IS SUBJECT TO CHANGE.

Qwest Corporation
Private Line Transport Services
Catalog

State of North Dakota
Effective: 4-20-2009

SECTION 1
Page 3
Release 2

1. APPLICATION AND REFERENCE

1.2 TABLE OF CONTENTS (Cont'd)

	PAGE
2.2 USE	7
2.2.1 INTERFERENCE OR IMPAIRMENT	7
2.2.2 UNLAWFUL USE.....	7
2.3 OBLIGATIONS OF THE CUSTOMER.....	8
2.3.1 ORDERING, PAYMENT AND COMPLIANCE WITH TERMS AND CONDITIONS	8
2.3.2 DAMAGES	9
2.3.3 OWNERSHIP OF FACILITIES	9
2.3.4 EQUIPMENT SPACE AND POWER	9
2.3.5 HAZARDOUS AND EXPLOSIVE ENVIRONMENTS	10
2.3.6 AVAILABILITY FOR TESTING	10
2.3.7 REFERENCES TO THE COMPANY	10
2.3.8 CLAIMS AND DEMANDS FOR DAMAGES.....	10
2.3.9 COORDINATION WITH RESPECT TO NETWORK CONTINGENCIES	11
2.3.10 BUSINESS HOURS	11
2.4 PAYMENT ARRANGEMENTS AND CREDIT ALLOWANCES.....	12
2.4.1 END USER ACCOUNTS	12
2.4.2 CARRIER ACCOUNTS	16
2.4.3 CANCELLATION OF AN ORDER FOR SERVICE.....	22
2.4.4 CREDIT ALLOWANCE FOR SERVICE INTERRUPTIONS	22
2.4.5 ORDERING, RATING AND BILLING OF PRIVATE LINE TRANSPORT WHERE MORE THAN ONE EXCHANGE TELEPHONE COMPANY IS INVOLVED	29
2.4.6 TERMINATION LIABILITY/WAIVER POLICY	33
2.5 CONNECTIONS.....	35
2.5.1 GENERAL.....	35
2.6 DEFINITIONS	36
2.12 NATURAL DISASTER RELIEF FOR CUSTOMERS.....	50

(N)

**Qwest Corporation
Private Line Transport Services
Catalog**

State of North Dakota
Effective: 11-30-2006

SECTION 1
Page 4
Release 2

1. APPLICATION AND REFERENCE

1.2 TABLE OF CONTENTS (Cont'd)

	PAGE	
3. RATE CONDITIONS		
3.1	GENERAL	1
3.2	TYPES OF CHARGES	1
3.2.1	RECURRING RATES	1
3.2.2	NONRECURRING CHARGES	1
3.2.3	CUSTOM SERVICE ARRANGEMENT.....	10
3.2.4	RATE STABILIZED AND DISCOUNT PRICING	10
3.2.5	ANALOG PRIVATE LINE TRANSPORT SERVICE UPGRADES.....	21
3.3	MINIMUM BILLING PERIOD AND FRACTIONAL RATES.....	22
3.4	MILEAGE MEASUREMENT.....	23
3.5	RESERVED FOR FUTURE USE	24
3.6	COMPETITIVE RESPONSE.....	24

**Qwest Corporation
Private Line Transport Services
Catalog**

State of North Dakota
Effective: 3-9-2001

SECTION 1
Page 5
Release 1

1. APPLICATION AND REFERENCE

1.2 TABLE OF CONTENTS (Cont'd)

		PAGE
4. ORDER MODIFICATIONS AND MISCELLANEOUS CHARGES		
4.1	GENERAL	1
4.1.1	SERVICE DATE CHANGE	1
4.1.2	DESIGN CHANGE.....	2
4.1.3	CANCELLATION OF APPLICATION FOR SERVICE.....	3
4.1.4	EXPEDITE	7
4.1.5	DESIGN LAYOUT REPORT (DLR).....	8
4.1.6	SPECIAL CONSTRUCTION.....	8
4.1.7	MAINTAINING FACILITIES.....	10
4.1.8	MAINTENANCE OF SERVICE	10
4.1.9	PREMISES WORK.....	11
4.1.10	ADDITIONAL ENGINEERING	12
4.1.11	ADDITIONAL LABOR	12
4.1.12	MAINTENANCE OF SERVICE, ADDITIONAL ENGINEERING AND LABOR RATES AND CHARGES	13
4.1.13	ACCEPTANCE TESTING	16
4.1.14	TESTING SERVICES	16
4.1.15	TESTING RATES AND CHARGES.....	18
4.1.16	DISPATCH CHARGE	19
4.2	PROVISION OF PRIVATE LINE TRANSPORT BILLING INFORMATION-CARRIERS	20
4.3	FACILITIES PROTECTION - SPECIAL FACILITIES ROUTING.....	22
4.4	COMMAND A LINK	25
4.5	PROTECTION SERVICE FOR HIGH VOLTAGE ENVIRONMENTS.....	35

**104. OBSOLETE ORDER MODIFICATIONS
AND MISCELLANEOUS CHARGES**

104.5	HIGH VOLTAGE ENVIRONMENT PROTECTION ARRANGEMENT.....	1
-------	--	---

Qwest Corporation d/b/a CenturyLink QC
Private Line Transport Services
Catalog

State of North Dakota
Effective: 12-01-2020

SECTION 1
Page 6
Release 5

1. APPLICATION AND REFERENCE

1.2 TABLE OF CONTENTS (Cont'd)

		PAGE	
5. SERVICES			
5.1	GENERAL	1	
5.1.1	SERVICE TYPES.....	1	
5.1.2	RATE CATEGORIES.....	4	
5.1.3	SERVICE CONFIGURATIONS	6	
5.1.4	FACILITY HUBS.....	10	
5.1.5	SHARED USE.....	11	
5.2	SERVICE DESCRIPTIONS	12	
5.2.1	LOW-SPEED DATA SERVICE - GRANDFATHERED	12	(C)
5.2.2	VOICE GRADE SERVICE - GRANDFATHERED	17	(C)
5.2.4	AUDIO SERVICE - GRANDFATHERED	26	(C)
5.2.5	FOREIGN EXCHANGE SERVICE.....	29	
5.2.6	FOREIGN CENTRAL OFFICE SERVICE.....	32	
5.2.7	EXCHANGE SERVICE EXTENSIONS (NON-PBX)	34	
5.2.8	TELEPHONE ANSWERING SERVICE.....	35	
5.2.9	DIGITAL DATA SERVICE – GRANDFATHERED	38	(C)
5.2.10	DS1 SERVICE.....	43	
5.2.11	DS3 SERVICE.....	63	

105. OBSOLETE SERVICES

105.1	GENERAL	1	
105.2	SERVICE DESCRIPTIONS	1	
105.2.2	VOICE GRADE SERVICE.....	1	
105.2.10	DS1 SERVICE.....	4	
105.15	MISCELLANEOUS SERVICES	5	

ND2020-13

NOTICE
THE INFORMATION CONTAINED IN THIS DOCUMENT IS SUBJECT TO CHANGE.

Qwest Corporation d/b/a CenturyLink QC
Private Line Transport Services
Catalog

State of North Dakota
Effective: 12-01-2020

SECTION 1
Page 7
Release 4

1. APPLICATION AND REFERENCE

1.2 TABLE OF CONTENTS (Cont'd)

		PAGE	
6. RATES AND CHARGES			
6.1	ANALOG AND DIGITAL DATA SERVICE– GRANDFATHERED....	1	(C)
6.1.1	SERVICE PROVISIONING CHARGE.....	1	
6.1.2	NETWORK ACCESS CHANNEL.....	1	
6.1.3	CHANNEL PERFORMANCE.....	2	
6.1.4	TRANSPORT MILEAGE.....	8	
6.1.5	OPTIONAL FEATURES AND FUNCTIONS.....	13	
6.4	RESERVED FOR FUTURE USE	18	
6.5	RESERVED FOR FUTURE USE	19	
6.6	RESERVED FOR FUTURE USE	20	
6.7	RESERVED FOR FUTURE USE	21	
6.8	RESERVED FOR FUTURE USE	22	
6.9	RESERVED FOR FUTURE USE	23	
6.10	DS1 SERVICE	24	
6.11	DS3 SERVICE	80	

Qwest Corporation
Private Line Transport Services
Catalog

State of North Dakota
Effective: 6-3-2005

SECTION 1
Page 8
Release 2

1. APPLICATION AND REFERENCE

1.3 SUBJECT INDEX

SUBJECT	SECTION	
Acceptance Testing	4	
Additional Cooperative Acceptance Testing	4	
Additional Engineering	4	
Rates and Charges	4	
Additional Labor	4	
Other Labor	4	
Rates and Charges	4	
Administrative Charges	3	
Advance Payments	2	
Analog and Digital Data Service	6	(N)
Analog Private Line Transport Service Upgrades	3	
Audio Service.....	5	
Rates and Charges	6	
Availability for Testing	2	
Avoidance	4	
Billing	2	
Billing Disputes.....	2	
Billing Information.....	4	
Bridging	5	
Rates and Charges	6	
Business Hours.....	2	
Cancellation of an Application For Service.....	4	
Carrier Accounts	2	
Central Office Multiplexing.....	5	
Rates and Charges	6	
Changes and Substitutions	2	
Channel Performance		
Rate Regulations	3	
Rates and Charges	6	
Services.....	5	
Clear Channel Capability.....	5	
Rates and Charges	6	

Qwest Corporation
Private Line Transport Services
Catalog

State of North Dakota
Effective: 11-30-2006

SECTION 1
Page 9
Release 2

1. APPLICATION AND REFERENCE

1.3 SUBJECT INDEX (Cont'd)

SUBJECT	SECTION	
Command A Link.....	4	
Rates and Charges	4	
Competitive Response	3	
Conditioning	5	
Rates and Charges	6	
CO Relay	5	
Rates and Charges	6	
Connections	2	
Coordination with Respect to Network Contingencies	2	
Credit Allowance for Service Interruptions.....	2	
Critical Dates	4	
Custom Service Arrangement.....	3	
Damages	2	
Definitions	2	
Deposits	2	
Design Change	4	
Design Layout Report.....	4	
Digital Data Service (DDS)	5	
Rates and Charges	6	
Discount Pricing.....	3	
Dispatch Charge.....	4	
Disputes	2	
Diversity	4	
DS1 Service	5	
Rates and Charges	6	
DS3 Service	5	
Rates and Charges	6	

Qwest Corporation
Private Line Transport Services
Catalog

State of North Dakota
Effective: 9-15-2003

SECTION 1
Page 10
Release 2

1. APPLICATION AND REFERENCE

1.3 SUBJECT INDEX (Cont'd)

SUBJECT	SECTION
End User Accounts.....	2
Equipment Space and Power	2
Exchange Service Extensions (Non-PBX)	5
Rates and Charges	6
Facilities Protection-Special Facilities Routing.....	4
Rates and Charges	4
Facility Hub	5
Foreign Exchange Service	5
Rates and Charges	6
Foreign Central Office Service	5
Rates and Charges	6
Fractional Rates.....	3
Half-Tap.....	5
Hazardous and Explosive Environments.....	2
High Voltage Environment Protection Arrangement.....	104
Hub	5
Installation and Termination of Services.....	2
Interest Rates on Deposits	2
Interference or Impairment	2
Key Arrangement.....	5
Rates and Charges	6
Late Payment Charge	2
Liability	2
Limitations	2
Limitation of Use of Metallic Facilities	2
Low-Speed Data Service	5
Rates and Charges	6

(D)

Qwest Corporation
Private Line Transport Services
Catalog

State of North Dakota
 Effective: 5-2-2016

SECTION 1
 Page 11
 Release 3

1. APPLICATION AND REFERENCE

1.3 SUBJECT INDEX (Cont'd)

SUBJECT	SECTION	
Maintaining Facilities	4	(D)
Maintenance of Service	4	
Rates and Charges	4	
Meet Point Billing	2	
Mileage Measurement	3	(D)
Minimum Billing Period.....	3	
Moves	3	
Natural Disaster Relief For Customers.....	2	
Network Access Channel.....	5	
Rates and Charges	6	
Nonrecurring Charges	3	
Notification of Service Affecting Activities.....	2	
Obligations of the Customer	2	
Obsolete Services	105	
Optional Features and Functions		
Rate Regulations	3	
Rates and Charges	6	
Services.....	5	
Order Modification and Miscellaneous Charges	4	
Obsolete	104	
Ordering, Payment and Compliance with Terms and Conditions	2	
Ordering, Rating and Billing of Private Line Transport Where	2	
More than One Exchange Telephone Company is Involved (Meet Point Billing)		
Other Labor	4	
Overtime	2	
Overtime Installation.....	4	
Ownership of Facilities.....	2	

Qwest Corporation
Private Line Transport Services
Catalog

State of North Dakota
Effective: 5-10-2004

SECTION 1
Page 12
Release 2

1. APPLICATION AND REFERENCE

1.3 SUBJECT INDEX (Cont'd)

SUBJECT	SECTION
Payment Arrangements and Credit Allowances	2
Premium Time.....	2
Premises Work	4
Provision and Ownership of Telephone Numbers	2
Provision of Private Line Transport Billing Information - Carriers	4
Provision of Services.....	2
Protection Service for High Voltage Environments.....	4
Rate Categories	5
Rate Regulations	3
Rate Stabilized Pricing	3
Rates and Charges	6
Recurring Rates.....	3
Reestablishment of Service Following Fire, Flood, or other Occurrence	3
References to the Company	2
Refusal and Discontinuance of Service.....	2
Repair of Facilities	4
Rollover	3
Scope	2
Secondary Channel.....	5
Rates and Charges	6
Service Configurations	5
Multipoint Service.....	5
Two-Point Service.....	5
Service Date Change	4
Service Guarantee - Provisioning.....	3
Service Guarantee - Repair	2
Service Provisioning.....	3
Service Rearrangement Charge.....	5
Service Rearrangements	3
Service Types.....	5
Services.....	5
Shared Use	5
Special Construction.....	4
Special Taxes, Fees and Charges	2

(D)

Qwest Corporation
Private Line Transport Services
Catalog

State of North Dakota
Effective: 12-1-2001

SECTION 1
Page 13
Release 2

1. APPLICATION AND REFERENCE

1.3 SUBJECT INDEX (Cont'd)

SUBJECT	SECTION	
Telecommunications Service Priority	2	
Telephone Answering Service	5	
Rates and Charges	6	
Telephone Numbers, Provision and Ownership of	2	
Temporary Surrender of a Service	2	
Termination Liability/Waiver Policy	2	
Testing Services	4	
Additional Cooperative Acceptance Testing	4	
Nonscheduled Testings	4	
Transfer Arrangement	5	
Transfer or Assignment of Service.....	2	
Transport Mileage		
Rate Regulations	3	
Rates and Charges	6	
Services.....	5	
Types of Charges.....	3	
Undertaking of the Company.....	2	
Unlawful Use	2	
Upgrades	3	
Use.....	2	
Voice Grade Service.....	5,105	(C)
Rates and Charges	6	

**Qwest Corporation
Private Line Transport Services
Catalog**

State of North Dakota
Effective: 3-9-2001

SECTION 1
Page 14
Release 1

1. APPLICATION AND REFERENCE

1.4 CATALOG FORMAT

1.4.1 LOCATION OF MATERIAL

1. Section 1 provides the following for all of the sections in this Catalog:
 - Subject Index - an alphabetical listing to find the desired section.
 - Table of Contents - A numerical listing to find the desired section and page.
2. Each individual section in the Catalog provides a Subject Index for the material located within that section.
3. Obsolete Service Offerings

Obsolete service offerings are identified in the Catalog by adding 100 to the current section number, i.e., obsolete items from Section 5, Services, would be found in Section 105, Obsolete Services. This section is then filed behind Section 5.

1.4.2 OUTLINE STRUCTURE

This document uses nine levels of indentations referred to as Tariff Information Management (TIM) Codes, as outlined below:

LEVEL	APPLICATION	EXAMPLE
1	Section Heading	2. GENERAL REGULATIONS
2	Sub Heading	2.5 CONNECTIONS
3	Sub Heading	2.5.1 GENERAL
4	Sub Heading/Text	A. Text
5	Sub Heading/Text	1. Text
6	Sub Heading/Text	a. Text
7	Sub Heading/Text	(1) Text
8	Sub Heading/Text	(a) Text
9	Footnotes	[1] Text

Qwest Corporation
Private Line Transport Services
Catalog

State of North Dakota
Effective: 04-19-2017

SECTION 1
Page 15
Release 2

1. APPLICATION AND REFERENCE

1.4 CATALOG FORMAT (Cont'd)

1.4.3 RATE TABLES

Within rate tables, four types of entries are allowed:

- Rate Amount

The rate amount indicates the dollar value associated with the service.

- A dash "-"

The dash indicates that there is no rate for the service or that a rate amount is not applicable under the specific column header.

- A footnote designator "[1]"

The footnote designator indicates that further information is contained in a footnote.

- ICB

The acronym "ICB" indicates that the product/service is rated on an individual case basis.

1.4.4 RESERVED FOR FUTURE USE

(T)

(D)

(D)

Qwest Corporation
Private Line Transport Services
Catalog

State of North Dakota
Effective: 3-9-2001

SECTION 1
Page 16
Release 1

1. APPLICATION AND REFERENCE

1.5 EXPLANATION OF CHANGE SYMBOLS

- (C) - To signify changed term or condition
- (D) - To signify discontinued material
- (I) - To signify rate increase
- (M) - To signify material moved from or to another part of the Catalog with no change, unless there is another change symbol present
- (N) - To signify new material
- (R) - To signify rate reduction
- (T) - To signify a change in text but no change in rate, term or condition

Qwest Corporation
Private Line Transport Services
Catalog

State of North Dakota
Effective: 6-3-2005

SECTION 1
Page 17
Release 2

1. APPLICATION AND REFERENCE

1.6 EXPLANATION OF ABBREVIATIONS

ac	- Alternating current	
ACAT	- Additional Cooperative Testing	
ACD	- Automatic Call Distributor	
AIOD	- Automatic Identification of Outward Dialing	
AMA	- Automatic Message Accounting	
AML	- Actual Measured Loss	
AST	- Automatic Scheduled Testing	
Blvd.	- Boulevard	
bps	- Bits per second	
CCITT	- The International Telegraph and Telephone Consultative Committee	
C.F.R.	- Code of Federal Regulations	
CI	- Channel Interface	
CNCC	- Customer Network Control Center	
Co.	- Company	
CO	- Central Office	
COCTX	- Central Office Centrex	
CP	- Channel Performance	(N)
CPE	- Customer Provided Equipment	
cps	- Cycles per second	
CST	- Cooperative Scheduled Testing	
Ctx	- Centrex	
dB	- Decibel	
dBm0	- Decibel Reference to 0dB	
dBrnC	- Decibel Reference Noise C-Message Weighting	
dBrnC0	- Decibel Reference Noise C-Message Weighted 0	
dBv	- Decibel(s) Relative to 1 Volt (Reference)	
dBvl	- Decibel(s) Relating to 1 Volt (Reference)	
dc	- Direct current	
D.C.	- District of Columbia	
DDS	- Digital Data Service	(N)
<i>DID</i>	- Direct Inward Dialing	
DLR	- Design Layout Report	

Qwest Corporation
Private Line Transport Services
Catalog

State of North Dakota
Effective: 04-19-2017

SECTION 1
Page 18
Release 3

1. APPLICATION AND REFERENCE

1.6 EXPLANATION OF ABBREVIATIONS (Cont'd)

E.	- East
EDD	- Envelope Delay Distortion
e.g.	- For example
EIA	- Electronics Industry Association
ELEPL	- Equal Level Echo Path Loss
EML	- Expected Measured Loss
EPL	- Echo Path Loss
EPSCS	- Enhanced Private Switched Communication Service
ERL	- Echo Return Loss
ESE	- Exchange Service Extension
ESS	- Electronic Switching System
etc.	- Etcetera
ESSX	- Electronic Switching System Exchange
f	- Frequency
F.C.C.	- Federal Communications Commission
FCO	- Foreign Central Office
(D)	
Ft.	- Feet
FX	- Foreign Exchange
GMT	- Greenwich Mean Time
GPR	- Ground Potential Rise
H	- Horizontal
Hz	- Hertz
IC	- Interexchange Carrier
ICB	- Individual Case Basis
ICL	- Inserted Connection Loss
i.e.	- That is
IMP ATTN	- Improved Attenuation
Inc.	- Incorporated
Int. Bdry	- International Boundary
Intelsat	- International Telecommunications Satellite Organization
IP	- Interconnection Point
kbit/s	- Kilobits per second
kHz	- Kilohertz
LATA	- Local Access and Transport Area
mA	- Milliamperes
Mbit/s	- Megabits per second
mcs	- Microseconds
MHz	- Megahertz

Qwest Corporation
Private Line Transport Services
Catalog

State of North Dakota
Effective: 04-19-2017

SECTION 1
Page 19
Release 3

1. APPLICATION AND REFERENCE

1.6 EXPLANATION OF ABBREVIATIONS (Cont'd)

MST	-	Manual Scheduled Testing
MTS	-	Message Telecommunications Service
N.	-	North
NA	-	Not Applicable
NAC	-	Network Access Channel
No.	-	Number
NRC	-	Nonrecurring Charge
NST	-	Nonscheduled Testing
NTS	-	Non-Traffic Sensitive
OCC	-	Other Common Carrier
OFX	-	Obsolete Foreign Exchange
OTPL	-	Zero Transmission Level Point
PBX	-	Private Branch Exchange
PCM	-	Pulse Code Modulation
PI	-	Priority Installation
PL	-	Private Line
PLAR	-	Private Line Automatic Ringdown
P.O.	-	Post Office
POT	-	Point of Termination
PR	-	Priority Restoration
rms	-	root-mean-square
S.	-	South
SP	-	Service Provisioning
SRL	-	Singing Return Loss
SWC	-	Serving Wire Center
TAS	-	Telephone Answering Service
TIM	-	Tariff Information Management
TLP	-	Transmission Level Point
TSP	-	Telecommunications Service Priority
U.S.	-	United States
USASCII	-	U.S. American Standard Code For Information Interexchange
V	-	Vertical
VG	-	Voice Grade
V & H	-	Vertical & Horizontal
W.	-	West

(D)

**Qwest Corporation d/b/a CenturyLink QC
Private Line Transport Services
Catalog**

(C)

State of North Dakota
Effective: 8-8-2011

SECTION 1
Page 20
Release 3

1. APPLICATION AND REFERENCE

1.7 TRADEMARKS, SERVICE MARKS AND TRADE NAMES

The following list of trade names, trademarks and/or service marks which may be used for services offered in this Catalog are owned by CenturyLink, Inc. or a subsidiary of CenturyLink, Inc. and are used by the Company with express permission. Trademark and service mark designations will not be listed hereafter in the Catalog. However, the laws regarding trademarks and service marks are applicable.

(N)

Trade names, trademarks and service marks that are owned by CenturyLink, Inc. or a subsidiary of CenturyLink, Inc. cannot be used by another party without authorization.

CENTURYLINK

CENTURYLINK™

CENTURYLINKSM

(N)

Catalog service names which are preceded by QWEST® or “Qwest,” and Catalog services which include “Qwest” as a part of the service marked or trademarked product name, may also be marketed and/or billed under the trade or brand name CenturyLink, or may be marketed and/or billed without any trade or brand name.

(C)

MARK

DID®

DIGICOM®

(C)

1.8 REFERENCE TO OTHER CATALOGS OR TARIFFS

Whenever reference is made in this Catalog to other tariffs, price schedule or catalogs of the Company, the reference is to the tariffs or catalogs in force as of the effective date of this Catalog, and to amendments thereto and successive issues thereof.

Qwest Corporation
Private Line Transport Services
Catalog

State of North Dakota
Effective: 10-1-2001

SECTION 1
Page 21
Release 2

1. APPLICATION AND REFERENCE

1.9 REFERENCE TO TECHNICAL PUBLICATIONS

All service installed after the original effective date of this Catalog must conform to the transmission specification standards contained in this Catalog or in the following Technical References.

- A. The following technical publications may be obtained from Bell Communications Research, Inc., Distribution Storage Center, 60 New England Ave., Piscataway, NJ 08854-4196:

TITLE	PUBLICATION NUMBER	
Ordering and Billing Forum-Multiple Exchange Carrier Access Billing (MECAB)	ATIS/OBF-MECAB	(T) (T) (D)
Ordering and Billing Forum-Multiple Exchange Carrier Ordering and Design Guidelines (MECOD)	ATIS/OBF-MECOD	(T)
Transport Systems Generic Requirements	FR-NWT-000440	(D)
Industry Support Interface (ISI) General Overview	SR-STS-000284	(D)
Telecommunications Transmission Engineering Textbook-Volume 3: Network and Services, Third Edition	ST-TEC-000053	(D) (D)

Qwest Corporation
Private Line Transport Services
Catalog

State of North Dakota
Effective: 10-1-2001

SECTION 1
Page 22
Release 2

1. APPLICATION AND REFERENCE

1.9 REFERENCE TO TECHNICAL PUBLICATIONS

A. (Cont'd)

TITLE	PUBLICATION NUMBER	
High Capacity Digital Special Access Service - Transmission Parameter Limits and Interface Combinations	TR-INS-000342	
Metallic and Telegraph Grade Special Access Service Transmission Parameter Limits and Interface Combinations	TR-NPL-000036	(D)
High Capacity Digital Service (1.544) Interface Requirements for End Users	TR-NPL-000054	(D)
Voice Grade Special Access Service Transmission Parameter Limits and Interface Combinations	TR-NPL-000335	(D)
Program Audio Special Access and Local Channel Services	TR-NPL-000337	(D)
IntraLATA Voice Grade Private Line Service - Transmission Parameter Limits and Interface Combinations	TR-NWT-000965	(D)
Asynchronous Digital Multiplexes Requirements and Objectives	TR-TSY-000009	(D)

Qwest Corporation
Private Line Transport Services
Catalog

State of North Dakota
Effective: 9-15-2003

SECTION 1
Page 23
Release 3

1. APPLICATION AND REFERENCE

1.9 REFERENCE TO TECHNICAL PUBLICATIONS (Cont'd)

- B. The following Company Technical publications are referenced in this Catalog and may be viewed at <http://www.qwest.com/techpub>.

TITLE	PUBLICATION NUMBER
Low Speed Data, Telegraph And Direct Current Services	77307
Audio Service	77308
Private Line Voice Grade Analog Channels for Access Service	77310
Analog Channels for Non-Access Services	77311
Digital Data Service Transmission Parameter Limits and Interface Combinations	77312

(D)

**Qwest Corporation
Private Line Transport Services
Catalog**

State of North Dakota
Effective: 5-10-2004

SECTION 1
Page 24
Release 3

1. APPLICATION AND REFERENCE

1.9 REFERENCE TO TECHNICAL PUBLICATIONS

B. (Cont'd)

TITLE	PUBLICATION NUMBER
Special High Voltage Protection	77321
DS1 Clear Channel Capability	77323
Diversity and Avoidance	77344
1.544 Mbps Channel Interfaces Technical Specifications for Network Channel Interface Codes, Describing Electrical Interfaces at Customer Premises and Qwest Corporation Central Offices	77375

(D)

Qwest Corporation
Private Line Transport Services
Catalog

State of North Dakota
Effective: 5-1-2015

SECTION 1
Page 25
Release 3

1. APPLICATION AND REFERENCE

1.10 REFERENCE TO OTHER PUBLICATIONS

- A. The following publications are available for inspection in the Public Reference Room of the Tariff Division at the main building of the Federal Communications Commission located at 1919 M Street N.W., Washington, DC, and may be obtained from the Commission's commercial contractor:

TITLE

CC Docket No. 83-1145, Phase I Memorandum Opinion and Order
(Including Appendices A, B, and C)
Adopted: May 31, 1985
Released: June 12, 1985

National Exchange Carrier Association Tariff F.C.C. No. 4

CenturyLink Operating Companies
Tariff F.C.C. No. 11

CenturyLink Operating Companies
Tariff F.C.C. No. 12

(T)
—
(T)

- B. The following publication may be obtained by contacting the Company Account Representative:

TITLE

Qwest Corporation Service Interval Guide

Qwest Corporation
Private Line Transport Services
Catalog

State of North Dakota
Effective: 3-9-2001

SECTION 2
Index Page 1
Release 1

2. GENERAL REGULATIONS

SUBJECT	PAGE
Advance Payments	12
Availability for Testing	10
Billing	
Carrier Accounts	18
End User Accounts	12
Billing Disputes	
Carrier Accounts	20
End User Accounts	15
Business Hours	11
Carrier Accounts	16
Changes and Substitutions	4
Connections	35
Coordination with Respect to Network Contingencies	
Obligations of the Customer	11
Undertaking of the Company	6
Credit Allowance for Service Interruptions	22
Damages	9
Definitions	36
Deposits	
Carrier Accounts	16
End User Accounts	12
End User Accounts	12
Equipment Space and Power	9
Hazardous and Explosive Environments	10

Qwest Corporation
Private Line Transport Services
Catalog

State of North Dakota
Effective: 4-20-2009

SECTION 2
Index Page 2
Release 2

2. GENERAL REGULATIONS

SUBJECT	PAGE	
Installation and Termination of Services	3	
Interest Rates on Deposits		
Carrier Accounts	17	
End User Accounts	12	
Interference or Impairment	7	
Late Payment Charge		
Carrier Accounts	19	
End User Accounts	15	
Liability	2	
Limitations	1	
Limitation of Use of Metallic Facilities	5	
Meet Point Billing	29	
Natural Disaster Relief For Customers.....	18	(N)
Notification of Service Affecting Activities	5	
Obligations of the Customer	8	
Ordering, Payment and Compliance with Terms and Conditions	8	
Ordering, Rate and Billing of Private Line Transport Where More than One Exchange Telephone Company is Involved (Meet Point Billing)	29	
Overtime	11	
Ownership of Facilities	9	

Qwest Corporation
Private Line Transport Services
Catalog

State of North Dakota
Effective: 3-9-2001

SECTION 2
Index Page 3
Release 1

2. GENERAL REGULATIONS

SUBJECT	PAGE
Payment Arrangements and Credit Allowances	12
Premium Time	11
Provision and Ownership of Telephone Numbers	6
Provision of Services	4
References to the Company	10
Refusal and Discontinuance of Service	5
Scope	1
Service Guarantee - Repair	25
Special Taxes, Fees and Charges	6
Telecommunications Service Priority	1
Telephone Numbers, Provision and Ownership of	6
Temporary Surrender of a Service	28
Termination Liability/Waiver Policy	33
Transfer or Assignment of Service.....	8
Undertaking of the Company	1
Unlawful Use	7
Use	7

Qwest Corporation
Private Line Transport Services
Catalog

State of North Dakota
Effective: 3-9-2001

SECTION 2
Page 1
Release 1

2. GENERAL REGULATIONS

2.1 UNDERTAKING OF THE COMPANY

2.1.1 SCOPE

- A. Private Line Transport is the furnishing of Company facilities for communication purposes of the customer and end users (jointly referred to as customer) between specified locations. Private Line Transport is provided by means of wire, fiber, radio or any other suitable technology or a combination thereof. Service is furnished 7 days per week, 24 hours per day for a minimum billing period of one month or as defined in 2.4.3, following.
- B. The Company shall be responsible only for the installation, operation and maintenance of the services which it provides, as defined in 2.1.4 and 2.1.5, following.
- C. The Company does not warrant that its facilities and services meet standards other than those set forth in this Catalog and the associated technical references.
- D. The Company will, for maintenance purposes, test its services only to the extent necessary to detect and/or clear troubles.

2.1.2 LIMITATIONS

- A. The installation and restoration of services shall be subject to the regulations set forth in Section 13 of the Access Service Price Schedule concerning the Telecommunications Service Priority (TSP) System.
- B. Subject to compliance with the rules mentioned in A., preceding, where a shortage of channels exists at any time either for temporary or protracted periods, the services offered herein will be provided to customers on a first come, first served basis.
- C. The furnishing of service under this Catalog will require certain physical arrangements of the facilities of the Company and is therefore subject to the availability of such facilities.

Qwest Corporation
Private Line Transport Services
Catalog

State of North Dakota
Effective: 3-9-2001

SECTION 2
Page 2
Release 1

2. GENERAL REGULATIONS

2.1 UNDERTAKING OF THE COMPANY (Cont'd)

2.1.3 LIABILITY

- A. The Company's liability, if any, for its willful misconduct is not limited by this Catalog. With respect to any other claim or suit, by a customer or by any others, for damages associated with the installation, provision, preemption, termination, maintenance, repair or restoration of service, including presubscription, and subject to the provisions of B. through G., following, the Company's liability, if any, shall not exceed an amount equal to the proportionate charge for the service for the period during which the service was affected. This liability shall be in addition to any amounts that may otherwise be due the customer under this Catalog as a Credit Allowance for a Service Interruption as set forth in 2.4.4, following.
- B. The Company shall be indemnified, defended and held harmless by the customer against any claim, loss, or damage arising from use of services offered under this Catalog involving:
 - 1. Claims for libel, slander, invasion of privacy and infringement of copyright arising from the material transmitted over the facilities or the customer's or Interexchange Carrier's (IC) own communications;
 - 2. Claims for infringement of patents arising from combining with, or using in connection with, facilities furnished by the Company, facilities or equipment furnished by the customer or IC;
 - 3. All other claims arising out of any act or omission of the customer or IC in connection with the facilities provided by the Company.
- C. The Company shall not be liable for any act or omission of any customer providing a portion of a service, nor shall the Company for its own act or omission hold liable any customer providing a portion of a service.
- D. The Company does not guarantee or make any warranty with respect to its services when used in an explosive atmosphere. The Company shall be indemnified, defended and held harmless by the customer from any and all claims by any person relating to such customer's use of services so provided.

Qwest Corporation
Private Line Transport Services
Catalog

State of North Dakota
Effective: 3-9-2001

SECTION 2
Page 3
Release 1

2. GENERAL REGULATIONS

2.1 UNDERTAKING OF THE COMPANY

2.1.3 LIABILITY (Cont'd)

- E. The Company is not liable for any defacement of or damage to the premises of a customer resulting from the furnishing of any facilities by the Company on the premises or by the installation or removal when defacement or damage is not the result of negligence of the agents or employees of the Company.
- F. No license under patents (other than the limited license to use) is granted by the Company or shall be implied or arise by estoppel, with respect to any service offered under this Catalog. The Company will defend the customer against claims of patent infringement arising solely from the use by the customer of services offered under this Catalog and will indemnify such customer for any damages awarded based solely on such claims.
- G. The Company's failure to provide or maintain services under this Catalog shall be excused by labor difficulties, governmental orders, civil commotions, criminal actions taken against the Company, acts of God and other circumstances beyond the Company's reasonable control, subject to the Credit Allowance for a Service Interruption as set forth in 2.4.4, following.

2.1.4 INSTALLATION AND TERMINATION OF SERVICES

The services provided under this Catalog, (A) will include any Company facilities to that point where provision is made for termination of the Company's outside distribution network facilities at a suitable location at a customer-designated premises, and (B) will be installed by the Company to such Point of Termination (POT). Each Private Line Transport has only one POT per customer premises. Any additional terminations beyond such POT are the sole responsibility of the customer.

Qwest Corporation
Private Line Transport Services
Catalog

State of North Dakota
Effective: 3-9-2001

SECTION 2
Page 4
Release 1

2. GENERAL REGULATIONS

2.1 UNDERTAKING OF THE COMPANY (Cont'd)

2.1.5 PROVISION OF SERVICES

- A. The services provided to the POT under this Catalog shall be maintained by the Company. The customer may not rearrange, disconnect, remove or attempt to repair or permit others to rearrange, disconnect, remove or attempt to repair any facilities installed by the Company to the POT, except upon the written consent of the Company.

- B. Facilities on the premises of a customer furnished by the Company to the POT, are the property of the Company, whose agents and employees shall have the right to enter said premises at any reasonable hour for the purpose of installing, inspecting or repairing the facilities, or upon termination of the service or channel, for the purpose of removing Company facilities.

2.1.6 CHANGES AND SUBSTITUTIONS

Except as provided for equipment and systems subject to F.C.C. Part 68 regulations at 47 C.F.R. Section 68.110(b), the Company may, where such action is reasonably required in the operation of its business, (A) substitute, change or rearrange any facilities used in providing service under this Catalog, including but not limited to, (1) substitution of different metallic facilities, (2) substitution of carrier or derived facilities for metallic facilities used to provide other than metallic facilities and (3) substitution of metallic facilities for carrier or derived facilities used to provide other than metallic facilities, (B) change minimum protection criteria, (C) change operating or maintenance characteristics of facilities, or (D) change operations or procedures of the Company.

In case of any such substitution, change or rearrangement, the performance characteristics will be within the range as set forth in this Catalog. The Company shall not be responsible if any such substitution, change or rearrangement renders any customer furnished services obsolete or requires modification or alteration thereof or otherwise affects their use or performance. If such substitution, change or rearrangement materially affects the operating characteristics of the facility, the Company will provide reasonable notification to the customer in writing. Reasonable time will be allowed for any redesign and implementation required by the change in operating characteristics. The Company will work cooperatively with the customer to determine reasonable notification requirements.

Qwest Corporation
Private Line Transport Services
Catalog

State of North Dakota
Effective: 10-1-2001

SECTION 2
Page 5
Release 2

2. GENERAL REGULATIONS

2.1 UNDERTAKING OF THE COMPANY (Cont'd)

2.1.7 REFUSAL AND DISCONTINUANCE OF SERVICE

A. The Company, by written notice to the customer, may immediately discontinue the furnishing of Private Line Transport, without incurring any liability, upon:

- Nonpayment of any sum due the Company, or
- A violation of any condition governing the furnishing of service.

2.1.8 LIMITATION OF USE OF METALLIC FACILITIES

Signals applied to a metallic facility shall conform to the limitations set forth in the appropriate Technical Reference Publication. In the case of application of dc telegraph signaling systems, the customer shall be responsible, at its expense, for the provision of current limiting devices to protect the Company facilities from excessive current due to abnormal conditions and for the provision of noise mitigation networks when required to reduce excessive noise.

It is expressly declared that metallic facilities are in continually decreasing supply and the Company is not obligated to continue to provide such facilities. Due to facility rearrangements, continued use of metallic facilities may be denied to existing customers with no obligation on the Company's part to pay customer equipment rearrangement costs. The Company will give the customer 90 days notification of this type of facility rearrangements. Metallic facilities are provided only where existing facilities and operating conditions permit.

(M)
—
(M)

2.1.9 NOTIFICATION OF SERVICE-AFFECTING ACTIVITIES

The Company will provide the customer reasonable notification of service-affecting activities that may occur in normal operation of its business. Such activities may include, but are not limited to, equipment or facilities additions, removals or rearrangements, routine preventative maintenance and major switching machine change-out. Generally, such activities are not individual customer service specific, they affect many customer services. No specific advance notification period is applicable to all service activities. The Company will work cooperatively with the customer to determine the reasonable notification requirements.

(M) Material moved from Section 5, Page 15.

Qwest Corporation
Private Line Transport Services
Catalog

State of North Dakota
Effective: 3-9-2001

SECTION 2
Page 6
Release 1

2. GENERAL REGULATIONS

2.1 UNDERTAKING OF THE COMPANY (Cont'd)

2.1.10 COORDINATION WITH RESPECT TO NETWORK CONTINGENCIES

The Company intends to work cooperatively with the customer to develop network contingency plans in order to maintain maximum network capability following natural or man-made disasters which affect telecommunications services.

2.1.11 PROVISION AND OWNERSHIP OF TELEPHONE NUMBERS

The Company reserves the reasonable right to assign, designate or change telephone numbers, any other call number designations associated with Private Line Transport, or the Company serving office prefixes associated with such numbers, when necessary in the conduct of its business. Should it become necessary to make a change in such number(s), the Company will notify the customer of the effective date and an explanation of the reason(s) for such change(s).

2.1.12 SPECIAL TAXES, FEES AND CHARGES

Insofar as practicable, any sales, use, privilege, excise, franchise or occupation tax, costs of furnishing service without charge or similar taxes or impositions now or hereafter levied by the Federal, State, or Local government or any political subdivision or taxing authority thereof may be billed by the Company to its customers on a pro rata basis in the areas wherein such taxes, impositions or other charges shall be levied against the Company.

Qwest Corporation
Private Line Transport Services
Catalog

State of North Dakota
Effective: 3-9-2001

SECTION 2
Page 7
Release 1

2. GENERAL REGULATIONS

2.2 USE

2.2.1 INTERFERENCE OR IMPAIRMENT

- A. The characteristics and methods of operation of any circuits, facilities or equipment provided by other than the Company and associated with the facilities utilized to provide services under this Catalog shall not interfere with or impair service over any facilities of the Company, its affiliated companies, or its connecting and concurring carriers involved in its services, cause damage to their plant, impair the privacy of any communications carried over their facilities or create hazards to the employees of any of them or the public.

- B. Except as provided for equipment or systems subject to the F.C.C.'s Part 68 Rules in 47 C.F.R. Section 68.108, if such characteristics or methods of operation are not in accordance with A. preceding, the Company will, where practicable, notify the customer that temporary discontinuance of the use of a service may be required; however, where prior notice is not practicable, nothing contained herein shall be deemed to preclude the Company's right to temporarily discontinue forthwith the use of a service if such action is reasonable under the circumstances. In case of such temporary discontinuance, the customer will be promptly notified and afforded the opportunity to correct the condition which gave rise to the temporary discontinuance. During such period of temporary discontinuance, Credit Allowance for Service Interruptions, as set forth in 2.4.4, following, is not applicable.

2.2.2 UNLAWFUL USE

Private Line Transport shall not be used for any unlawful purposes.

Qwest Corporation
Private Line Transport Services
Catalog

State of North Dakota
Effective: 3-9-2001

SECTION 2
Page 8
Release 1

2. GENERAL REGULATIONS

2.3 OBLIGATIONS OF THE CUSTOMER

2.3.1 ORDERING, PAYMENT AND COMPLIANCE WITH TERMS AND CONDITIONS

- A. The customer shall be responsible for placing all orders for service, payment of all charges offered herein and compliance with Company regulations.
- B. The customer may not assign or transfer the use of services provided under this Catalog; however, where there is no interruption of use or relocation of the services, such assignment or transfer may be made to:
 - Another customer, whether an individual, partnership, association or corporation, provided the assignee or transferee assumes all outstanding indebtedness for such services, and the unexpired portion of the minimum period and the termination liability applicable to such services, if any, or;
 - A court-appointed receiver, trustee or other person acting pursuant to law in bankruptcy, receivership, reorganization, insolvency, liquidation or other similar proceedings, provided the assignee or transferee assumes the unexpired portion of the minimum period and the termination liability applicable to such services, if any.
- C. In all cases of assignment or transfer, the written acknowledgment of the Company is required prior to such assignment or transfer which acknowledgment shall be made within 15 days from the receipt of notification. All regulations and conditions contained in this Catalog shall apply to such assignee or transferee.
- D. The assignment or transfer of services does not relieve or discharge the assignor or transferor from remaining jointly or severally liable with the assignee or transferee for any obligations existing at the time of the assignment or transfer.

Qwest Corporation
Private Line Transport Services
Catalog

State of North Dakota
Effective: 3-9-2001

SECTION 2
Page 9
Release 1

2. GENERAL REGULATIONS

2.3 OBLIGATIONS OF THE CUSTOMER (Cont'd)

2.3.2 DAMAGES

The customer shall reimburse the Company for damages, to Company facilities utilized to provide services under this Catalog, caused by the negligence or willful act of the customer, or resulting from the customer's improper use of the Company facilities, or due to malfunction of any facilities or equipment provided by other than the Company. Nothing in the foregoing provision shall be interpreted to hold one customer liable for another customer's actions. The Company will, upon reimbursement for damages, cooperate with the customer in prosecuting a claim against the person causing such damage and the customer shall be subrogated to the right of recovery by the Company for the damages to the extent of such payment.

2.3.3 OWNERSHIP OF FACILITIES

Facilities utilized by the Company to provide service under the provisions of this Catalog shall remain the property of the Company. Such facilities shall be returned to the Company by the customer, whenever requested, within a reasonable period following the request in as good condition as reasonable wear will permit.

2.3.4 EQUIPMENT SPACE AND POWER

The customer shall furnish or arrange to have furnished to the Company, at no charge, equipment space and electrical power required by the Company to provide services under this Catalog at the POT of such services. The selection of ac or dc power shall be mutually agreed to by the customer and the Company. The customer shall also make necessary arrangements in order that the Company will have access to the premises at any reasonable hour for installing, testing, repairing or removing the facilities of the Company.

Qwest Corporation
Private Line Transport Services
Catalog

State of North Dakota
Effective: 3-9-2001

SECTION 2
Page 10
Release 1

2. GENERAL REGULATIONS

2.3 OBLIGATIONS OF THE CUSTOMER (Cont'd)

2.3.5 HAZARDOUS AND EXPLOSIVE ENVIRONMENTS

The customer shall be responsible for the provision, installation and maintenance of sealed conduit with explosive-proof fittings between facilities furnished by the Company in explosive atmosphere and points outside the hazardous area where connection may be made with regular facilities of the Company. The customer may also be required to install and maintain Company facilities within the hazardous area if, in the opinion of the Company, injury or damage to Company employees or property might result from installation or maintenance by the Company.

2.3.6 AVAILABILITY FOR TESTING

The services provided under this Catalog shall be available to the Company at times mutually agreed upon in order to permit the Company to make tests and adjustments appropriate for maintaining the services in satisfactory operating condition. Such tests and adjustments shall be completed within a reasonable time. No credit will be allowed for any interruptions involved during such tests and adjustment.

2.3.7 REFERENCES TO THE COMPANY

The customer may advise their end users that certain services are provided by the Company in connection with the service the customer furnishes to their end users; however, the customer shall not represent that the Company jointly participates in these services.

2.3.8 CLAIMS AND DEMANDS FOR DAMAGES

- A. With respect to claims of patent infringement made by third persons, the customer shall defend, indemnify, protect and save harmless the Company from and against all claims arising out of the combining with, or use in connection with, the services provided under this Catalog, any circuit, apparatus, system or method provided by the customer.

Qwest Corporation
Private Line Transport Services
Catalog

State of North Dakota
Effective: 3-9-2001

SECTION 2
Page 11
Release 1

2. GENERAL REGULATIONS

2.3 OBLIGATIONS OF THE CUSTOMER

2.3.8 CLAIMS AND DEMANDS FOR DAMAGES (Cont'd)

- B. The customer shall defend, indemnify and save harmless the Company from and against any suits, claims, losses or damages including punitive damages, attorney fees and court costs by third persons arising out of the construction, installation, operation, maintenance, or removal of the customer's circuits, facilities, or equipment connected to the Company's services provided under this Catalog, including, without limitation, Worker's Compensation claims, actions for infringement of copyright and/or unauthorized use of program material, libel and slander actions based on the content of communications transmitted over the customer's circuits, facilities or equipment, and proceedings to recover taxes, fines, or penalties for failure of the customer to obtain or maintain in effect any necessary certificates, permits, licenses, or other authority to acquire or operate the services provided under this Catalog; provided, however, the foregoing indemnification shall not apply to suits, claims, and demands to recover damages for damage to property, death, or personal injury unless such suits, claims or demands are based on the tortious conduct of the customer, its officers, agents or employees.

- C. The customer shall defend, indemnify and save harmless the Company from and against any suits, claims, losses or damages, including punitive damages, attorney fees and court costs by the customer or third parties arising out of any act or omission of the customer in the course of using services provided under this Catalog.

2.3.9 COORDINATION WITH RESPECT TO NETWORK CONTINGENCIES

The customer shall, in cooperation with the Company, coordinate in planning the actions to be taken to maintain maximum network capability following natural or man-made disasters which affect telecommunications services.

2.3.10 BUSINESS HOURS

Normal business hours are from Monday through Friday 8 a.m. to 5 p.m. Hours before 8 a.m. and after 5 p.m., Monday through Friday, and all of Saturdays are considered overtime. Sundays and Holidays are premium time.

Qwest Corporation
Private Line Transport Services
Catalog

State of North Dakota
Effective: 3-9-2001

SECTION 2
Page 12
Release 1

2. GENERAL REGULATIONS

2.4 PAYMENT ARRANGEMENTS AND CREDIT ALLOWANCES

2.4.1 END USER ACCOUNTS

A. Deposits

1. The Company may, in order to safeguard its interests, require an applicant or a customer to make a suitable deposit to be held by the Company as a guarantee of the payment of charges. A deposit would be requested where (a) satisfactory credit has not been established either by not having had previous service or through unsatisfactory payment habits on present or previous service; (b) information has not been initially produced indicating financial stability and ability to pay; or subsequent information indicates the lack of good credit or ability to pay. The amount of the deposit generally shall not exceed the estimated charges for the service which will accrue for a two-month period. The fact that a deposit has been made in no way relieves the applicant or customer from complying with the Company's regulations as to advance payments and the prompt payment of bills on presentation. The Company shall each year pay interest on such deposit at the rate paid by the Bank of North Dakota on a six-month certificate of deposit. Such rate will be determined as of the first business day of each year, on a six-month certificate of deposit with the smallest deposit required. The interest shall be applied as a credit to the subscriber's account annually. When the service is terminated the amount of the deposit with any interest due will be credited to the customer's account and any credit balance which may remain will be refunded. After the customer has established satisfactory credit through prompt payment habits over generally a nine to twelve month period of time the Company will refund the deposit with interest or credit it to the customer's account.

B. Advance Payments

1. In accordance with the Company's practice of requiring that all regularly recurring rates for services, equipment, and facilities be paid monthly in advance, an applicant for service will be required to pay in advance at the time application for service is made, the service and equipment and installation charges applicable, together with at least one month's charges for the services, equipment, and facilities applied for, and, where necessary, in the opinion of the Company, the estimated amount of construction charges.
2. The amount of the advance payment will be credited to the customer's account and applied to any indebtedness under the contract for service, equipment, and facilities furnished, and for service charges.

Qwest Corporation
Private Line Transport Services
Catalog

State of North Dakota
Effective: 3-9-2001

SECTION 2
Page 13
Release 1

2. GENERAL REGULATIONS

2.4 PAYMENT ARRANGEMENTS AND CREDIT ALLOWANCES

2.4.1 END USER ACCOUNTS (Cont'd)

- C. The customer is responsible for payment of all charges for facilities and services furnished, including charges for services originated, or charges accepted, at such facilities, in accordance with the Company's regular billing and collection practices.
- D. All charges for service, equipment, and facilities exclusive of charges for local messages in excess of the monthly allowance and toll messages, are payable monthly, in advance. Charges for local messages in excess of the monthly allowance and toll messages are payable monthly except that the Company reserves the right to require payment of such charges at more frequent intervals.

The Company may require payment of charges prior to the due date which may appear on any statement or bill rendered to the customer by the Company.

- E. Where the rates and charges for a particular service are determined by applying a percentage or similar factor to a quoted rate, and such computation results in a fraction, the charge for the service shall be computed to the nearest cent, a half cent being increased to the next higher cent.
- F. In the event a customer is indebted to the Company for charges and service rendered at a prior time, of any nature, or for service under one or more numbers at the same location, and the customer does not pay the charges or satisfy such indebtedness, the Company may charge and bill such indebtedness for a residence account against the same customer's residence service or a business account against the customer's business service.
- G. In the event that payment from a customer is less than the total amount of all charges owing to the Company and the customer does not specifically designate the manner to apply said payment, then the Company may apply all or any part of the payments received to such accounts or indebtedness in any manner the Company desires.

Qwest Corporation
Private Line Transport Services
Catalog

State of North Dakota
Effective: 3-9-2001

SECTION 2
Page 14
Release 1

2. GENERAL REGULATIONS

2.4 PAYMENT ARRANGEMENTS AND CREDIT ALLOWANCES

2.4.1 END USER ACCOUNTS (Cont'd)

- H. Payment which is not honored or paid by the customer's designated financial institution will be considered as nonpayment.
- I. In order to avoid collection procedures which could result in a temporary disconnection of service, payment must be received no later than the due and payable date shown on the customer's bill.
- J. Payments received by the Company on or before the due and payable date on the customer's bill will prevent collection procedures which could result in a disconnect of service provided the following billing information is remitted with payment. The following items are all contained on the customer's bill:
 - Customer's name
 - Customer's telephone/billing number
 - Customer's customer code
 - Customer's account type
 - Amount of payment

Qwest Corporation
Private Line Transport Services
Catalog

State of North Dakota
Effective: 3-9-2001

SECTION 2
Page 15
Release 1

2. GENERAL REGULATIONS

2.4 PAYMENT ARRANGEMENTS AND CREDIT ALLOWANCES

2.4.1 END USER ACCOUNTS (Cont'd)

- K. Payments received by the Company after the due and payable date on the customer's bill, but at least one day before the termination date on the suspension notice, may result in discontinuance of the customer's service unless the following billing information is remitted with payment:
- All of the items enumerated in J., preceding, and
 - The customer's advised final payment date before discontinuance for nonpayment.
- L. The Company will not be responsible if a customer's service is disconnected after payment has been remitted, unless the payment is made as set forth in J. or K., preceding, as applicable.
- M. Late Payment Charge
1. A late payment charge of 1 1/2% applies to all billed balances which are not paid by the billing date shown on the next bill, unless the balance is \$20.00 or less.
 2. Collection procedures, temporary disconnection of service, and the requirements for deposit are unaffected by the application of a late payment charge.
 3. The late payment charge does not apply to the following:
 - Billed amounts under dispute until the dispute is resolved against the customer.
 - Bills rendered more than 10 days after bill date.

Qwest Corporation
Private Line Transport Services
Catalog

State of North Dakota
Effective: 3-9-2001

SECTION 2
Page 16
Release 1

2. GENERAL REGULATIONS

2.4 PAYMENT ARRANGEMENTS AND CREDIT ALLOWANCES (Cont'd)

2.4.2 CARRIER ACCOUNTS

- A. The Company may, in order to safeguard its interests, require an applicant or a customer to make a suitable cash deposit or provide security in the form of a bank letter of credit, to be held by the Company as a guarantee of the payment of charges. Unless the criteria set forth in 4.a., following, are satisfied, an interexchange telecommunications company or a local exchange services reseller which purchases services that are resold to its customers or incorporated in services sold to its customers shall be required to provide to the Company a deposit or security (bank letter of credit) equal to two and one half months of estimated or actual billings. The deposit or security may be applied by the Company against any past due amount.
1. If the interexchange telecommunication company's or local exchange services reseller's actual usage of service exceeds by 5% or more the amount on which the existing deposit or security is based, the Company may require additional deposits or security based on actual usage.
 2. Any new or additional deposit or security required under authority of these rules, except as may be provided for elsewhere in these rules, is due and payable on the sixth business day after written notice of the deposit or security requirement is mailed to the interexchange telecommunications or local exchange services reseller company.
 3. The fact that a deposit or security has been made in no way relieves the interexchange telecommunications or local exchange services reseller company from complying with the Company's regulations as to the prompt payment of bills.

Qwest Corporation
Private Line Transport Services
Catalog

State of North Dakota
Effective: 3-9-2001

SECTION 2
Page 17
Release 1

2. GENERAL REGULATIONS

2.4 PAYMENT ARRANGEMENTS AND CREDIT ALLOWANCES

2.4.2 CARRIER ACCOUNTS

A. (Cont'd)

4. Deposits and security shall be refunded upon compliance with both a. (1) and (2), following.

a. Satisfactory Payment

Where the interexchange telecommunications or local exchange services reseller company has for 36 consecutive months paid for service when due in a prompt and satisfactory manner as evidenced by the following:

- (1) The Company has not initiated disconnection proceedings against the interexchange telecommunications or local exchange services reseller company; and
- (2) No more than two notices of delinquency within the last 12 month period have been made to the interexchange telecommunications or local exchange services reseller company by the Company.

b. Termination of Service

Upon termination of service, the Company shall return to the interexchange telecommunications or local exchange services reseller company the security, or the amount then on deposit plus accrued interest computed from the date of its receipt by the Company to the date of termination of service, less any amounts due the Company by the interexchange telecommunications or local exchange services reseller company for service rendered. Any deposit credits will be held until all usage is billed, but no longer than 45 days after the termination date. The Company shall each year pay interest on such deposit at the rate paid by the Bank of North Dakota on a six-month certificate of deposit. Such rate will be determined as of the first business day of each year, on a six-month certificate of deposit with the smallest deposit required. The interest shall be applied as a credit to the subscriber's account annually.

5. Should a larger or new deposit be required, the reasons shall be specified in writing to the interexchange telecommunications or local exchange services reseller company. Any requirement for a new or larger deposit or security shall be in conformity with the standards set forth in this section.

Qwest Corporation
Private Line Transport Services
Catalog

State of North Dakota
Effective: 3-9-2001

SECTION 2
Page 18
Release 1

2. GENERAL REGULATIONS

2.4 PAYMENT ARRANGEMENTS AND CREDIT ALLOWANCES

2.4.2 CARRIER ACCOUNTS (Cont'd)

- B. The Company shall bill on a current basis all charges incurred by and credits due to the customer under this Catalog attributable to services established or discontinued during the preceding billing period. In addition, the Company shall bill in advance charges for all services to be provided during the ensuing billing period except for charges associated with service usage and for the Federal Government which will be billed in arrears. The bill day (i.e., the billing date of a bill for a customer for Private Line Transport Service under this Catalog), the period of service each bill covers and the payment date will be as follows:
- The Company will establish a bill day each month for each customer account. The bill will cover nonusage sensitive service charges for the ensuing billing period. Payment for such bills is due as set forth in C., following. If payment is not received by the payment due date, as set forth in C., following, in immediately available funds, a late payment penalty will apply as set forth in D., following.
 - For billing purposes each month is considered to have 30 days.

Qwest Corporation
Private Line Transport Services
Catalog

State of North Dakota
Effective: 3-9-2001

SECTION 2
Page 19
Release 1

2. GENERAL REGULATIONS

2.4 PAYMENT ARRANGEMENTS AND CREDIT ALLOWANCES

2.4.2 CARRIER ACCOUNTS (Cont'd)

- C. All bills as set forth preceding, for service provided to the customer by the Company are due 31 days (payment due date) after the bill date or by the next bill date (i.e., same date in the following month as the bill date), whichever is the shortest interval, except as provided herein, and are payable in immediately available funds. If such payment due date would cause payment to be due on a Saturday, Sunday or Holiday (i.e., New Year's Day, Independence Day, Labor Day, Thanksgiving Day, Christmas Day, Veterans Day and a day when Washington's Birthday, Memorial Day or Columbus Day is legally observed), payment for such bills will be due from the customer as follows:
- If such payment due date falls on a Sunday or on a Holiday which is observed on a Monday, the payment due date shall be the first non-Holiday day following such Sunday or Holiday. If such payment due date falls on a Saturday or on a Holiday which is observed on Tuesday, Wednesday, Thursday or Friday, the payment due date shall be the last non-Holiday day preceding such Saturday or Holiday.
- D. Further, if any portion of the payment is received by the Company after the payment due date as set forth in C., preceding, or if any portion of the payment is received by the Company in funds which are not immediately available to the Company, then a late payment penalty shall be due to the Company. The late payment penalty shall be the portion of the payment not received by the payment due date times a late factor. The late factor shall be the lesser of:
- The highest interest rate (in decimal value) which may be levied by law for commercial transactions, compounded daily for the number of days from the payment due date to and including the date that the customer actually makes the payment to the Company, or
 - 0.000407 per day, compounded daily for the number of days from the payment due date to and including the date that the customer actually makes the payment to the Company.

Qwest Corporation
Private Line Transport Services
Catalog

State of North Dakota
Effective: 3-9-2001

SECTION 2
Page 20
Release 1

2. GENERAL REGULATIONS

2.4 PAYMENT ARRANGEMENTS AND CREDIT ALLOWANCES

2.4.2 CARRIER ACCOUNTS (Cont'd)

- E. In the event of a billing dispute, the customer must submit a documented claim for the disputed amount. If the claim is submitted within 90 days of the payment due date, any interest credits due the customer upon resolution of the dispute shall be calculated from the bill payment date. If the customer submits a claim for the disputed amount more than 90 days from the payment due date, any interest credits due the customer upon resolution of the dispute shall be calculated from the later of the date the claim was submitted or the bill payment date. Any undisputed amounts withheld by the customer in conjunction with disputed amounts withheld shall be subject to the late payment penalty as set forth in D., preceding. The Company will resolve the dispute and assess interest credits or penalties to the customer as follows:
- If the dispute is resolved in favor of the Company and the customer has paid the disputed amount on or before the payment due date, no interest credits or penalties will apply.
 - If the dispute is resolved in favor of the Company and the customer has withheld the disputed amount, any payments withheld pending settlement of the dispute shall be subject to the late payment penalty as set forth in D., preceding.
 - If the dispute is resolved in favor of the customer and the customer has withheld the disputed amount, no interest credits or penalties will apply.
 - If the dispute is resolved in favor of the customer and the customer has paid the disputed amount, the customer will receive an interest credit from the Company for the disputed amount times a late factor. The late factor shall be the lesser of:

Qwest Corporation
Private Line Transport Services
Catalog

State of North Dakota
Effective: 3-9-2001

SECTION 2
Page 21
Release 1

2. GENERAL REGULATIONS

2.4 PAYMENT ARRANGEMENTS AND CREDIT ALLOWANCES

2.4.2 CARRIER ACCOUNTS

E. (Cont'd)

- The highest interest rate (in decimal value) which may be levied by law for commercial transactions, compounded daily for the number of days from the date when payment was made or credit claimed in accordance with E., preceding, to and including the payment due date (as set forth in C., preceding) of the bill that reflects the credit for the disputed amount. In the event that the Company agrees to refund a credit by check or wire transfer, interest will be applied up to and including the date of issuance for either the check or wire transfer.
 - 0.000407 per day, compounded daily for the number of days from the date when payment was made or credit claimed in accordance with E., preceding, to and including the payment due date (as set forth in C., preceding) of the bill that reflects the credit for the disputed amount. In the event that the Company agrees to refund a credit by check or wire transfer, interest will be applied up to and including the date of issuance for either the check or wire transfer.
- F. Adjustments for the quantities of services established or discontinued in any billing period beyond the minimum period set forth for services in other sections of this Catalog will be prorated to the number of days or major fraction of days based on a 30 day month. The Company will, upon request and if available, furnish such detailed information as may reasonably be required for verification of any bill.
- G. When a rate as set forth in this Catalog is shown to more than two decimal places, the charges will be determined using the rate shown. The resulting amount will then be rounded to the nearest penny (i.e., rounded to two decimal places).
- H. When more than one copy of a customer bill for services provided under the provisions of this Catalog is furnished to the customer, an additional charge applies for each additional copy of the bill as set forth in 4.2, following.

Qwest Corporation
Private Line Transport Services
Catalog

State of North Dakota
Effective: 10-16-2007

SECTION 2
Page 22
Release 2

2. GENERAL REGULATIONS

2.4 PAYMENT ARRANGEMENTS AND CREDIT ALLOWANCES

2.4.2 CARRIER ACCOUNTS (Cont'd)

- I. Payment which is not honored or paid by the customer's designated financial institution will be considered as nonpayment.

2.4.3 CANCELLATION OF AN ORDER FOR SERVICE

Provisions for the cancellation of an order for Private Line Transport are set forth in 4.1.3, following.

2.4.4 CREDIT ALLOWANCE FOR SERVICE INTERRUPTIONS

A. General

A service is interrupted when it becomes unusable to the customer because of a failure of facilities used to furnish service under this Catalog. An interruption period starts when an inoperative service is found by the Company or reported to the Company and ends when the service is operative.

B. When a Credit Allowance Applies

In case of an interruption to any service, allowance for the period of interruption, if not due to the negligence of the customer, shall be as follows:

1. For Private Line Transport other than Foreign Exchange, Foreign Central Office, Exchange Service Extensions, Telephone Answering Service, Self-Healing Alternate Route Protection (SHARP) Service, no credit shall be allowed for an interruption of less than 4 hours. The customer shall be credited for an interruption of 4 hours or more at the rate of 1/180 of the monthly charges, except for Service Guarantee - Repair as specified in B.4., following, for the facility or service for each period of 4 hours or fraction thereof that the interruption continues, unless otherwise specified.

(C)

Qwest Corporation
Private Line Transport Services
Catalog

State of North Dakota
Effective: 3-9-2001

SECTION 2
Page 23
Release 1

2. GENERAL REGULATIONS

2.4 PAYMENT ARRANGEMENTS AND CREDIT ALLOWANCES

2.4.4 CREDIT ALLOWANCE FOR SERVICE INTERRUPTIONS

B.1. (Cont'd)

The monthly charges used to determine the credit, including Service Guarantee - Repair as specified in B.4., following, shall be as follows:

- a. For two-point services, the monthly charge shall be the total of all the monthly rate element charges associated with the service (i.e., Network Access Channel, Channel Termination, Channel Performance, Transport Mileage and Optional Features and Functions).
- b. For multipoint services, the monthly charge shall be only the total of all the monthly rate element charges associated with that portion of the service that is inoperative (i.e., a Network Access Channel or Channel Termination per customer designated premises, Channel Performance, Transport Mileage and Optional Features and Functions).
- c. For multiplexed services, the monthly charge shall be the total of all the monthly rate element charges associated with that portion of the service that is inoperative. When the facility which is multiplexed or the multiplexer itself is inoperative, the monthly charge shall be the total of all the monthly rate elements associated with the service (i.e., the Network Access Channel, Channel Termination, Channel Performance, Transport Mileage, and Optional Features and Functions, including the multiplexer on the facility to the wire center, and the Network Access Channel, Channel Performance, Transport Mileage and Optional Features and Functions on the individual services from the wire center). When the service which rides a channel of the multiplexed facility is inoperative, the monthly charge shall be the total of all the monthly rate element charges associated with that portion of the service from the wire center to a customer premises.

The credit allowance(s) for an interruption or for a series of interruptions shall not exceed the monthly rate for the service interrupted in any one monthly billing period. For the purpose of determining the allowance every month is considered to have 30 days.

Qwest Corporation
Private Line Transport Services
Catalog

State of North Dakota
Effective: 10-16-2007

SECTION 2
Page 24
Release 2

2. GENERAL REGULATIONS

2.4 PAYMENT ARRANGEMENTS AND CREDIT ALLOWANCES

2.4.4 CREDIT ALLOWANCE FOR SERVICE INTERRUPTIONS

B. When a Credit Allowance Applies (Cont'd)

2. For Foreign Exchange Service, Foreign Central Office Service, Exchange Service Extensions, or Telephone Answering Service, no credit shall be allowed for an interruption of less than 24 hours. The customer shall be credited for an interruption of 24 hours or more at the rate of 1/30 of (a) any applicable monthly rates, (b) the assumed minutes of use charge, or (c) the minimum monthly usage charge for each period of 24 hours or fraction thereof that the interruption continues. However, in no case is a credit allowance applicable when the actual usage charge exceeds the minimum monthly usage charge in any one monthly billing period.

3. For Self-Healing Alternate Route Protection (SHARP), an out of service credit will apply when the customer experiences a service interruption and the system fails to switch to the protected electronics and/or facilities within one second. The protected electronics and/or facilities are between the Company Demarcation Point serving the customer premises and/or the Company Wire Center(s) associated with the SHARP option. Such credit will be based on information provided by the network surveillance system associated with SHARP. In the event of a service interruption, one month's billing credit of the protected service will be given. Such credit will apply to the Channel Termination and the SHARP rate element for SHARP protected service. Credit will be limited to a maximum of one month for an interruption or series of interruptions within that month. Credit will be limited to a maximum of one month for an interruption or series of interruptions within that month. (C)

Qwest Corporation
Private Line Transport Services
Catalog

State of North Dakota
Effective: 3-9-2001

SECTION 2
Page 25
Release 1

2. GENERAL REGULATIONS

2.4 PAYMENT ARRANGEMENTS AND CREDIT ALLOWANCES

2.4.4 CREDIT ALLOWANCE FOR SERVICE INTERRUPTIONS

B. When a Credit Allowance Applies (Cont'd)

4. Service Guarantee - Repair

The Company assures that all service interruptions for DS1 and DS3 Service, excluding Free-Frame DS1, will be restored within four (4) hours from the time the interruption was reported by the customer. Failure to meet this commitment will result in a credit allowance as set forth in b., following.

- a. In addition to B.1. through B.3., preceding, as applicable, the following regulations apply to Service Guarantee - Repair:
- A service is interrupted when it becomes unusable to the customer because of a failure of a facility component used to furnish service under this Catalog or in the event that the protective controls applied by the Company result in the complete loss of service by the customer. An interruption period starts when an inoperative service is reported and ends when the service is operative.
 - The interruption period is based on the start and stop time of the service interruption and excludes customer requested monitoring and other times when the service or customer's premises is not available for testing or repair of the service.
 - The credit allowance for an interruption or a series of interruptions shall not exceed any applicable monthly charges for the service interrupted in any one monthly billing period, as determined in B.1., preceding.

Qwest Corporation
Private Line Transport Services
Catalog

State of North Dakota
Effective: 04-19-2017

SECTION 2
Page 26
Release 2

2. GENERAL REGULATIONS

2.4 PAYMENT ARRANGEMENTS AND CREDIT ALLOWANCES

2.4.4 CREDIT ALLOWANCE FOR SERVICE INTERRUPTIONS

B.4. (Cont'd)

b. Service Guarantee - Repair Credit

	CREDIT	(T)
• DS1 Service		
- 4 hours up to but not including 8 hours	\$ 60.00	(T)
- 8 hours up to but not including 16 hours	70.00	
- 16 hours up to but not including 24 hours	80.00	
- 24 hours and over	100.00	(T)
• DS3 Service		
- 4 hours up to but not including 8 hours	500.00	(T)
- 8 hours up to but not including 16 hours	700.00	
- 16 hours up to but not including 24 hours	800.00	
- 24 hours and over	1,000.00	(T)

Qwest Corporation
Private Line Transport Services
Catalog

State of North Dakota
Effective: 10-16-2007

SECTION 2
Page 27
Release 2

2. GENERAL REGULATIONS

2.4 PAYMENT ARRANGEMENTS AND CREDIT ALLOWANCES

2.4.4 CREDIT ALLOWANCE FOR SERVICE INTERRUPTIONS (Cont'd)

C. When a Credit Allowance Does Not Apply

No credit allowance will be made for:

1. Interruptions caused by the negligence of the customer.
2. Interruptions of a service due to the failure of equipment or systems provided by the customer or others.
3. Interruptions of a service during any period in which the Company is not afforded access to the premises where the service is terminated.
4. Interruptions of a service when the customer has released that service to the Company for maintenance purposes, to make rearrangements, or for the implementation of an order for a change in the service during the time that was negotiated with the customer prior to the release of that service.
5. Interruptions of a service which continue because of the failure of the customer to authorize replacement of any element of Special Construction, as set forth in 4.1.6, following. The period for which no credit allowance is made begins on the seventh day after the customer receives the Company's written notification of the need for such replacement and ends on the day after receipt by the Company of the customer's written authorization for such replacement.
6. Periods when the customer elects not to release the service for testing and/or repair and continues to use it on an impaired basis.
7. An interruption or a group of interruptions, resulting from a common cause, for amounts less than one dollar.
8. In addition to C.1. through C.7., preceding, as applicable, Service Guarantee - Repair credit allowances do not apply to:
 - SHARP and Specialized Service and Arrangements. (C)
 - Service interruptions due to natural disasters (e.g., tornado, earthquake, fire or flood) or work stoppage.

Qwest Corporation
Private Line Transport Services
Catalog

State of North Dakota
Effective: 3-9-2001

SECTION 2
Page 28
Release 1

2. GENERAL REGULATIONS

2.4 PAYMENT ARRANGEMENTS AND CREDIT ALLOWANCES

2.4.4 CREDIT ALLOWANCE FOR SERVICE INTERRUPTIONS (Cont'd)

D. Use of an Alternative Service Provided by the Company

Should the customer elect to use an alternative service provided by the Company during the period that a service is interrupted, the customer must pay the appropriate rates and charges for the alternative service used.

E. Temporary Surrender of a Service

In certain instances, the customer may be requested by the Company to surrender a service for purposes other than maintenance, testing or activity relating to a service order. If the customer consents, a credit allowance will be granted. The credit allowance will be 1/1440 of the monthly rate for each period of 30 minutes or fraction thereof that the service is surrendered. In no case will the credit allowance exceed the monthly rate for the service surrendered in any one monthly billing period.

Qwest Corporation
Private Line Transport Services
Catalog

State of North Dakota
Effective: 3-9-2001

SECTION 2
Page 29
Release 1

2. GENERAL REGULATIONS

2.4 PAYMENT ARRANGEMENTS AND CREDIT ALLOWANCES (Cont'd)

2.4.5 ORDERING, RATING AND BILLING OF PRIVATE LINE TRANSPORT WHERE MORE THAN ONE EXCHANGE TELEPHONE COMPANY IS INVOLVED

The Company, if requested by the customer, will handle ordering, rating and billing of that portion of Private Line Transport that it provides. When service is jointly provided by the Company and another Local Exchange Company, the following will apply:

- A. Each Local Exchange Company will provide the portion of the mileage element in its operating territory and will bill its rates and charges.
- B. The rate for the mileage element for services provided as set forth in A., preceding is determined as follows:
 1. The appropriate mileage is determined by computing the airline mileage between each premises serving wire center using the V&H methods as set forth in the National Exchange Carrier Association Tariff F.C.C. No. 4.
 2. The billing percentages will be agreed upon by the Local Exchange Companies involved and are listed in the National Exchange Carrier Association Tariff F.C.C. No. 4 or other billing percentage document agreed to by the companies involved.
 3. Using rates for the airline mileage determined in 1., preceding, multiply the rates by the Company's billing percentage to obtain the mileage element charges.

Qwest Corporation
Private Line Transport Services
Catalog

State of North Dakota
Effective: 3-9-2001

SECTION 2
Page 30
Release 1

2. GENERAL REGULATIONS

2.4 PAYMENT ARRANGEMENTS AND CREDIT ALLOWANCES

2.4.5 ORDERING, RATING AND BILLING OF PRIVATE LINE TRANSPORT WHERE MORE THAN ONE EXCHANGE TELEPHONE COMPANY IS INVOLVED (Cont'd)

- C. When Private Line Transport service is provided jointly between the Company and another Local Exchange Company, the appropriate recurring rates and nonrecurring charges are applied as follows:
 - 1. The appropriate Private Line Mileage rates and nonrecurring charges are applied as specified in B.3., preceding.
 - 2. All other appropriate Private Line Transport recurring rate elements (e.g., Network Access Channel and Channel Performance) and their associated nonrecurring charges apply at 100 percent.
- D. When Private Line Transport service is provided jointly and the Company is the intermediate non-terminating carrier, only the recurring mileage rate applies. The rate is determined by multiplying the appropriate mileage rate by the billing percentage.
- E. When Private Line Transport service is provided jointly between the Company and another Local Exchange Company, or when the Company is the intermediate non-terminating carrier, the appropriate nonrecurring charges apply as set forth in Section 5 of this Catalog.

Qwest Corporation
Private Line Transport Services
Catalog

State of North Dakota
Effective: 3-9-2001

SECTION 2
Page 31
Release 1

2. GENERAL REGULATIONS

2.4 PAYMENT ARRANGEMENTS AND CREDIT ALLOWANCES

2.4.5 ORDERING, RATING AND BILLING OF PRIVATE LINE TRANSPORT WHERE MORE THAN ONE EXCHANGE TELEPHONE COMPANY IS INVOLVED (Cont'd)

F. Example - Private Line Transport

1. Layout

- a. Private Line Transport is ordered to a serving wire center which is in the operating territory of the Company.
- b. Premises of ordering customer is in operating territory of another Local Exchange Company.

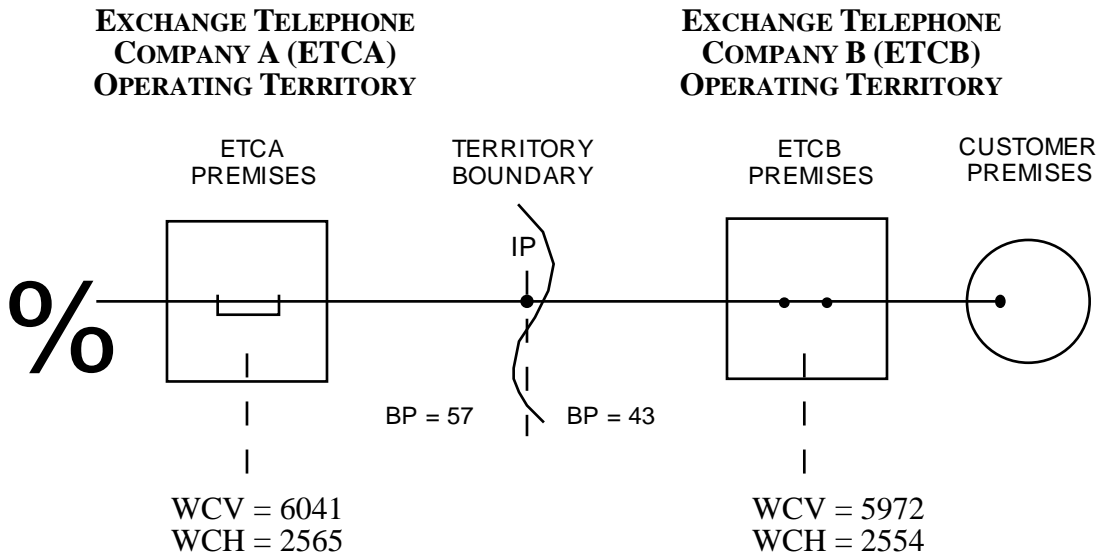

NOTICE
THE INFORMATION CONTAINED IN THIS DOCUMENT IS SUBJECT TO CHANGE.

Qwest Corporation
Private Line Transport Services
Catalog

State of North Dakota
Effective: 3-9-2001

SECTION 2
Page 32
Release 1

2. GENERAL REGULATIONS

2.4 PAYMENT ARRANGEMENTS AND CREDIT ALLOWANCES

2.4.5 ORDERING, RATING AND BILLING OF PRIVATE LINE TRANSPORT WHERE MORE THAN ONE EXCHANGE TELEPHONE COMPANY IS INVOLVED

F. Example - Private Line Transport (Cont'd)

2. Airline Mileage (Using National Exchange Carrier Association Tariff F.C.C. No. 4)
3. Transport Mileage
 - Qwest Corporation premises to LEC premises = 22.1, rounded = 23
 - Assume Qwest Corporation rate for mileage is \$2.00 per mile.
 - Assume Qwest Corporation Billing Percentage (BP) is 57.
 - Calculation of Mileage Rates

Qwest Mileage Rate = 23 X \$2.00 X 57% = \$26.22

4. The rates and charges for the mileage provided by another Local Exchange Company will be billed by that company.

Qwest Corporation
Private Line Transport Services
Catalog

State of North Dakota
Effective: 3-9-2001

SECTION 2
Page 33
Release 1

2. GENERAL REGULATIONS

2.4 PAYMENT ARRANGEMENTS AND CREDIT ALLOWANCES (Cont'd)

2.4.6 TERMINATION LIABILITY/WAIVER POLICY

All Private Line Transport Services provided via service agreements are subject to the Termination Liability/Waiver Policy, unless otherwise specified.

A. Minimum Billing Level

When services are provided under a fixed-period service agreement, a Minimum Billing Level will be established for use in calculating discontinuance charges. The Minimum Billing Level is 100% of the total monthly rates for the service provided under the customer's service agreement, unless otherwise specified. Partial discontinuance of service will not decrease the Minimum Billing Level.

B. Minimum Service Period

When services are provided under a service agreement, a Minimum Service Period may be established. This would be the period of time that the 100% factor of the Termination Liability Charge would apply.

C. Complete Disconnect

If the customer chooses to completely discontinue contracted service, at any time during the term of the agreement, a termination charge will apply, unless the customer satisfies the conditions specified in the Waiver Policy. The termination charge is 100% of the rates for the Minimum Service Period, if applicable, plus the Minimum Billing Level multiplied by the termination liability percentage specified in the service agreement, for the remaining term of the agreement.

- For example, if the customer discontinues service after 17 months of a 3-year (36 month) agreement, the termination charge will be the Minimum Billing Level for the service multiplied by the termination liability percentage, multiplied by 19 months.
- If the customer discontinues service after 6 months of a 3-year (36 month) agreement, with a 1-year (12 months) Minimum Service Period, the Termination Charge will be 100% of the Minimum Billing Level for the remaining 6 months of the Minimum Service Period, plus the Minimum Billing Level multiplied by the termination liability percentage, multiplied by 24 months.

Qwest Corporation d/b/a CenturyLink QC
Private Line Transport Services
Catalog

State of North Dakota
Effective: 05-05-2017

SECTION 2
Page 34
Release 2

2. GENERAL REGULATIONS

2.4 PAYMENT ARRANGEMENTS AND CREDIT ALLOWANCES

2.4.6 TERMINATION LIABILITY/WAIVER POLICY (Cont'd)

D. Partial Disconnect

If the customer discontinues a portion of their contracted service, and that causes the customer's monthly billing level to fall below the Minimum Billing Level of the agreement, a termination charge will apply to the portion of the service agreement that is below the Minimum Billing Level.

E. Waiver Policy

A waiver of the termination charge as set forth in C. and D., preceding, may occur if the customer moves to a different location within the Company territory or migrates to another Company service. When the customer is purchasing these services to offer to third party end users, the end user must be the same for both the old and new service. In the case of a move to a different building, the end user must be the same at the old and new location. In the case of a migration to another Company service or transmission speed, the end user must be the same for the original service and the new service or transmission speed at the current location. A termination charge will be waived when the customer discontinues their contracted service(s), provided all of the following conditions are met:

- The customer signs a new service agreement for any other Company provided service(s);
- Both the existing and the new service(s) are provided solely by the Company;
- The order to discontinue the existing service(s) and the order to establish the new service(s) are received by the Company at the same time;
- The new service(s) installation must be completed within thirty calendar days of the disconnection of the old service(s), unless the installation delay is caused by the Company;
- The total value of the new service agreement(s), excluding any special construction charges and any other nonrecurring charges, is equal to or greater than 115% of the remaining value of the existing agreement(s);
- A new minimum service period goes into effect when the new service agreement term begins;
- The customer agrees to pay any previously billed, but unpaid recurring, and any outstanding nonrecurring charges. These charges cannot be included as part of the new service agreement;
- All applicable nonrecurring charges will be assessed for the new contracted service(s).

(T)
—
(T)

Qwest Corporation
Private Line Transport Services
Catalog

State of North Dakota
Effective: 3-9-2001

SECTION 2
Page 35
Release 1

2. GENERAL REGULATIONS

2.5 CONNECTIONS

2.5.1 GENERAL

Equipment and Systems (i.e., terminal equipment, multiline terminating systems and communications systems) may be connected with Private Line Transport furnished by the Company where such connection is made in accordance with the provisions specified in the code of Federal Regulations, Title 47, Chapter 1, Federal Communications Commission, Part 68, Connection of Terminal Equipment to the Telephone Network and 2.1, preceding.

Qwest Corporation
Private Line Transport Services
Catalog

State of North Dakota
Effective: 3-9-2001

SECTION 2
Page 36
Release 1

2. GENERAL REGULATIONS

2.6 DEFINITIONS

Certain terms used herein are defined as follows:

Attenuation Distortion

Denotes the differences in loss at specified frequencies relative to the loss at 1004 Hz, unless otherwise specified.

Audio Transmission

Denotes speech or music transmission by means of an Audio channel.

Authorized User

Denotes a person, firm, or corporation who is authorized by the customer to be connected to the service of the customer. An authorized user must be specifically named in the application for service and a termination of the service must be located at the authorized user's premises.

Automatic Ringdown

Denotes a two-point or multipoint channel with Company provided signaling at a serving wire center. Either end of the channel can originate a seizure which will cause a 20 Hz ringing signal to be applied to the remote ends until answered. The customer must identify primary and remote stations.

Base Rate Area

Denotes that portion of the exchange area surrounding and including the serving wire center within which urban classes of local service are offered at rates that do not vary with the distance from the serving wire center or exchange rate center.

Baud

Denotes a unit of signaling speed. It is the reciprocal of the time duration in seconds of the shortest signal element (binary 1 or 0) within a code signal. The rates specified are the number of signal elements per second.

2. GENERAL REGULATIONS

2.6 DEFINITIONS (Cont'd)

Bit

Denotes the smallest unit of information in the binary system of notation.

Bridging

Denotes the process of connecting three or more customer locations.

Business Day

Denotes the times of day that a company is open for business. Generally, in the business community, these are 8:00 a.m. to 5:00 p.m. with an hour for lunch, Monday through Friday, resulting in a standard forty (40) hour work week.

Carrier or Common Carrier

See "Interexchange Carrier".

Central Office (CO)

Denotes a local switching unit providing local telephone service to customers within an exchange or wire center serving area. More than one Central Office may be located in the same wire center.

Central Office Prefix

Denotes the first three digits (NXX) of the seven digit telephone number assigned to a customer's Telephone Exchange Service when dialed on a local basis.

Channel(s)

Denotes the individual segment(s) of a circuit.

Channel Service Unit

Denotes equipment which performs one or more of the following functions: termination of a digital facility, regeneration of digital signals, detection and/or correction of signal format errors, and remote loop back.

Qwest Corporation
Private Line Transport Services
Catalog

State of North Dakota
Effective: 3-9-2001

SECTION 2
Page 38
Release 1

2. GENERAL REGULATIONS

2.6 DEFINITIONS (Cont'd)

Channel Performance

Denotes establishing or enhancing the performance characteristics of a channel.

Circuit

Denotes facilities and/or equipment necessary to provide a specific service.

Class of Service

Denotes a subgrouping of customers typically for the purpose of rate distinctions.

Common Line

Denotes a line, trunk, pay telephone line or other facility provided under the appropriate Price Schedule of the Company terminated on a central office switch. A common line-residence or business is a line or trunk provided under the residence terms and conditions of the Exchange and Network Services Price Schedule.

Communication System

Denotes channels and other facilities which are capable of communications between terminal equipment provided by other than the Company.

Qwest Corporation
Private Line Transport Services
Catalog

State of North Dakota
Effective: 3-9-2001

SECTION 2
Page 39
Release 1

2. GENERAL REGULATIONS

2.6 DEFINITIONS (Cont'd)

Conditioning

Denotes an enhancement to the transmission performance of a Voice Grade circuit. Performance(s) affected are attenuation distortion, envelope delay, distortion and noise.

Contact Closure

Denotes the low resistance short provided by a pair of electrical contacts which indicate a change in signaling states on a circuit.

Continuous Property

Denotes the land, including any building or buildings thereon, occupied or used in the conduct of one establishment or business, throughout which there is a general access without the necessity of crossing land used publicly or privately by others.

Contract

Denotes the service agreement between a customer and the Company under which facilities for communication between specified locations, for designated periods, and for the use of the customer and the authorized users specifically named in the contract are furnished in accordance with the provision of this Catalog.

Control Leg

Denotes the specific leg of a multipoint circuit used by the customer to broadcast to all tributary legs and to control all tributary legs so that only one tributary is transmitting back towards the control leg at a time.

Customer(s)

Denotes any individual, partnership, association, joint-stock company, trust, corporation, governmental entity or any other entity which subscribes to the services offered under this Catalog, including both Interexchange Carriers (ICs) and/or End Users.

Demarcation Point

See "Point of Termination (POT)".

2. GENERAL REGULATIONS

2.6 DEFINITIONS (Cont'd)

Design Layout Report (DLR)

Denotes a document which describes the circuit provided by the Company and matches the service ordered by the customer.

Duplex

Denotes service which provides for simultaneous transmission in both directions.

E&M Signaling Arrangements

Denotes a method of transmitting signaling between switching equipment.

Echo Control

Denotes the control of reflected electrical energy in a telephone transmission path.

Echo Return Loss (ERL)

Denotes the weighted average of the return loss of all frequencies between 560 and 1965 Hz.

Effective 2-Wire

Denotes a channel consisting of a single electrical path capable of voice grade transmission in both directions, but not simultaneously, and which is 2-Wire at the points of termination.

Effective 4-Wire

Denotes a channel comprised entirely of 4-Wire facilities. The channel may be terminated as 2-Wire or 4-Wire at the end-user. The termination at the Interexchange Carrier Point Of Termination (IC POT) must be 4-Wire. When terminated as 2-Wire it is not possible to ensure independent information transmission simultaneously in both directions.

End-Link or Mid-Link

Denotes one end of a two-point (end-link) or multipoint (mid-link) circuit that is transported interLATA.

Qwest Corporation
Private Line Transport Services
Catalog

State of North Dakota
Effective: 3-9-2001

SECTION 2
Page 41
Release 1

2. GENERAL REGULATIONS

2.6 DEFINITIONS (Cont'd)

End Office Switch

Denotes a local Telephone Company switching system where Telephone Exchange Service Customer station loops are terminated for purposes of interconnection to trunks.

End to End

Denotes a circuit that is transported from a customer's premises to other premises location(s) within the LATA.

End-User (EU)

Denotes any customer of telecommunications service that is not a carrier, except that a carrier shall be deemed to be an "end-user" to the extent that such carrier uses a telecommunications service for administrative purposes without making such service available to others, directly or indirectly.

Envelope Delay Distortion (EDD)

Denotes a measure of the linearity of the phase-versus-frequency characteristic of a channel.

Equal Level Echo Path Loss (ELEPL)

Denotes the measure of Echo Path Loss (EPL) at a four-wire interface which is corrected by the difference between the send and receive Transmission Level Point (TLP). [ELEPL = EPL - TLP (send) + TLP (receive)]

Exchange

Denotes a unit established for the administration of communication service in a specified area which usually embraces a city, town, or village and its environs. It consists of one or more wire centers together with the associated facilities used in furnishing communication service within the area.

Exchange Area

Denotes the territory served by an exchange.

Qwest Corporation
Private Line Transport Services
Catalog

State of North Dakota
Effective: 04-19-2017

SECTION 2
Page 42
Release 2

2. GENERAL REGULATIONS

2.6 DEFINITIONS (Cont'd)

Exchange Carrier

Denotes any individual, partnership, association, joint-stock company, trust, governmental entity or corporation engaged for hire in intraLATA intrastate communication by wire, radio, fiber optics or any suitable technology or a combination thereof, between two or more exchanges.

(D)
—
(D)

First Come, First Served

Denotes a procedure followed when the first order received will be the first order processed.

Frequency Shift

Denotes the change in the frequency of a tone as it is transmitted over a channel.

Half Duplex

Denotes service which provides for transmission in both directions, but in only one direction at a time.

Host Office

Denotes an electronic switching system which provides call processing capabilities for one or more Remote Switching Modules or Remote Switching Systems.

2. GENERAL REGULATIONS

2.6 DEFINITIONS (Cont'd)

Immediately Available Funds

Denotes a corporate or personal check drawn on a bank account and funds which are available for use by the receiving party on the same day on which they are received and include U.S. Federal Reserve bank wire transfers, U.S. Federal Reserve notes (paper cash), U.S. coins, U.S. Postal Money Orders and New York Certificates of Deposit.

Impulse Noise

Denotes any momentary occurrence of the noise on a channel over a specified level threshold. It is evaluated by counting the number of occurrences which exceed the specified threshold.

Individual Case Bases (ICB)

Denotes a condition in which the terms and conditions, if applicable and rates and charges for an offering under the provisions of this Catalog are developed based on the circumstances in each case.

Interexchange Carrier (IC) or Interexchange Common Carrier

Denotes any individual, partnership, association, joint-stock company, trust, governmental entity or corporation engaged for hire in intrastate communication between two or more exchanges.

Intermodulation Distortion

Denotes a measure of the nonlinearity of a channel. It is measured using four tones, and evaluating the ratios (in dB) of the transmitted composite four-tone signal power to the second-order products of the tones (R2), and the third-order products of the tones (R3).

Interstate Communications

Denotes both interstate and foreign communications.

2. GENERAL REGULATIONS

2.6 DEFINITIONS (Cont'd)

Intrastate Communications

Denotes any communications within a state subject to oversight by a state regulatory commission as provided by the laws of the state involved.

Local Access and Transport Area (LATA)

Denotes a geographic area established for the provision and administration of communications service. It encompasses one or more designated exchanges, which are grouped to serve common social, economic and other purposes.

Maintenance of Service

Denotes an occurrence of a visit to a customer's premises in connection with a service difficulty when it is determined that the difficulty is due to a condition in customer-provided facilities, terminal equipment, a communication system or for customer-maintained premises wire.

McCulloh Loop Signaling

Denotes a signaling format which provides a contact closure to the tip and ring of the POT during the normal state. During an alarm state a momentary open is provided. During the signaling state a series of grounded pulses are applied to the POT for termination and identification purposes.

Modification of Final Judgment (MFJ)

Denotes the consent decree approved by the U.S. District Court in United States versus Western Electric 552 F. Supp. 171 (To D.C. 1982).

Move

Denotes a change in the physical location of one of the following:

- The Point of Termination at the customer's designated premises.
- The customer's premises.

Qwest Corporation
Private Line Transport Services
Catalog

State of North Dakota
Effective: 3-9-2001

SECTION 2
Page 45
Release 1

2. GENERAL REGULATIONS

2.6 DEFINITIONS (Cont'd)

Network Access Channel

Denotes the transmission path between a customer-designated premises and the serving wire center of the premises.

Network Interface

See "Point of Termination (POT)".

Noncontinuous Property

Denotes land, including the building or buildings thereon, which is divided by rights of way or by land used publicly or privately by others, i.e., city streets, state highways or roads, or private property.

Nonrecurring Charge

Denotes those charges which are one-time charges to the customer, i.e., not monthly charges.

Qwest Corporation
Private Line Transport Services
Catalog

State of North Dakota
Effective: 3-9-2001

SECTION 2
Page 46
Release 1

2. GENERAL REGULATIONS

2.6 DEFINITIONS (Cont'd)

Obsolete

Denotes certain services offered in other sections of this Catalog that are provided to existing customers only and not provided to new customers or to existing customers who move from one premises to another.

Ohm

Denotes a unit of electrical resistance.

Optional Features and Functions

Denotes options available to change the basic circuit's quality or utility. Examples of Optional Features and Functions include, but are not limited to, the following:

- Bridging
- Conditioning

Order Code

Denotes a three or five character alphabetic, numeric, or an alphanumeric code that identifies a specific item of service. Uniform order codes are used in the Company's billing system to generate recurring rates and nonrecurring charges.

Qwest Corporation
Private Line Transport Services
Catalog

State of North Dakota
Effective: 3-9-2001

SECTION 2
Page 47
Release 1

2. GENERAL REGULATIONS

2.6 DEFINITIONS (Cont'd)

Point of Termination (POT)

Denotes the point of interconnection between Company communications facilities and terminal equipment, protective apparatus or wiring at or near a customer's premises. The POT shall be located on the customer's side of the Company's protector, or the equivalent thereof in cases where a protector is not employed, as provided under the Company's reasonable and nondiscriminatory standard operating practices. Previously known as "Network Interface" and "Demarcation Point".

Premises

Denotes a building, or a portion of a building in a multi-tenant building, or buildings on continuous property (except railroad rights-of-way, etc.) not separated by a public highway.

Premises Work Charge

Denotes Work Charges (Time and Material Charges) for work performed on the customer's side of the Network Interface by a Company employee or representative, at the customer's request, which are not covered by other charges.

Private Branch Exchange (PBX)

Denotes a switching system that provides internal telephone communications between stations located on a customer's premises as well as between these stations and exterior networks.

2. GENERAL REGULATIONS

2.6 DEFINITIONS (Cont'd)

Remote Switching Modules and/or Remote Switching Systems

Denotes small, remotely controlled electronic end office switches which obtain their call processing capability from an ESS-type Host Office. The Remote Switching Modules and/or Remote Switching Systems cannot accommodate direct-in-dialed trunks to a customer.

Return Loss

Denotes a measure of the similarity between the two impedances at the junction of two transmission paths. The higher the return loss, the higher the similarity.

Same Building

Denotes a structure under one roof, or two or more structures under separate roofs, throughout which there is general access by means of a door, elevators, stairways, enclosed passageways or continuous corridors. Sidewalks, driveways, heating and utility tunnels, pipes and conduits are not considered enclosed passageways.

Serving Wire Center

Denotes the Company office from which dial tone for local exchange service would normally be provided to the customer's premises.

Shortage of Facilities or Equipment

Denotes a condition which occurs when the Company does not have appropriate cable, bridging or, multiplexing equipment, etc., necessary to provide the service requested by the customer.

Signaling

Denotes the transmission of information to establish, monitor, or release connections and/or provide Network Control.

2. GENERAL REGULATIONS

2.6 DEFINITIONS (Cont'd)

Singing Return Loss

Denotes the frequency-weighted measure of return loss at the edges of the Voice Grade (200 to 500 Hz and 2500 to 3200 Hz), where singing (instability) problems are most likely to occur.

Studio

Denotes the term as used in connection with Audio Service to indicate the fixed premises of a customer at which (1) program material regularly originates or (2) program material is received for transmission and at which location amplifier-distributor equipment is provided by the customer. The term Studio also indicates premises at which personnel of the customer are present, or in lieu of personnel, the customer provides supervision and control equipment.

Termination Liability

Denotes a specified financial obligation assumed by the customer, to protect the Company's nonrecoverable investment over a specified period of time. The maximum amount of liability is reduced each month during the life of the agreement, and is billed to the customer only if the agreement is terminated or modified.

Transmission Path

Denotes a path capable of transmitting signals within the range of the service offering, e.g., a Voice Grade transmission path is capable of transmitting voice frequencies within the approximate range of 300 to 3000 Hz. A transmission path is comprised of physical or derived channels consisting of any form or configuration of facilities typically used in the telecommunications industry.

Transport Mileage

Denotes that portion of a Private Line Transport which connects two wire centers.

Qwest Corporation
Private Line Transport Services
Catalog

State of North Dakota
Effective: 4-20-2009

SECTION 2
Page 50
Release 2

2. GENERAL REGULATIONS

2.6 DEFINITIONS (Cont'd)

Trunk

Denotes a communications path connecting two switching systems in a network, used in the establishment of an end-to-end connection.

Trunk Group

Denotes a set of trunks that are traffic engineered as a unit for the establishment of connections between switching systems in which all of the communications paths are interchangeable.

V and H Coordinates Method

Denotes a method of computing airline miles between two points by utilizing the vertical and horizontal coordinates of the two points.

Wire Center

Denotes a building in which one or more central offices are located.

2.12 NATURAL DISASTER RELIEF FOR CUSTOMERS

In situations where customers' telecommunications services are interrupted by natural disasters, the Company may offer alternative telecommunications services to customers in the immediate affected area, and waive otherwise applicable charges for those services. The availability and details of the offers, including, but not limited to, the maximum duration of the offer or waiver of any applicable charges, will be determined by the Company in each instance of natural disaster.

(N)
—
(N)

Qwest Corporation
Private Line Transport Services
Catalog

State of North Dakota
Effective: 11-30-2006

SECTION 3
Index Page 1
Release 2

3. RATE CONDITIONS

SUBJECT	PAGE	
Administrative Changes	4	
Analog Private Line Transport Service Upgrades	21	
Channel Performance	2	
Competitive Response	24	(N)
Custom Service Arrangement	10	
Discount Pricing	13	
Fractional Rates	22	
Mileage Measurement	23	
Minimum Billing Period	22	
Moves	5	
Nonrecurring Charges	1	
Optional Features and Functions	3	
Rate Stabilized Pricing	10	
Recurring Rates	1	
Reestablishment of Service Following Fire, Flood, or Other Occurrence	6	
Rollover	7	
Service Guarantee - Provisioning.....	9	
Service Provisioning	1	
Service Rearrangements	3	
Transport Mileage	2	
Types of Charges	1	

Qwest Corporation
Private Line Transport Services
Catalog

State of North Dakota
Effective: 11-30-2007

SECTION 3
Page 1
Release 2

3. RATE CONDITIONS

3.1 GENERAL

This section contains specific terms and conditions governing the rates and charges for Private Line Transport Services. In addition, DS1 and DS3 Service have terms and conditions governing rates and charges that are different than and/or in addition to those specified following. (C)

3.2 TYPES OF CHARGES

There are two types of rates and charges. These are recurring rates and nonrecurring charges described as follows.

3.2.1 RECURRING RATES

Recurring rates are flat rates that apply each month or fraction thereof that Private Line Transport is provided. These rates may apply on a daily or monthly basis, depending on the type of service. For billing purposes, each month is considered to have 30 days.

3.2.2 NONRECURRING CHARGES

Nonrecurring charges are one-time charges that apply for a specific work activity. The types of nonrecurring charges that apply are: Service Provisioning Charge (Initial, and/or Subsequent or Same Wire Center), Channel Performance, Transport Mileage, Optional Features and Functions and Service Rearrangements. Special Construction charges as defined in 4.1.6, following, may also apply. Customers who order service under an Alternate Pricing Arrangement as defined in 3.2.4, following, may incur additional nonrecurring charges as identified in each individual case.

A. Initial Service Provisioning

The Initial Service Provisioning Charge applies toward the processing, engineering, and design functions per customer request, for work to be performed on one circuit or service. Requests for additional work to be performed on existing circuit(s) or service(s) will be billed an Initial Service Provisioning Charge.

Qwest Corporation
Private Line Transport Services
Catalog

State of North Dakota
Effective: 10-1-2001

SECTION 3
Page 2
Release 2

3. RATE CONDITIONS

3.2 TYPES OF CHARGES

3.2.2 NONRECURRING CHARGES (Cont'd)

B. Subsequent Service Provisioning

The Subsequent Service Provisioning Charge applies per circuit(s) or service(s) when:

- At the same time as the initial circuit or service is requested, a customer orders identical additional circuit(s) or service(s), due the same date, for the same type of service and exact NC/NCI combinations, at the same location(s).
- At the same time as a request for additional work on an existing circuit or service, a customer requests the same additional work to be performed on identical existing circuit(s) or service(s), due the same date, for the same type of service and exact NC/NCI combinations, at the same location(s).

C. Channel Performance

A nonrecurring charge applies for the installation of each Channel Performance and includes its predefined technical specifications and the facilities from the customer designated premises to the serving wire center.

D. Transport Mileage

A nonrecurring charge applies for the installation of Transport Mileage which provides the transmission facilities between wire centers.

(D)
(T)

(T)

Qwest Corporation
Private Line Transport Services
Catalog

State of North Dakota
Effective: 10-1-2001

SECTION 3
Page 3
Release 2

3. RATE CONDITIONS

3.2 TYPES OF CHARGES

3.2.2 NONRECURRING CHARGES (Cont'd)

E. Optional Features and Functions

(T)

Nonrecurring charges apply for the installation of some of the Optional Features and Functions available with Private Line Transport. The charge applies whether the feature or function is installed coincident with the initial installation of service or at any time subsequent to the installation of the service, unless otherwise specified.

F. Service Rearrangements

(T)

Service rearrangements are changes to existing (installed) services which do not result in either a change in the minimum billing period requirements or a change in the physical location of the Network Access Channel at a customer designated premises. The charge to the customer for the service rearrangement is dependent on whether the change is administrative only in nature or involves actual physical change to the service. Changes which result in the establishment of new minimum billing period obligations are treated as disconnects and new connects. Changes in the physical location of the Network Access Channel are treated as moves and are described in I., following.

Service rearrangements will be charged for as follows and the appropriate Service Provisioning Charge will apply in addition:

- If the change involves the addition of another leg to an existing service, the nonrecurring charge for the Channel Performance will apply. The charge will apply only for the leg that is being added.
- If the change involves the addition of an Optional Feature or Function which has a separate nonrecurring charge, that nonrecurring charge will apply.
- If the change involves changing the type of Channel Performance on a service, the Channel Performance nonrecurring charge will apply.
- If the change involves the changing of the type of service (e.g., a change from VG2 to VG3), it will be treated as a discontinuance of the existing service and the installation of a new service.

**Qwest Corporation
Private Line Transport Services
Catalog**

State of North Dakota
Effective: 04-19-2017

SECTION 3
Page 4
Release 4

3. RATE CONDITIONS

3.2 TYPES OF CHARGES

3.2.2 NONRECURRING CHARGES

F. Service Rearrangements (Cont'd)

- If the change involves changing jurisdiction from interstate to intrastate on End-Link or Mid-Link services, all nonrecurring charges will apply. This change will be treated as a discontinuance of the existing service and the installation of a new service.
- For all other changes, including the addition of Optional Features and Functions without separate nonrecurring charges, a charge equal to the Channel Performance nonrecurring charge associated with the facility will apply.

If the change involves reterminating an existing Voice Grade Service or Digital Data Service Network Access Channel onto a spare channel of a higher capacity service, only the Rollover nonrecurring charge, as specified in K., following, will apply.

G. Billable Administrative Changes

Some administrative changes are billable items to the customer. A Billable Administrative Charge will apply to the following, when requested by the customer.

- Change of customer circuit identification (circuit reference)
- Change of bill account number
- Supersedure. When a customer wishes to assume responsibility for a service which is already installed for another customer without any changes in the service, provided they meet the criteria established for a new customer.

A Billable Administrative Charge applies per service order.

	NONRECURRING CHARGE	(T)
• Billable Administrative Charge	\$12.00	(T)

Qwest Corporation
Private Line Transport Services
Catalog

State of North Dakota
Effective: 10-1-2001

SECTION 3
Page 5
Release 2

3. RATE CONDITIONS

3.2 TYPES OF CHARGES

3.2.2 NONRECURRING CHARGES (Cont'd)

H. Nonbillable Administrative Changes

(T)

Some administrative changes will be made without charge(s) to the customer. Such changes require the continued provision and billing of the Private Line Transport to the same entity (i.e., customer remains responsible for all outstanding indebtedness for the Private Line Transport).

Nonbillable Administrative changes are as follows:

- Change of customer name (i.e., the customer of record does not change but rather the customer of record changes its name--e.g., XYZ Company to XYZ Communications),
- Change of customer or customer's end user premises address when the change of address is not a result of a physical relocation of facilities,
- Change in billing data (name, address, or contact name or telephone number),
- Change of customer contact name or telephone number.

I. Moves

(T)

A move involves a change in the physical location of one of the following:

- The Point of Termination at the customer's designated premises
- The customer's premises

The charges for the move are dependent on whether the move is to a new location within the same building or to a different building.

Qwest Corporation
Private Line Transport Services
Catalog

State of North Dakota
Effective: 10-1-2001

SECTION 3
Page 6
Release 2

3. RATE CONDITIONS

3.2 TYPES OF CHARGES

3.2.2 NONRECURRING CHARGES

I. Moves (Cont'd)

(T)

1. Moves within the Same Building or Between Buildings on the Same Premises.

When the move is to a new location within the same premises or between buildings on the same premises, the move is the responsibility of the customer. There will be no change in the minimum billing period requirements.

2. Moves to a Different Building

Moves to a different building will be treated as a discontinuance and new installation of service and all associated nonrecurring charges will apply. New minimum period requirements will be established for the new services. The customer will also remain responsible for satisfying all outstanding minimum period charges for the discontinued service.

J. Reestablishment of Service Following Fire, Flood or Other Occurrence

(T)

1. Nonrecurring Charges do not Apply

Charges do not apply for the reestablishment of service following a fire, flood or other occurrence attributed to an Act of God provided that:

- The service is of the same type as was provided prior to the fire, flood or other occurrence.
- The service is for the same customer.
- The service is at the same location on the same premises.
- The reestablishment of service begins within 60 days after Company service is available. (The 60 day period may be extended a reasonable period if the renovation of the original location on the premises affected is not practical within the allotted time period).

Qwest Corporation
Private Line Transport Services
Catalog

State of North Dakota
Effective: 5-10-2004

SECTION 3
Page 7
Release 3

3. RATE CONDITIONS

3.2 TYPES OF CHARGES

3.2.2 NONRECURRING CHARGES

J. Reestablishment of Service Following Fire, Flood or Other Occurrence (Cont'd)

2. Nonrecurring Charges Apply

Nonrecurring Charges apply for establishing service at a different location on the same premises or at a different premises pending reestablishment of service at the original location.

K. Rollover

1. A rollover allows for a lower speed service (i.e., Voice Grade Service, Digital Data Service, or DS1 Service), to be either placed onto a higher speed service, or moved from one higher speed service to a different higher speed service or moved to a different channel on the same multiplexed service. (C)

Should the customer request to have work performed which involves the change of an:

- Existing Voice Grade Service (i.e., Standard or WATS) onto a multiplexed DS1 Service, or
- Existing Digital Data Service onto a multiplexed DS1 Service, or
- Existing DS1 Service onto a multiplexed DS3 Service (D)

and all of the following conditions are met, a rollover charge will apply to the lower speed service as specified in 2., following:

- The services are provided between the same customer locations as the original service(s), and
- All rollovers are performed at the same Company central office location, and
- All services involved in the rollover are provided by the Company.

Qwest Corporation
Private Line Transport Services
Catalog

State of North Dakota
Effective: 04-19-2017

SECTION 3
Page 8
Release 4

3. RATE CONDITIONS

3.2 TYPES OF CHARGES

3.2.2 NONRECURRING CHARGES

K. Rollover (Cont'd)

2. Rollover Charges

	NONRECURRING CHARGE	(T)
<ul style="list-style-type: none">• Rollover of existing Voice Grade Service onto a multiplexed DS1 Service, per service termination affected for either a two-wire or four-wire service		
<ul style="list-style-type: none"><ul style="list-style-type: none">- Standard Voice/WATS	\$193.00	(T)
<ul style="list-style-type: none">• Rollover of existing Digital Data Service onto a multiplexed DS1 Service, per service termination affected		
<ul style="list-style-type: none"><ul style="list-style-type: none">- 2.4, 4.8, 9.6, 19.2, 56, 64 kbps	219.00	(T)
<ul style="list-style-type: none">• Rollover of existing DS1 Service onto a multiplexed DS3 Service, per DS1 Service termination affected	325.00	(T)

Qwest Corporation
Private Line Transport Services
Catalog

State of North Dakota
Effective: 10-1-2001

SECTION 3
Page 9
Release 2

3. RATE CONDITIONS

3.2 TYPES OF CHARGES

3.2.2 NONRECURRING CHARGES (Cont'd)

L. Service Guarantee - Provisioning

(T)

The Company assures that all provisioning requests for Digital Data Service (DDS), DS1 and DS3 Service will be installed on the customer requested service date (due date) providing it is equal to or greater than the standard intervals published in the Service Interval Guide. If the Company fails to meet this commitment, the customer's bill will be adjusted to reflect a Service Guarantee credit of 100% of the total nonrecurring charge for the service. Service Guarantee applies to provisioning orders, with an application date on or after the effective date of this Catalog revision, for DDS, DS1 and DS3, which add, move, or change the Network Access Channel(s) or Channel Terminations, Transport Mileage, Channel Performance, and Optional Features and Functions, including service rearrangements. There is no additional charge for this guarantee. To be eligible for the Service Guarantee credit, the following conditions must be met.

1. The Service Guarantee - Provisioning conditions include:

- Service requests for DDS, DS1, and DS3 Service, excluding Free-Frame DS1 Service. This is limited to the nonrecurring charges for Channel Terminations, Channel Performance, Transport Mileage, Optional Features and Functions and the Service Provisioning Charge, if applicable.
- The Services must be provided wholly within Company territories.

2. The Service Guarantee - Provisioning Credit does not apply:

- To Service Date Changes or Design Changes due to customer reasons,
- To requests for Expedites, Cancellations, Additional Engineering, Additional Labor, Design Layout Report (DLR), Power Protection, Special Facilities Routing, Testing and any other Miscellaneous Changes specified in Section 4, preceding,
- During natural disasters or a declared national emergency, or where Priority Installation under the provisions for Telecommunications Service Priority take precedence,
- To Special Construction.
- To Free-Frame DS1 Service.

Qwest Corporation
Private Line Transport Services
Catalog

State of North Dakota
Effective: 3-9-2001

SECTION 3
Page 10
Release 1

3. RATE CONDITIONS

3.2 TYPES OF CHARGES (Cont'd)

3.2.3 CUSTOM SERVICE ARRANGEMENT

If the standard Channel Performance packages or available Optional Features and Functions are not adequate to meet a specific customer requirement, the customer may request and the Company may develop a unique Custom package where facilities and operating conditions permit. Both the monthly rate and the nonrecurring charges for the features will be developed on an individual case basis. The charges for all other rate categories as described in Section 5, following, will apply for the type of channel service requested. Special Construction Charges as defined in 4.1.6, following, may also apply.

3.2.4 RATE STABILIZED AND DISCOUNT PRICING

As an alternative to month-to-month Catalog rates, qualifying customers may elect a rate stabilized or discounted pricing arrangement. Rate stability allows eligible customers to have rate predictability for specified periods of time. Discounting allows eligible customers to realize some savings due to their larger volume of services and their long term commitment to that volume of services.

Each customer will be required to sign a contractual agreement for the furnishing of services on a rate stabilized or discounted pricing basis.

A. Rate Stability Terms and Conditions

1. Both Analog and Digital Data (DDS) Private Line Transport Services are eligible for rate stability consideration.
2. The rate stabilized price is the Catalog rate in effect at the time the agreement is signed by the customer.
3. The minimum contract value for Analog Private Line Transport Services is one thousand dollars (\$1,000.00) per month.

Qwest Corporation
Private Line Transport Services
Catalog

State of North Dakota
Effective: 3-9-2001

SECTION 3
Page 11
Release 1

3. RATE CONDITIONS

3.2 TYPES OF CHARGES

3.2.4 RATE STABILIZED AND DISCOUNT PRICING

A. Rate Stability Terms and Conditions (Cont'd)

4. No minimum contract value is required for Digital Data (DDS) Private Line Transport Services.
5. The only rate elements eligible for rate stabilization are: Network Access Channels (at Catalog rates), Channel Performance, Transport Mileage, and Private Line Transport Optional Features and Functions. These rate elements are the only ones to be used in the revenue calculation for determining eligibility.
6. In addition to satisfying the minimum eligibility requirements, the rate stabilized price must be above cost.
7. The nonrecurring charges, for circuit(s) installed under a rate stability plan, are not included under the contract and are those specified in the current Catalog.
8. When more than one Local Exchange Telephone Company (i.e., Qwest and another LEC) is involved in the provision of a service, Rate Stability and Discount Pricing apply only to the Network Access Channel, and Channel Performance and Signaling and Conditioning options which are provided in Qwest operating territory.
9. The contract period for both Analog and Digital Data Private Line Transport Services shall be not less than 12 months nor more than 84 months.

Qwest Corporation
Private Line Transport Services
Catalog

State of North Dakota
Effective: 3-9-2001

SECTION 3
Page 12
Release 1

3. RATE CONDITIONS

3.2 TYPES OF CHARGES

3.2.4 RATE STABILIZED AND DISCOUNT PRICING

A. Rate Stability Terms and Conditions (Cont'd)

10. Customers with service under a rate stability plan that is within 6 months of expiration may extend their rate stability plan rates for a period of 12 months, by notifying the Company in writing of their intent to do so. The 12 month extension will begin upon expiration of the existing rate stability plan. Extension of an existing rate stability plan is available only for the original customer of record of the service.

At the end of the rate stability plan or of the extension (whichever is applicable), the customer must choose to:

- Renew the service under a new rate stability plan,
- Continue service under the month-to-month option, or
- Discontinue the service.

If the customer renews the service, the monthly rates for a new rate stability plan will be the rates in effect, in the Catalog, on the renewable date. Should the customer not make a choice by the end of the existing rate stability plan or extension period, the rates will automatically revert to the month-to-month option.

11. A termination charge may apply if a customer falls below 80% of the billing level of the agreement. The termination charge is as specified in 2.4.6, preceding.

If a customer completely cancels all or a portion of the contracted service at any time during the term of the agreement, a termination charge may apply as specified in 2.4.6, preceding.

12. In any month, where the customer receives service generating a monthly billing amount greater than one hundred and twenty percent (120%) of the original contract billing level, the customer's contract billing level shall then increase to ninety percent (90%) of the new billing amount for the remainder of the term of the agreement. The minimum billing level will be eighty percent (80%) of the contract billing level.

Qwest Corporation
Private Line Transport Services
Catalog

State of North Dakota
Effective: 10-1-2001

SECTION 3
Page 13
Release 2

3. RATE CONDITIONS

3.2 TYPES OF CHARGES

3.2.4 RATE STABILIZED AND DISCOUNT PRICING (Cont'd)

B. Discount Pricing Terms and Conditions

Discount Pricing will be based on the length of the term of the agreement and the quantity of the circuits between the same two points. The two discounts, based on the term and the quantity, will be added together to determine the total discount. These standard discounts apply to all rate elements for Analog Private Line Transport and Digital Data Service except the Network Access Channel (NAC). A separate NAC discount structure is specified in 13.f., following.

(C)

1. Analog Private Line Transport Services and Digital Data Service are eligible for discount pricing consideration for Channel Performance, Transport Mileage, and Optional Features and Functions.
2. The discounted price is based on the Catalog rates in effect at the time the agreement is signed by the customer.
3. For Analog Service, the customer must have twenty-one (21) or more, two-wire equivalent circuits, between two points, or; the circuits to be included in the discount pricing agreement must have a minimum billing of five thousand (\$5,000.00) dollars per month, before discount.
4. For Digital Data Service, the circuits to be included in the discount pricing agreement must have a minimum billing of fifteen hundred (\$1,500.00) dollars per month, before discount, or the customer must subscribe to a contract period of 36 months, or longer.
5. In addition to satisfying the minimum eligibility requirements, the discounted price must be above cost.
6. The nonrecurring charges, for circuit(s) installed under a discount pricing agreement, are not included under the contract and are those specified in the current Catalog.
7. The contract period shall be not less than 12 months nor more than 84 months.

Qwest Corporation
Private Line Transport Services
Catalog

State of North Dakota
Effective: 3-9-2001

SECTION 3
Page 14
Release 1

3. RATE CONDITIONS

3.2 TYPES OF CHARGES

3.2.4 RATE STABILIZED AND DISCOUNT PRICING

B. Discount Pricing Terms and Conditions (Cont'd)

8. Customers with service under a discount pricing agreement that is within 6 months of expiration may extend their discount pricing agreement rates for a period of 12 months, by notifying the Company in writing of their intent to do so. The 12 month extension will begin upon expiration of the existing discount pricing agreement. Extension of an existing discount pricing agreement is available only for the original customer of record of the service.

At the end of the discount pricing agreement or of the extension (whichever is applicable), the customer must choose to:

- Renew the service under a new discount pricing agreement,
- Continue service under the month-to-month option, or
- Discontinue the service.

If the customer renews the service, the monthly rates for a new discount pricing agreement will be the rates in effect, in the Catalog, on the renewal date. Should the customer not make a choice by the end of the existing discount pricing agreement or extension period, the rates will automatically revert to the month-to-month option.

9. A termination charge may apply if a customer falls below 80% of the billing level of the agreement. The termination charge is as specified in 2.4.6, preceding.

If a customer completely cancels all or a portion of the contracted service at any time during the term of the agreement, a termination charge may apply as specified in 2.4.6, preceding.

10. In any month, where the customer receives service generating a monthly billing amount greater than one hundred and twenty percent (120%) of the original contract billing level, the customer's contract billing level shall then increase to ninety percent (90%) of the new billing amount for the remainder of the term of the agreement. The minimum billing level will be eighty percent (80%) of the contract billing level.

Qwest Corporation
Private Line Transport Services
Catalog

State of North Dakota
Effective: 3-9-2001

SECTION 3
Page 15
Release 1

3. RATE CONDITIONS

3.2 TYPES OF CHARGES

3.2.4 RATE STABILIZED AND DISCOUNT PRICING

B. Discount Pricing Terms and Conditions (Cont'd)

11. Analog Discount Schedule

The following discount schedule applies to only the following rate elements; Channel Performance, Transport Mileage, and Optional Features and Functions. The discounts are additive and will apply up to a maximum of 15%. Discounts may be less than those indicated to assure that rates are above costs.

	DISCOUNT
• Length of Agreement	
12 through 35 months	3%
36 through 59 months	10%
60 through 84 months	15%
(Plus)	
• Quantity of Circuits	
0 through 20	[1]
Over 20	5%

[1] Not eligible.

Qwest Corporation
Private Line Transport Services
Catalog

State of North Dakota
Effective: 10-1-2001

SECTION 3
Page 16
Release 2

3. RATE CONDITIONS

3.2 TYPES OF CHARGES

3.2.4 RATE STABILIZED AND DISCOUNT PRICING

B. Discount Pricing Terms and Conditions (Cont'd)

12. Digital Data Service Discount Schedule

The following discount schedule applies to only the following billing elements; Channel Performance, Transport Mileage, and Optional Features and Functions. The discounts are additive and will apply up to a maximum of 16%. Discounts may be less than those indicated to assure that charges are above cost.

	DISCOUNT
• Length of Agreement	
12 through 35 months	0%
36 through 59 months	5%
60 through 84 months	10%
(Plus)	
• Billing Amount	
\$0.00 to \$1,500.00	0%
\$1,500.00 to \$3,000.00, before discount	2%
\$3,000.00 to \$5,000.00, before discount	4%
over \$5,000.00, before discount	6%

13. Network Access Channel (NAC) Discount Pricing

Discount pricing for NACs is available to both Analog and Digital Data (DDS) Private Line Transport Services, and is determined based on the length of the term of the agreement, the quantity of NACs between two points (the same customer location and serving wire center), and if the equivalent two-wire quantity of NACs is greater than 50, the airline distance from the customer to the serving wire center. One 4-wire NAC is equivalent to two 2-wire NACs.

(C)

Analog and Digital Data Services are considered separately, when determining NAC discount eligibility and rates.

Qwest Corporation
Private Line Transport Services
Catalog

State of North Dakota
Effective: 04-19-2017

SECTION 3
Page 17
Release 3

3. RATE CONDITIONS

3.2 TYPES OF CHARGES

3.2.4 RATE STABILIZED AND DISCOUNT PRICING

B.13. (Cont'd)

- a. To be eligible for a discount on the NAC, the customer must have more than 50 two-wire equivalent NACs between a customer location and the serving wire center. Customers with 50 two-wire equivalent NACs or less will be charged the effective rate specified elsewhere in this Catalog.
- b. The rates for 1 to 50 equivalent two-wire NACs are specified in f., following.
- c. The rates for all two-wire equivalent NACs over 50 are developed on an individual case basis (ICB). The actual rate paid by the customer is determined by adding the specified rates for the first 50 NACs to the ICB price for all NACs over 50.
- d. The contract period for NAC Discount Pricing shall be not less than 12 months nor more than 84 months.
- e. NAC Discount Rate Elements

	MONTHLY RATE	(T)
• Discounted Network Access Channel		
- Two-Wire	[1]	(T)
- Four-Wire	[1]	(T)

[1] Monthly rates for discounted NACs will be specified in the Company Service Agreement.

Qwest Corporation
Private Line Transport Services
Catalog

State of North Dakota
Effective: 6-3-2005

SECTION 3
Page 18
Release 3

3. RATE CONDITIONS

3.2 TYPES OF CHARGES

3.2.4 RATE STABILIZED AND DISCOUNT PRICING

B.13. (Cont'd)

f. NAC Discount Schedule, per two-wire NAC[1]

NAC QUANTITY	MONTHLY RATE		
	12-35 MONTH TERM	36-59 MONTH TERM	60-84 MONTH TERM
• 1 to 50[2]	\$32.00 (I)	\$32.00 (I)	\$32.00 (I)

[1] The four-wire rate is double the two-wire rate.

[2] The rates for two-wire equivalent NACs over 50 are developed on an individual case basis (ICB).

NOTICE
THE INFORMATION CONTAINED IN THIS DOCUMENT IS SUBJECT TO CHANGE.

**Qwest Corporation
Private Line Transport Services
Catalog**

State of North Dakota
Effective: 10-1-2001

SECTION 3
Page 19
Release 2[1]

3. RATE CONDITIONS

3.2 TYPES OF CHARGES

3.2.4 RATE STABILIZED AND DISCOUNT PRICING (Cont'd)

(T)
(D)

[1] This page cancels Page 20, Release 1.

(C)

NOTICE
THE INFORMATION CONTAINED IN THIS DOCUMENT IS SUBJECT TO CHANGE.

**Qwest Corporation
Private Line Transport Services
Catalog**

State of North Dakota
Effective: 10-28-2018

SECTION 3
Page 21
Release 2

3. RATE CONDITIONS

3.2 TYPES OF CHARGES (Cont'd)

(D)
—
(D)

Qwest Corporation
Private Line Transport Services
Catalog

State of North Dakota
Effective: 3-9-2001

SECTION 3
Page 22
Release 1

3. RATE CONDITIONS

3.3 MINIMUM BILLING PERIOD AND FRACTIONAL RATES

- A. Rates for service offered under this Catalog are for a minimum billing period of one month or the length of time specified in a Custom Service Arrangement, a Rate Stabilized or Discount Pricing Arrangement or in specific service agreements.
- B. When a service is discontinued prior to the expiration of the minimum period, charges are applicable, whether the service is used or not, as follows:
 - When a service with a one month minimum period is discontinued prior to the expiration of the minimum period, a one month charge will apply at the rate level in effect at the time service is discontinued.
 - When a service with a minimum period greater than one month is discontinued prior to the expiration of the minimum period, a termination charge will apply as specified in 2.4.6, preceding.
- C. When the minimum billing period has been met, charges for a fraction of a month will be the monthly rate, prorated for the actual number of days service is furnished. For this purpose every month is considered to have 30 days.
- D. Fractions of a cent are carried throughout the computation of the charge. When the computed charge includes a fraction of a cent;
 - One-half cent or more is treated as one cent;
 - Less than one-half cent is disregarded
- E. The rates for service installed or changes in service which involve a change in rates will become effective on the day the service is installed or changed.

Qwest Corporation
Private Line Transport Services
Catalog

State of North Dakota
Effective: 3-9-2001

SECTION 3
Page 23
Release 1

3. RATE CONDITIONS

3.4 MILEAGE MEASUREMENT

The mileage to be used to determine the monthly rate for the Transport Mileage is calculated using the airline distance between wire centers. The serving wire center associated with a customer-designated premises is the serving wire center from which the customer-designated premises would normally obtain dial tone.

Transport Mileage is shown in terms of mileage bands. To determine the rate to be billed, first compute the mileage using the V&H coordinates method, as set forth in the National Exchange Carrier Association Tariff F.C.C. No. 4, then find the band into which the computed mileage falls and apply the rates shown for that band. When the calculation results in a fraction of a mile, always round up to the next whole mile before determining the mileage band and applying the rates.

When bridging locations are involved, mileage is computed and rates applied separately for each section of the Transport Mileage. When any service is routed through a wire center for purposes other than customer specified bridging (e.g., the Company chooses to so route for test access purposes), rates will be applied only to the distance calculated between the serving wire centers associated with the customer designated premises.

Qwest Corporation
Private Line Transport Services
Catalog

State of North Dakota
Effective: 11-30-2006

SECTION 3
Page 24
Release 1

3. RATE CONDITIONS

3.5 RESERVED FOR FUTURE USE

(N)

3.6 COMPETITIVE RESPONSE

A. Description

The Customer Incentive Program is an offering for potential new business and to existing business customers to induce the retention or continuation of existing services by those customers.

B. Terms and Conditions

1. This competitive response offering may be offered to potential new Qwest business customers. In addition, the Company may provide a retention benefit to any existing business customer who has retained a service for some period of time.
2. For potential new business customers, the Company will condition its offers upon a business customer remaining with the Company for a minimum of one year. Any minimum period of time shall be identified to the business customer as part of the offer. In such cases, if the customer terminates service early, they will be billed all of the nonrecurring charge(s) and monthly rate(s) waived under this program.
3. The recipients of the customer incentive offer and the amount of the customer incentive offer shall be in the sole discretion of the Company, but the value of the retention benefit may not exceed the sum of C.1., following.
4. The Company shall determine the particular details, including but not limited to periods and duration, class of customers, services, amounts, and geographic area, so long as each such offer to a particular business customer is not inconsistent with the provisions of this Catalog and the amount does not exceed the maximum amount set forth in C.1., following. The Company may prohibit use of this program in conjunction with another offer being marketed by the Company and/or a Company affiliate.

Qwest Corporation
Private Line Transport Services
Catalog

State of North Dakota
Effective: 11-30-2006

SECTION 3
Page 25
Release 1

3. RATE CONDITIONS

3.6 COMPETITIVE RESPONSE

(N)

B. Terms and Conditions(Cont'd)

5. Offers may differ based on reasonable criteria, including the following criteria or combinations of criteria below:
 - a. The sales channel through which the products are sold;
 - b. A specific geographic area;
 - c. Existing customers who request to have one or more products disconnected;
 - d. Customers who identify a better competitive offer available to them. Qwest representatives may present to these customers multiple offers up to the maximum value under this Catalog;
 - e. Such other facts, criteria, and circumstances as the Company believes are a reasonable basis upon which to distinguish among groups of customers;
 - f. The Company reserves the right to discontinue this offer.

Qwest Corporation
Private Line Transport Services
Catalog

State of North Dakota
Effective: 11-30-2006

SECTION 3
Page 26
Release 1

3. RATE CONDITIONS

3.6 COMPETITIVE RESPONSE (Cont'd)

(N)

C. Rates and Charges

1. Customers may be offered one of the following, or the equivalent monetary value, on selected products as determined by the Company:
 - a. A waiver of an amount up to 100% of the current business nonrecurring charge(s), or
 - b. A waiver of up to two months of the recurring rate(s), or
 - c. A waiver of an amount up to 100% of the current business nonrecurring charge(s) and up to two months of the recurring rate(s).
2. The waiver(s) will appear in the form of a credit(s) on the customer's bill. The waiver may be one-time, or spread over a period of up to 12 months in a fashion determined by the Company.
3. Waiver amounts are calculated on the first month's nonrecurring charge(s) and monthly rate(s). The total waived amount will not exceed the value of the total nonrecurring charge(s) plus two months service of the monthly rate(s).
4. In all cases, resellers who use the Customer Incentive Program shall be provided the maximum monetary equivalent of the program as allowed by this Catalog and can distribute that value to their end user customers in any manner that they choose. Further, resellers are not required to match the Company's program offers or timing in order to take advantage of the program, and no further wholesale discount is provided to the maximum monetary equivalent. Resellers shall be provided monetary equivalents and they shall not be provided merchandise, coupon offers, or the like.

Qwest Corporation
Private Line Transport Services
Catalog

State of North Dakota
Effective: 5-2-2016

SECTION 4
Index Page 1
Release 2

4. ORDER MODIFICATIONS AND MISCELLANEOUS CHARGES

SUBJECT	PAGE
Acceptance Testing	16
Additional Cooperative Acceptance Testing (ACAT)	17
Additional Engineering	12
Additional Labor	12
Avoidance	22
Billing Information.....	20
Cancellation of Application for Service	3
Command A Link - Network Reconfiguration Service.....	25
Critical Dates	3
Design Change	2
Design Layout Report (DLR)	8
Dispatch Charge	19
Diversity	22
Expedite	7
Facilities Protection-Special Facilities Routing.....	22
Maintaining Facilities	10
Maintenance of Service	10
Other Labor	13
Overtime Installation	12

(D)
(D)

Qwest Corporation
Private Line Transport Services
Catalog

State of North Dakota
Effective: 3-9-2001

SECTION 4
Index Page 2
Release 1

4. ORDER MODIFICATIONS AND MISCELLANEOUS CHARGES

SUBJECT	PAGE
Premises Work	11
Provision of Private Line Transport Billing Information - Carriers	20
Protection Service for High Voltage Environments.....	35
Repair of Facilities	10
Service Date Change	1
Special Construction	8
Testing Services	16
Additional Cooperative Acceptance Testing (ACAT)	17
Nonscheduled Testing (NST).....	17

Qwest Corporation
Private Line Transport Services
Catalog

State of North Dakota
Effective: 04-19-2017

SECTION 4
Page 1
Release 2

4. ORDER MODIFICATIONS AND MISCELLANEOUS CHARGES

4.1 GENERAL

The customer may request a modification of an order at any time prior to notification by the Company that service is available for the customer's use. The Company will make every effort to accommodate a requested modification when it is able to do so with the normal work force assigned to complete such an order within the normal business hours of 8 a.m. to 5 p.m.

If the modification cannot be made with the normal work force during normal business hours, the Company will notify the customer. If the customer still desires the order modification, the Company will schedule a new service date. Refer to the Service Interval Guide which is in accordance with Company procedures. All charges for order modifications will apply on a per-occurrence basis.

These order modifications do not apply to services not requiring a circuit provisioning design.

The types of order modifications available are delineated in the following paragraphs.

4.1.1 SERVICE DATE CHANGE

Service dates for the installation of new services or rearrangements of existing services may be changed, but the new service date may not exceed the original service date by more than 60 calendar days. (C)

When for any reason, the customer wishes to change the service date, the customer should notify the Company before the original service date, to request a different service date.

If the customer requested service date is more than 60 calendar days after the original service date, the order will be cancelled by the Company and reissued with the appropriate cancellation charges applied, unless the customer indicates that billing for the service is to commence, as specified in 4.1.3.A., following. Failure to notify the Company prior to the original service date to request a different service date may result in the application of a Dispatch Charge as set forth in 4.1.16, following. (C)

A new service date may be established that is prior to the original service date if the Company determines it can accommodate the customer's request without delaying service dates for orders of other customers.

Qwest Corporation
Private Line Transport Services
Catalog

State of North Dakota
Effective: 04-19-2017

SECTION 4
Page 2
Release 2

4. ORDER MODIFICATIONS AND MISCELLANEOUS CHARGES

4.1 GENERAL

4.1.1 SERVICE DATE CHANGE (Cont'd)

If the service is changed to an earlier date, the customer will be notified by the Company that an Expedited Order Charge will apply.

4.1.2 DESIGN CHANGE

The customer may request a design change to the service ordered. A design change is any change to an order which requires engineering review. An engineering review is a review by Company personnel of the service ordered and the requested changes to determine what change in the design, if any, is necessary to meet the changes requested by the customer. Design changes include such things as the addition or deletion of Optional Features or Functions or a change in the type of channel interface, or technical specification package. Design changes do not include a change of customer premises, or Private Line Transport type. Changes of this nature will require the issuance of a new order and the cancellation of the original order with appropriate cancellation charges applied.

The Design Change Charge will apply on a per order per occurrence basis for each order. If a change of service date is required, the Dispatch Charge as set forth in 4.1.16, may also apply.

	NONRECURRING CHARGE	(T)
• Design Change, per order	\$67.50	(T)

Qwest Corporation
Private Line Transport Services
Catalog

State of North Dakota
Effective: 04-19-2017

SECTION 4
Page 3
Release 2

4. ORDER MODIFICATIONS AND MISCELLANEOUS CHARGES

4.1 GENERAL (Cont'd)

4.1.3 CANCELLATION OF APPLICATION FOR SERVICE

- A. A customer may cancel an order for the installation of service at any time prior to notification by the Company that service is available for the customer's use. The cancellation date is the date the Company receives written or verbal notice from the customer that the order is to be canceled. If a customer or a customer's end user is unable to accept service within 30 calendar days after the latest agreed upon service date, the following will occur: (C)
- The order shall be canceled and charges as set forth in B. following will apply if the service has not been fully provisioned, or (C)
 - The Access Order will be completed and billing for the service will commence if the service has been fully provisioned or the customer has indicated that billing for the service should begin. (C)
(C)

- B. Certain Critical Dates as specified in C., following, are used by the Company to monitor the service order provisioning process. Cancellation charges are based on the estimated costs incurred by the Company at the time the order is canceled. The Company monitors which Critical Date was last scheduled and determines what percentage of the Company's provisioning costs have been incurred as of that Critical Date. A list of Critical Dates and the number of days between each date is found in the Service Interval Guide. (D)
(D)

Costs incurred in conjunction with the provision of Private Line Transport Service start on the Application Date as defined in C., following. When the customer cancels an order prior to the Application Date, no charges shall apply. When the customer cancels an order on or after the Application Date, a charge equal to the estimated costs incurred by the Company shall apply. Such charge is determined as specified in D. and E., following. When a customer cancels an order or part of an order, on or after the original Service Date, the Cancellation Charge will apply as set forth in D., and E., following.

Qwest Corporation
Private Line Transport Services
Catalog

State of North Dakota
Effective: 3-9-2001

SECTION 4
Page 4
Release 1

4. ORDER MODIFICATIONS AND MISCELLANEOUS CHARGES

4.1 GENERAL

4.1.3 CANCELLATION OF APPLICATION FOR SERVICE (Cont'd)

- C. The Critical Dates monitored by the Company for the purpose of calculating a Cancellation Charge are as follows:
- Application Date (APP): The date the customer provides a firm commitment and sufficient information to the Company for order placement. The APP Date is the date the Company enters the order into the Company's order distribution system(s). This is sometimes referred to as the order date.
 - Design Layout Report Date (DLRD): The date the Design Layout Report which contains the design for the service(s) ordered is forwarded to the customer.
 - Plant Test Date (PTD): The date acceptance testing is performed with the customer.
 - Service Date (DD): The date the service is due to be made available to the customer. This is sometimes referred to as the Due Date.
- D. The percentage of the total provisioning cost incurred by the Company at a particular Critical Date varies by the type of service as shown in E., following.

When a customer cancels an order, or part of an order, before the Service Date, the Company will calculate the Cancellation Charge by multiplying all the nonrecurring charges associated with the order, or that part of the order being canceled, by the percentage shown in E., following, based on the last monitored Critical Date which has occurred on the order. When a customer cancels an order, or part of an order, on or after the Service Date, 100% of the nonrecurring charges plus minimum billing period charges apply.

Nonrecurring charges associated with an order are used to calculate the Cancellation Charge even when nonrecurring charges are waived.

Analog Service orders where the Network Access Channel recurring rate element is not billed, will be assessed a Cancellation Charge based on the equivalent of one Channel Performance nonrecurring charge for the service.

Digital Data Service orders where the Network Access Channel recurring rate element is not billed, will be assessed a Cancellation Charge based on the equivalent of one Channel Performance nonrecurring charge for the service.

Qwest Corporation
Private Line Transport Services
Catalog

State of North Dakota
Effective: 5-10-2004

SECTION 4
Page 5
Release 2

4. ORDER MODIFICATIONS AND MISCELLANEOUS CHARGES

4.1 GENERAL

4.1.3 CANCELLATION OF APPLICATION FOR SERVICE (Cont'd)

E. The Critical Dates monitored by the Company are as follows:

	APP	DLRD	PTD	DD
	%	%	%	%
• Low Speed Data	13	44	77	[1]
• Voice Grade	13	44	77	[1]
• Audio	13	44	77	[1]
• Foreign Exchange	13	44	77	[1]
• Foreign Central Office	13	44	77	[1]
• Exchange Service Extensions[2]	13	44	77	[1]
• Telephone Answering Service[2]	13	44	77	[1]
• Digital Data Service	13	44	77	[1]
• DS1	10	48	81	[1]
• DS3	10	48	81	[1]

(D)

[1] Minimum billing period charges and 100% of the nonrecurring charges apply when an order or part of an order is canceled on or after the original Service Date.

[2] Critical Dates applicable only when provisioned on an interoffice basis.

Qwest Corporation
Private Line Transport Services
Catalog

State of North Dakota
Effective: 3-9-2001

SECTION 4
Page 6
Release 1

4. ORDER MODIFICATIONS AND MISCELLANEOUS CHARGES

4.1 GENERAL

4.1.3 CANCELLATION OF APPLICATION FOR SERVICE (Cont'd)

- F. When a customer cancels an order for the discontinuance of service, no charges apply for the cancellation.
- G. If the Company misses a service date, due to circumstances over which it has direct control (excluding, e.g., acts of God, governmental requirements, work stoppages and civil commotions), the customer may cancel an order without incurring cancellation charges.
- H. A request for cancellation after completion of an installation will be treated as a discontinuance of service.

Qwest Corporation
Private Line Transport Services
Catalog

State of North Dakota
Effective: 8-5-2004

SECTION 4
Page 7
Release 2

4. ORDER MODIFICATIONS AND MISCELLANEOUS CHARGES

4.1 GENERAL (Cont'd)

4.1.4 EXPEDITE

- A. Expedited Order Charges for Private Line Orders are set forth in the Access Service Price Schedule.
- B. If costs other than additional labor are to be incurred when an order is expedited, the Company will develop, determine and bill the customer such costs in accordance with the Special Construction terms and conditions as set forth in 4.1.6, following.

(C)
(C)
(D)
(T)

Qwest Corporation
Private Line Transport Services
Catalog

State of North Dakota
Effective: 04-19-2017

SECTION 4
Page 8
Release 2

4. ORDER MODIFICATIONS AND MISCELLANEOUS CHARGES

4.1 GENERAL (Cont'd)

4.1.5 DESIGN LAYOUT REPORT (DLR)

At the request of the customer, the Company will provide to the customer the make-up of the facilities and service. This information will be provided in the form of a Design Layout Report. A mechanized DLR will be data transmitted to the customer at no charge and will be reissued or updated whenever these facilities are materially changed. At the customer's request, additional copies of the mechanized DLR and all hard copies of the DLR will be provided and a charge will apply.

A DLR will only be provided on End-Link or Mid-Link Services.

	NONRECURRING CHARGE	(T)
• Additional mechanized copies	\$6.00	
• Hard copy report	9.25	(T)

4.1.6 SPECIAL CONSTRUCTION

A. General

The terms and conditions and rates and charges for Special Construction are determined in accordance with Company Practices.

All rates and charges quoted in other sections of this Catalog provide for the furnishing of service when suitable facilities are available or where the construction of the necessary facilities does not involve unusual costs.

B. Conditions for Special Construction

1. Special Construction is required when a customer requests service and one or more of the following conditions exist:
 - a. The facilities to provide services are not available and, at the request of the customer, the Company constructs facilities to provide the services for the customer and there is no other requirement for the facilities so constructed.

Qwest Corporation
Private Line Transport Services
Catalog

State of North Dakota
Effective: 3-9-2001

SECTION 4
Page 9
Release 1

4. ORDER MODIFICATIONS AND MISCELLANEOUS CHARGES

4.1 GENERAL

4.1.6 SPECIAL CONSTRUCTION

B.1. (Cont'd)

- b. At the request of the customer, the Company constructs facilities of a type other than that which they would normally furnish in order to provide services for the customer.
- c. In order to comply with requirements specified by the customer, construction by the Company involves a routing of facilities other than that which they would normally utilize to provide services for the customer.
- d. At the request of the customer, the Company constructs a greater quantity of facilities than that which they would otherwise construct in order to fulfill the customer's initial requirements for services.
- e. The facilities to provide services are not available and, at the request of the customer, the Company expedites construction of the facilities at greater expense than would otherwise be incurred.
- f. The facilities to provide services are not available and, at the request of the customer, the Company constructs temporary facilities to provide services for the period during which the permanent facilities are under construction.

C. Special Construction Agreements

1. Customers requiring Special Construction enter into Special Construction agreements with the Company. In doing so, the customer may incur any one or all of the following liabilities depending on the circumstances surrounding the special construction:
 - Maximum Termination Liability (MTL).
 - Nonrecurring Charge (NRC).
 - Excess Recurring Monthly Charge (RMC).
 - Annual Underutilization Liability (AUL).

Qwest Corporation
Private Line Transport Services
Catalog

State of North Dakota
Effective: 3-9-2001

SECTION 4
Page 10
Release 1

4. ORDER MODIFICATIONS AND MISCELLANEOUS CHARGES

4.1 GENERAL (Cont'd)

4.1.7 MAINTAINING FACILITIES

Maintaining of facilities is initiated and furnished by the Company and is generally performed during the normal business hours of 8 a.m. to 5 p.m. At a time agreeable to both the customer and the Company, facilities shall be available for maintenance purposes.

All ordinary expense of maintaining Company provided facilities and service is borne by the Company. No credit allowance will be made for the period during which service is interrupted for such purpose.

4.1.8 MAINTENANCE OF SERVICE

- A. When a customer reports trouble to the Company for clearance and no trouble is found in the Company's facilities, the customer shall be responsible for payment of a Maintenance of Service charge, as specified in 4.1.12.A, following. Maintenance of Service charges apply, per technician, for the period of time from when Company personnel are dispatched to an unattended Company building or to the customer's premises, to when the work is completed. A Dispatch Charge also applies, as specified in 4.1.16, following, when Company personnel are dispatched.

The customer shall be responsible for payment of a Maintenance of Service charge when the trouble is in equipment or communications systems provided by other than the Company, or in detariffed CPE provided by the Company. No charge will apply when the trouble is found in the Company's facilities or equipment.

- B. In addition, when a customer reports trouble within a quantity of services and circuits, but fails to identify the specific service and circuit which is experiencing trouble, a Maintenance of Service charge applies for the time spent by Company personnel to isolate the trouble.

Qwest Corporation
Private Line Transport Services
Catalog

State of North Dakota
Effective: 3-9-2001

SECTION 4
Page 11
Release 1

4. ORDER MODIFICATIONS AND MISCELLANEOUS CHARGES

4.1 GENERAL

4.1.8 MAINTENANCE OF SERVICE (Cont'd)

- C. Failure of Company personnel to find trouble in Company facilities will result in no charge if the trouble is actually in those facilities, but not discovered at the time. Maintenance of Service charges are applicable per technician as set forth in 4.1.12.A., following. A call-out of a Company employee at a time not consecutive with the employee's scheduled work period is subject to a minimum charge of four hours. No credit allowance will be applicable for the interruptions involved if the Maintenance of Service charge applies.

- D. Maintenance of Service Charges are billed to the customer of record, where the problem exists, except in cases where a maintenance contract has been purchased.

4.1.9 PREMISES WORK

Work requested by a customer to be performed beyond a demarcation point is not regulated. A customer has the option of requesting that the Company perform Premises Work.

4. ORDER MODIFICATIONS AND MISCELLANEOUS CHARGES

4.1 GENERAL (Cont'd)

4.1.10 ADDITIONAL ENGINEERING

Additional Engineering will be provided by the Company at the request of the customer only when:

- A customer requests additional technical information after the Company has already provided the technical information normally included on the Design Layout Report (DLR).
- Additional engineering time is incurred by the Company to engineer a customer's request for a Customized service.

The Company will notify the customer that additional engineering charges, as set forth in 4.1.12.B., following, will apply before any additional engineering is undertaken. Normal business hours are from Monday through Friday 8 a.m. to 5 p.m. Hours before 8 a.m. and after 5 p.m., Monday through Friday, and all of Saturdays are considered overtime.

4.1.11 ADDITIONAL LABOR

Additional labor is that labor requested by the customer on a given service and agreed to by the Company as set forth in A. and B., following. The Company will notify the customer that additional labor charges as set forth in 4.1.12.C., following, will apply before any additional labor is undertaken. Normal business hours are from Monday through Friday 8 a.m. to 5 p.m. Hours before 8 a.m. and after 5 p.m., Monday through Friday, and all of Saturdays are considered overtime. Sundays and Holidays are premium time.

A. Overtime Installation

Overtime installation is that Company installation effort outside of normal business hours.

**Qwest Corporation
Private Line Transport Services
Catalog**

State of North Dakota
Effective: 04-19-2017

SECTION 4
Page 13
Release 3

4. ORDER MODIFICATIONS AND MISCELLANEOUS CHARGES

4.1 GENERAL

4.1.11 ADDITIONAL LABOR (Cont'd)

B. Other Labor

Other Labor is that additional labor not included in A., preceding, and labor incurred to accommodate a specific customer request that involves only labor which is not covered by any other section of this Catalog. Other Labor also includes fine tuning circuits (per occurrence) to return them to the originally designated level even though the circuit has not degraded below the designated immediate action level.

C. Labor for the Configuration of Optical and/or Ethernet Services

Labor charges for the Configuration of Optical and/or Ethernet Services are not included in A. or B., preceding. This charge covers a specific customer request that involves only labor and is set forth in 4.1.12.C.3., following, and not covered in any other section of this Catalog.

4.1.12 MAINTENANCE OF SERVICE, ADDITIONAL ENGINEERING AND LABOR RATES AND CHARGES

A. Maintenance of Service

The charges for Maintenance of Service as defined in 4.1.8, preceding, are as follows:

MAINTENANCE OF SERVICE PERIODS	NONRECURRING CHARGE	(T)
• Basic time, per technician, each 1/2 hour or fraction thereof	\$24.50	(T)
• Overtime, per technician, each 1/2 hour or fraction thereof[1]	30.50	(T)
• Premium time, per technician, each 1/2 hour or fraction thereof[1]	36.50	(T)

[1] A call-out on a Company employee at a time not consecutive with the employees scheduled work period is subject to a minimum charge of four hours.

**Qwest Corporation
Private Line Transport Services
Catalog**

State of North Dakota
Effective: 04-19-2017

SECTION 4
Page 14
Release 3

4. ORDER MODIFICATIONS AND MISCELLANEOUS CHARGES

4.1 GENERAL

4.1.12 MAINTENANCE OF SERVICE, ADDITIONAL ENGINEERING AND LABOR RATES AND CHARGES (Cont'd)

B. Additional Engineering

The charges for Additional Engineering as defined in 4.1.10, preceding, are as follows:

ADDITIONAL ENGINEERING PERIODS	NONRECURRING CHARGE	(T)
• Basic time, per technician, each 1/2 hour or fraction thereof	\$24.75	(T)
• Overtime, per technician, each 1/2 hour or fraction thereof[1]	31.75	(T)

C. Additional Labor

The charges for Additional Labor as defined in 4.1.11, preceding, are as follows:

1. Installation

ADDITIONAL LABOR - INSTALLATION PERIODS	NONRECURRING CHARGE	(T)
• Overtime, per technician, each 1/2 hour or fraction thereof[1]	\$ 6.00	(T)
• Premium time, per technician, each 1/2 hour or fraction thereof[1]	11.75	(T)

[1] A call-out of a Company employee at a time not consecutive with the employee's scheduled work period is subject to a minimum charge of four hours.

Qwest Corporation
Private Line Transport Services
Catalog

State of North Dakota
Effective: 04-19-2017

SECTION 4
Page 15
Release 3

4. ORDER MODIFICATIONS AND MISCELLANEOUS CHARGES

4.1 GENERAL

4.1.12 MAINTENANCE OF SERVICE, ADDITIONAL ENGINEERING AND LABOR RATES AND CHARGES

C. Additional Labor (Cont'd)

2. Other Labor

ADDITIONAL LABOR - OTHER PERIODS	NONRECURRING CHARGE	(T)
• Basic time, per technician, each 1/2 hour or fraction thereof	\$17.50	(T)
• Overtime, per technician, each 1/2 hour or fraction thereof[1]	22.50	(T)
• Premium time, per technician, each 1/2 hour or fraction thereof[1]	27.50	(T)
3. Labor for the Configuration of Optical and/or Ethernet Services		
	NONRECURRING CHARGE	(T)
• Service Order Charge, per request	\$175.00	(T)

[1] A call-out of a Company employee at a time not consecutive with employee's scheduled work period is subject to a minimum charge of four hours.

Qwest Corporation
Private Line Transport Services
Catalog

State of North Dakota
Effective: 3-9-2001

SECTION 4
Page 16
Release 1

4. ORDER MODIFICATIONS AND MISCELLANEOUS CHARGES

4.1 GENERAL (Cont'd)

4.1.13 ACCEPTANCE TESTING

At no additional charge, the Company will, at the customer's request, schedule a mutually agreeable time to cooperatively test the following parameters at the time of installation:

- For Voice Grade analog services (except Voice Grade Basic), acceptance tests will include tests for loss, 3-tone slope, dc continuity, operational signaling, C-notched noise, and C-message noise when these parameters are applicable and specified in the order for service. Additionally, for Voice Grade Services, a balance (improved return loss) test will be made if the customer has ordered the improved return loss optional feature.
- For other analog services (i.e., Low-Speed Data, Audio) acceptance tests will include tests for the parameters applicable to the service and as specified in the order for service.
- For Voice Grade Basic Service, no cooperative testing is available.

In addition to the above tests, Additional Cooperative Acceptance Testing for Voice Grade Service to test other parameters, as described in 4.1.15.A., following, is available at the customer's request. All test results will be made available to the customer upon request.

4.1.14 TESTING SERVICES

Testing Services offered under this section of the Catalog are optional and subject to rates as set forth in 4.1.15, following. Other testing services provided by the Company in association with Private Line Transport are furnished at no additional charge. These other testing services are described in 4.1.13, preceding.

Testing services are normally provided by Company personnel at Company locations. However, provisions are made following for a customer to request Company personnel to perform testing services at the customer's premises.

The offering of Testing Services under this section of the Catalog is made subject to the availability of the necessary qualified personnel and test equipment at the various test locations mentioned.

The Company will, at the request of a customer, provide assistance in performing specific tests requested by the customer.

4. ORDER MODIFICATIONS AND MISCELLANEOUS CHARGES

4.1 GENERAL

4.1.14 TESTING SERVICES (Cont'd)

A. Additional Cooperative Acceptance Testing (ACAT)

When a customer provides a technician at its premises or at an End User's premises, with suitable test equipment to perform the required tests, the Company will provide a technician at its office for the purpose of conducting Additional Cooperative Acceptance Testing on Voice Grade Services. At the customer's request, the Company will provide a technician at the customer's premises or at the End User's premises. These tests may consist of the following:

- Attenuation Distortion (i.e., frequency response)
- Intermodulation Distortion (i.e., harmonic distortion)
- Phase Jitter
- Impulse Noise
- Envelope Delay Distortion
- Echo Control
- Frequency Shift

B. Nonscheduled Testing (NST)

When a customer provides a technician at its premises, with suitable test equipment to perform the required tests, the Company will provide a technician at its office for the purpose of conducting Nonscheduled Testing. At the customer's request, the Company will provide a technician at the customer's premises. Nonscheduled tests may consist of any tests, such as loss, noise, slope, or envelope delay which the customer may require.

C. Obligation of the Customer

When the customer subscribes to Testing Service as set forth in this section, the customer shall make the facilities to be tested available to the Company at times mutually agreed upon.

Qwest Corporation
Private Line Transport Services
Catalog

State of North Dakota
Effective: 04-19-2017

SECTION 4
Page 18
Release 2

4. ORDER MODIFICATIONS AND MISCELLANEOUS CHARGES

4.1 GENERAL (Cont'd)

4.1.15 TESTING RATES AND CHARGES

A. Additional Cooperative Acceptance Testing (ACAT)

	NONRECURRING CHARGE	(T)
• Basic time, per technician, each 1/2 hour or fraction thereof	\$17.50	(T)
• Overtime, per technician, each 1/2 hour or fraction thereof[1]	22.50	(T)
• Premium time, per technician, each 1/2 hour or fraction thereof[1]	27.50	(T)

B. Nonscheduled Testing (NST)

• Basic time, per technician, each 1/2 hour or fraction thereof	17.50	(T)
• Overtime, per technician, each 1/2 hour or fraction thereof[1]	22.50	(T)
• Premium time, per technician, each 1/2 hour or fraction thereof[1]	27.50	(T)

[1] A call-out of a Company employee at a time not consecutive with employee's scheduled work period is subject to a minimum charge of four hours.

Qwest Corporation
Private Line Transport Services
Catalog

State of North Dakota
Effective: 04-19-2017

SECTION 4
Page 19
Release 3

4. ORDER MODIFICATIONS AND MISCELLANEOUS CHARGES

4.1 GENERAL (Cont'd)

4.1.16 Dispatch Charge

The Company assesses Dispatch Charges when a technician(s) is dispatched. The charge applies in the following situations:

A. Service Date Change

One Dispatch Charge applies to all Private Line Transport Services contained in this Catalog. The charge applies if, for any reason, the customer requests a service date change but fails to notify the Company before the service date and a Company technician is dispatched to the customer's premises on the service date.

The Company accordingly will delay the start of service, change the service date and assess a Dispatch Charge. The charge will apply each time this situation occurs.

B. Maintenance of Service

One Dispatch Charge applies when one or more technicians are dispatched for Maintenance of Service and no trouble is found in the Company's facilities. If, after the initial repair visit, a repair ticket is still open and a technician(s) is dispatched again, another Dispatch Charge applies. The additional Dispatch Charge only applies if trouble is still not found in Company's facilities. Maintenance of Service charges apply for each technician.

C. Nonrecurring Charge

	Nonrecurring Charge	(T)
• Dispatch Charge, per occurrence	\$100.00	(T)

Qwest Corporation
Private Line Transport Services
Catalog

State of North Dakota
Effective: 5-2-2016

SECTION 4
Page 20
Release 2

4. ORDER MODIFICATIONS AND MISCELLANEOUS CHARGES

4.2 PROVISION OF PRIVATE LINE TRANSPORT BILLING INFORMATION-CARRIERS

- A. The customer will receive its monthly bills and Customer Service Records (CSRs) in a standard paper format at no charge. At the option of the customer, monthly bills and CSRs may be provided electronically, in lieu of the standard paper format at no charge. (C)
|
(C)

- B. At the option of the customer additional copies of the customer's monthly bill and/or CSR may be provided in standard paper or electronic for an additional charge (C)
|
(C)
|
(D)
|
(D)

- C. Upon acceptance by the Company of an order for electronic transmission, the Company will determine the period of time to implement the transmission of such material on an individual order basis. (T)

Qwest Corporation
Private Line Transport Services
Catalog

State of North Dakota
Effective: 5-2-2016

SECTION 4
Page 21
Release 2

4. ORDER MODIFICATIONS AND MISCELLANEOUS CHARGES

4.2 PROVISION OF PRIVATE LINE TRANSPORT BILLING INFORMATION-CARRIERS (Cont'd)

- D. The rates and charges for the provision of additional copies of of Private Line Transport Service Billing Information after the initial copy has been provided are as follows: (C)
(C)

	RATE	
1. Electronic Transmission of Billing Detail and/or Information to a Customer's Premises	ICB	(T) (T) (D)
2. Additional Copies of the Customer's Monthly Bill and/or CSR		
• Paper		
- Per request[1]	\$ 9.00	
- + per page	0.01	

(D)

(D)

[1] Applies for each bill and each CSR requested.

(D)

Qwest Corporation
Private Line Transport Services
Catalog

State of North Dakota
Effective: 9-18-2007

SECTION 4
Page 22
Release 2

4. ORDER MODIFICATIONS AND MISCELLANEOUS CHARGES

4.3 FACILITIES PROTECTION - SPECIAL FACILITIES ROUTING

A. Description

The services provided by the Company are over such routes and facilities as the Company may elect. Special Facility Routing is involved when, in order to comply with requirements specified by the customer, the Company provides Private Line Transport Services, LAN Switching Service (LSS) and Metro Optical Ethernet (MOE) in a manner which includes one or more of the following conditions:

(C)
(C)

1. Diversity

Diversity occurs when the service is provisioned over a primary route and secondary route over separate transmission facilities. The alternate routes must have a route separation of 25 feet or more. Diversity can be provided on the local loop (from the serving wire center to the subscriber location), or Interoffice Facilities (between wire centers).

2. Avoidance

Avoidance occurs when service is provisioned in a manner to avoid, or by-pass, a subscriber defined geographical location.

3. Diversity and Avoidance Options

The following is a description of the standard options available:

Loop Diversity

Provides a second route from the first utility vault outside of the serving wire center to the subscriber premises. The diversity will end at the last terminal prior to the subscriber's premises unless the subscriber provides for a separate entrance facility.

Interoffice Diversity

Provides a second route between the first utility vault outside the serving wire center and the first utility vault outside the remote wire center. This service applies only to Private Line Transport Service.

Avoidance

Geographical avoidance of a given point or wire center.

Qwest Corporation
Private Line Transport Services
Catalog

State of North Dakota
Effective: 3-9-2001

SECTION 4
Page 23
Release 1

4. ORDER MODIFICATIONS AND MISCELLANEOUS CHARGES

4.3 FACILITIES PROTECTION - SPECIAL FACILITIES ROUTING (Cont'd)

B. Terms and Conditions

1. Diversity and Avoidance are available on all Private Line Transport services and on the loop portion of certain Exchange Access services. Service is subject to availability of facilities. When facilities are not available Special Construction charges may be assessed.
2. The rates and charges for Special Facilities Routing are in addition to all other rates and charges that may be applicable to the service provided with Special Facilities Routing.
3. When a customer orders more than one Special Facilities Routing option, (e.g., Loop Diversity and Interoffice Diversity, or multipoint Loop Diversity, i.e. on more than one leg of a multipoint circuit), at the same time, for the same service, only one nonrecurring charge applies. This nonrecurring charge applies to both the primary and secondary route for each service or circuit.
4. Rate Elements applicable for other services with Special Facilities Routing apply on both the Primary Route and the Secondary Route. Special Construction charges may be applicable with Loop Diversity when Secondary Routes are not available.
5. The terms Primary and Secondary Route are not meant as a reference to quality or usage, but are used to designate separate routing.

Qwest Corporation
Private Line Transport Services
Catalog

State of North Dakota
Effective: 04-19-2017

SECTION 4
Page 24
Release 2

4. ORDER MODIFICATIONS AND MISCELLANEOUS CHARGES

4.3 FACILITIES PROTECTION - SPECIAL FACILITIES ROUTING (Cont'd)

C. Rates and Charges

The rates and charges for Loop and Interoffice Diversity, and Avoidance, are specified following.

Monthly rates and nonrecurring charges for Loop and Interoffice Diversity apply on a per termination or per circuit basis.

Monthly rates and nonrecurring charges for Avoidance apply on a per service basis.

The rates and charges specified are in addition to the rates and charges for the services using Diversity and Avoidance.

	NONRECURRING CHARGE[1]	MONTHLY RATE	(T)
• Loop Diversity, per point of termination			
- Primary Route	\$50.00	\$12.00	(T)
- Secondary Route	50.00	12.00	(T)
• Interoffice Diversity, per circuit			
- Primary Route	50.00	10.00	(T)
- Secondary Route	50.00	10.00	(T)
• Avoidance, per service, per occurrence	50.00	12.00	(T)

[1] Only one nonrecurring charge applies, per circuit or service, when more than one option is ordered for the same service, at the same time.

4. ORDER MODIFICATIONS AND MISCELLANEOUS CHARGES

4.4 COMMAND A LINK - NETWORK RECONFIGURATION SERVICE

A. Description

Command A Link Network Reconfiguration Service provides the customer with the ability to reconfigure or rearrange their network from their premises at their convenience. The typical Command A Link network consists of three components: the circuits, which are purchased elsewhere in this Catalog; the connection of these circuits to the Command A Link Digital Crossconnect System (DCS) ports; and the access to the network controller to rearrange the circuits. The customer must specify the appropriate Network Channel Interface (NCI) and Network Channel (NC) codes as specified in Technical Publication 77371.

B. Service Elements

1. Digital Crossconnect System (DCS) Ports

This element provides for the cross-connection between circuit terminations. Like circuits can only cross-connect to like circuits i.e., voice to voice, data to data, of like circuit design and transmission rates. Terminations are provided on the following ports:

DS0 Port

Provides for the termination of analog or digital circuits up to the 64 kbit/s speed.

DS1 Port

Provides for the termination of a 1.544 Mbit/s digital circuit.

DS3 Port

Provides for the termination of a 44.736 Mbit/s digital circuit.

Virtual Port

Provides for the interconnection of compatible circuits of two separate Command A Link customers, by their mutual consent.

Qwest Corporation
Private Line Transport Services
Catalog

State of North Dakota
Effective: 11-30-2007

SECTION 4
Page 26
Release 2

4. ORDER MODIFICATIONS AND MISCELLANEOUS CHARGES

4.4 COMMAND A LINK - NETWORK RECONFIGURATION SERVICE

B. Service Elements (Cont'd)

2. Network Controller

This element communicates customer commands to the DCS. Through these commands, customers are able to establish and rearrange the cross-connections between their circuit terminations.

3. Access Options

a. Web Based Access

Web Based Access is a URL interface which provides access to the Graphical User Interface (GUI). This website allows customers to view their circuits and to reconfigure their services.

b. Attendant Access

With this option, the customer calls a Company attendant who follows customer instructions to reconfigure the customer's Command A Link circuits. Attendant Access is only available during normal business hours (8:00 a.m. - 5:00 p.m., Monday through Friday). Customers requesting Attendant Access, outside of normal business hours, will be liable for Additional Labor Charges as specified in Section 13 of the Access Service Catalog, in addition to the Attendant Access nonrecurring charge.

(C)
—
(C)

**Qwest Corporation
Private Line Transport Services
Catalog**

State of North Dakota
Effective: 04-19-2017

SECTION 4
Page 27
Release 3

4. ORDER MODIFICATIONS AND MISCELLANEOUS CHARGES

4.4 COMMAND A LINK - NETWORK RECONFIGURATION SERVICE (Cont'd)

C. Service Information

SERVICE

(T)

Command A Link
Month-to Month

(T)

Qwest Corporation
Private Line Transport Services
Catalog

State of North Dakota
Effective: 3-9-2001

SECTION 4
Page 28
Release 1

4. ORDER MODIFICATIONS AND MISCELLANEOUS CHARGES

4.4 COMMAND A LINK - NETWORK RECONFIGURATION SERVICE (Cont'd)

D. Terms and Conditions

The terms, conditions and regulations specified herein apply in addition to those specified for DS1 and DS3 Service, and in Section 2 of this Catalog.

1. Provisioning

- a. Command A Link Service provides circuit termination cross-connections and the control of these cross-connections. It does not include the provisioning of circuits. Circuits are governed by their established terms and conditions.
- b. Cross-connection and control devices are located on suitable Company premises. Provisioning of Command A Link Service is subject to the availability of these devices.
- c. Both intraLATA and interLATA circuits may terminate on the same DCS, cross-connecting with like circuits, i.e., intraLATA to intraLATA and interLATA to interLATA.
- d. Circuits which terminate on a DCS must conform to Command A Link technology, as determined by the Company.
- e. When customers concur, the circuit(s) of one customer may be interconnected to the compatible circuit(s) of another customer using a virtual port.

E. Rate Conditions

1. Digital Crossconnect System (DCS) Ports

a. DS0, DS1 and DS3 Port Charges

A monthly and a nonrecurring charge apply to each circuit terminating on a DCS port.

b. Virtual Port Charge

When circuits of two or more Command A Link customers are interconnected using virtual ports, a nonrecurring charge to each customer applies to establish each virtual port.

Qwest Corporation
Private Line Transport Services
Catalog

State of North Dakota
Effective: 11-30-2007

SECTION 4
Page 29
Release 2

4. ORDER MODIFICATIONS AND MISCELLANEOUS CHARGES

4.4 COMMAND A LINK - NETWORK RECONFIGURATION SERVICE

E. Rate Conditions (Cont'd)

2. Access Options[1]

a. Web Based Access

There is no additional charge for customers who use Web Based Access.

b. Attendant Access

When a customer requests the Company to make changes on their behalf, a per-transaction charge applies. Examples of transactions include, but are not limited to the following:

- The performance of each reconfiguration activity, including connecting, disconnecting, or reconnecting each circuit segment. For example, the connection of one 9.6 kbit/s data circuit to another 9.6 kbit/s data circuit constitutes two (2) transactions.
- A customer requested change in the customer's security code.
- Establishing, changing, or removing each scheduled reservation activity.
- A change to each of a customer's symbolic names or aliases for their circuits.
- Each request for a Command A Link list or report.

(C)
—
(C)

[1] Customers who subscribe to Web Based Access may also choose to use the attendant option for execution of commands and/or changes. The per-transaction charge will apply.

(C)

Qwest Corporation
Private Line Transport Services
Catalog

State of North Dakota
Effective: 3-1-2006

SECTION 4
Page 30
Release 2

4. ORDER MODIFICATIONS AND MISCELLANEOUS CHARGES

4.4 COMMAND A LINK - NETWORK RECONFIGURATION SERVICE

E. Rate Conditions (Cont'd)

3. Payment Options

- a. Command A Link is offered on a month-to-month basis, as described under DS1 Service. (C)
- b. Discount pricing is offered, based on volume. Volume discounts apply to month-to-month. (C)
(C)

The volume discount is applied in a tiered structure, i.e., if a customer purchases 15 Ports at the DS0 or DS1 level, the first ten will be at one price for each Port, while the next five will be at another (discounted) price for each Port. For DS3 Ports, the first Port will be at one price and each additional DS3 Port will be discounted. (T)

- c. The charges for service are for a minimum billing period of one month. (D)
(C)

4. Service Rearrangements (T)(M)

Should the customer choose to upgrade from a point-to-point DS0, DS1 or DS3 Service to a DS0, DS1 or DS3 provisioned with Command A Link, the appropriate Command A Link port nonrecurring charge will apply, in addition to the applicable nonrecurring charge(s) for the service rearranged. (M)

(M) Material moved from Page 32.

NOTICE
THE INFORMATION CONTAINED IN THIS DOCUMENT IS SUBJECT TO CHANGE.

Qwest Corporation
Private Line Transport Services
Catalog

State of North Dakota
Effective: 04-19-2017

SECTION 4
Page 31
Release 3

4. ORDER MODIFICATIONS AND MISCELLANEOUS CHARGES

4.4 COMMAND A LINK - NETWORK RECONFIGURATION SERVICE

F. Rates and Charges

1. Digital Crossconnect System Ports

a. Monthly Rates, per port

	MONTH TO MONTH	(T)
• DS0 Ports		
- 1-10	\$ 30.00	(T)
- 11-50	27.00	
- 51-100	25.00	
- More than 100	24.00	(T)
• DS1 Ports		
- 1-10	145.00	(T)
- 11-50	125.00	
- 51-100	110.00	
- More than 100	95.00	(T)
• DS3 Ports		
- First	1,525.00	(T)
- Each additional	1,235.00	(T)

Qwest Corporation
Private Line Transport Services
Catalog

State of North Dakota
 Effective: 04-19-2017

SECTION 4
 Page 32
 Release 4[1]

4. ORDER MODIFICATIONS AND MISCELLANEOUS CHARGES

4.4 COMMAND A LINK - NETWORK RECONFIGURATION SERVICE

F.1. (Cont'd)

b. Nonrecurring Charges, per port

	NONRECURRING CHARGE	
• DS0 Port	\$ 25.00	(T)
• DS1 Port	425.00	
• DS3 Port	500.00	
• Virtual Port	15.00	(T)
	NONRECURRING CHARGE	MONTHLY RATE
2. Access Option		
• Attendant Access, per transaction	\$30.00	– (T)

[1] This page cancels the following page: Pages 33 and 34, Release 1.

4. ORDER MODIFICATIONS AND MISCELLANEOUS CHARGES

4.5 PROTECTION SERVICE FOR HIGH VOLTAGE ENVIRONMENTS

A. Description[1]

1. Company services provided on facilities that extend to a high voltage environment, i.e., electric power generating, switching and distributing locations, require high voltage protection whenever hazardous voltages of 1000V peak-asymmetrical or greater appear on those facilities due to Ground Potential Rise (GPR) and/or induction caused by faults in electric power system(s) located on the customer's premises. The high voltage protection may be provided by the Company, as specified herein, or the customer may elect to provide the high voltage protection. The high voltage protection is designated to isolate or neutralize the hazardous voltages. The protection objectives on Company services and facilities at these locations are as follows:
 - To minimize electrical hazards to personnel engaged in construction, operation, maintenance and use of telecommunications service.
 - To limit electrical damage to telecommunications equipment, cable and wire facilities.
 - To provide the required service continuity and integrity of telecommunications transmission as specified by the customer.
2. This offering requires high voltage protection at the customer's premises and at the Company CO whenever the fault-produced GPR/induction equals or exceeds 1000V peak-asymmetrical.

[1] High Voltage Protection, as specified herein, does not apply to services provided on fiber optic facilities.

Qwest Corporation
Private Line Transport Services
Catalog

State of North Dakota
Effective: 3-9-2001

SECTION 4
Page 36
Release 1

4. ORDER MODIFICATIONS AND MISCELLANEOUS CHARGES

4.5 PROTECTION SERVICE FOR HIGH VOLTAGE ENVIRONMENTS (Cont'd)

B. Responsibility of the Customer

1. A customer whose Company services are provided on facilities that extend to a high voltage environment where high voltage protection is required, as set forth in A., preceding, shall be responsible for providing to the Company a completed Form RG 31-0048, "Design Information for Power Industry Channels," which includes the following:
 - a. The maximum return (line fault) current under worst case single-phase fault conditions at each location where telecommunications services are requested.
 - b. The type, quantity and projected forecast of each service required at a given location, including those required by contractors or any other temporary service needs, in accordance with the definitions given in D., following.
 - c. The Service Performance Objective Classification for each service in accordance with the definitions in E., following.
 - d. The technical data needed by the Company to determine the method of protection required at each service location. This data includes, but is not limited to, the ground grid area, impedance of the station ground grid to remote earth, X/R ratio of the power system at the probable point of fault, fault current diagrams and maps of major power feeder routes.
2. Changes in the information provided in 1., preceding, will require written notification, with a revised Form RG 31-0048. These changes shall be provided as they occur to permit reevaluation, redesign, implementation and tests of the required modified or new protection method.

Qwest Corporation
Private Line Transport Services
Catalog

State of North Dakota
Effective: 3-9-2001

SECTION 4
Page 37
Release 1

4. ORDER MODIFICATIONS AND MISCELLANEOUS CHARGES

4.5 PROTECTION SERVICE FOR HIGH VOLTAGE ENVIRONMENTS (Cont'd)

C. Responsibility of the Company

1. The Company, working in conjunction with the customer, shall determine the proper methods of protection required to achieve the objectives set forth in A. The method of protection for every service in a cable shall be coordinated by the Company to be compatible with the protection provided for the most critically important service in that cable.
2. It is expressly declared that metallic facilities are in continually decreasing supply, and the Company is not obligated to continue to make such facilities available. Metallic facilities are offered only where existing facilities and operating conditions permit.
3. The Company reserves the right to treat high voltage protection on an individual case basis, dependent on the type of facilities available.

Qwest Corporation
Private Line Transport Services
Catalog

State of North Dakota
Effective: 3-9-2001

SECTION 4
Page 38
Release 1

4. ORDER MODIFICATIONS AND MISCELLANEOUS CHARGES

4.5 PROTECTION SERVICE FOR HIGH VOLTAGE ENVIRONMENTS (Cont'd)

D. Protection Service Types

1. Protection services which the Company offers are identified according to the following types:

Type 1

Services requiring either dc transmission or ac and dc transmission, used for basic exchange telephone service and/or Private Line Transport Service.

Type 2

Private Line Transport Service requiring Voice Grade and/or Low Speed Data, D.C. Channel and Alarm transmission, used for pilot wire protective relaying or dc tripping.

Type 3

Private Line Transport Service requiring ac Voice Grade transmission only, used for telemetering, supervisory control, data, etc.

Type 4

Private Line Transport Service requiring ac Voice Grade transmission only, used for audio tone protective relaying.

E. Service Performance Objective Classification

1. Interruptions or outages of telecommunications circuits serving electric power substations may occur for physical reasons such as cable damage due to extraordinarily heavy storm loading, a vehicle striking and breaking a utility pole, a cable cut, a lightning strike, or acts of God. Circuit failures caused by such events cannot be prevented and the Company expressly states that provision of the service provided in this section cannot preclude such service outages as may occur due to the above mentioned circumstances.
2. Interruptions or outages due to the effect (GPR and/or induction) of faults in the customer's power generating, transmission and/or distribution systems are minimized through the installation and maintenance of high voltage protection service which is designed to operate in a fault-produced electrical environment.

4. ORDER MODIFICATIONS AND MISCELLANEOUS CHARGES

4.5 PROTECTION SERVICE FOR HIGH VOLTAGE ENVIRONMENTS

E. Service Performance Objective Classification (Cont'd)

3. Because of the customer's need for service continuity during power system faults on some types of telecommunications services provided to power stations, the following system of Service Performance Objective Classifications has been established for the purpose of permitting the customer to specify the performance objectives for most types of telecommunications services provided to power stations:

a. Class A

Non-interruptible service performance (must function before, during and after the power fault condition) for services requiring ac transmission only. Class A service cannot tolerate even a momentary service interruption. Non-tolerable service interruptions include both loss of dependability (failure to deliver a valid trip or control signal) and loss of security (delivery of a false trip or control signal).

b. Class B

Self-restoring interruptible service performance (must function before and after the power fault condition) for any service. Class B service can tolerate a service interruption for the duration of a power system fault, but service continuity must be restored immediately after the fault without requiring any repair personnel activity.

c. Class C

Interruptible service performance (can tolerate a station visit to restore service) for power stations with a GPR less than 1000V peak-asymmetrical. Class C service can tolerate a service interruption which requires a station visit by repair personnel to restore service. Class C service cannot be provided in conjunction with Class A or Class B service.

Qwest Corporation
Private Line Transport Services
Catalog

State of North Dakota
Effective: 3-9-2001

SECTION 4
Page 40
Release 1

4. ORDER MODIFICATIONS AND MISCELLANEOUS CHARGES

4.5 PROTECTION SERVICE FOR HIGH VOLTAGE ENVIRONMENTS (Cont'd)

F. Provision of High Voltage Protection Service

1. The Company or the customer may provide the high voltage protection.
2. At the customer's request, the Company shall provide any required high voltage protection at the customer's premises and, if necessary, at the Company's CO at rates and charges set forth in G., following. The Company will inspect and verify the protection when service is established at new or existing customer locations and at future times as deemed necessary during changes, rearrangements or maintenance.
3. If the customer elects to provide the required high voltage protection, the equipment used must meet the technical requirements specified in the Institute of Electrical and Electronics Engineers (IEEE) Standard 487.
4. Where the Company does not provide the high voltage protection (HVP) on the customers facilities because the customer has elected to select, install, use and maintain its own HVP, the customer does so with the understanding that it is solely responsible for any interruption of Company service associated with its selection, installation, use or maintenance of the HVP. Furthermore, the customer, its successors and assigns, agree to indemnify and hold the Company and its Subsidiaries and its and their employees, officers, directors and agents harmless from all loss, liabilities, costs and expenses, including attorneys' fees and all cost of defense and settlement, resulting from interruption of service, damage to Company property, claims, demands, suits or actions of any nature whatsoever ("Proceedings"), arising from the failure of the HVP selected, installed, used or maintained by the customer.
5. The Company reserves the right to suspend any service without adequate high voltage protection until adequate protection is provided.

Qwest Corporation
Private Line Transport Services
Catalog

State of North Dakota
 Effective: 04-19-2017

SECTION 4
 Page 41
 Release 2

4. ORDER MODIFICATIONS AND MISCELLANEOUS CHARGES

4.5 PROTECTION SERVICE FOR HIGH VOLTAGE ENVIRONMENTS (Cont'd)

G. Rates and Charges

1. Protection Service Types[1]

These rates and charges apply for each service terminated and treated with high voltage protection at a service location. These rates and charges do not include equipment cabinets or mounting arrangements which may be provided by the Company at additional costs or by the customer.

	NONRECURRING CHARGE	MONTHLY RATE	(T)
• Type 1 Class B Service			
- 2 wire	\$136.00	\$28.60	(T)
- 4 wire-metallic[2]	170.00	41.20	
- 4 wire-non-metallic	170.00	41.20	(T)
• Type 2 Class B Service			
- 2 wire	195.00	48.70	(T)
- 4 wire[2]	289.00	97.40	(T)
• Type 3 Class A Service			
- 2 wire	195.00	28.90	(T)
- 4 wire	289.00	57.80	(T)
• Type 3 Class B Service			
- 2 wire	136.00	20.60	(T)
- 4 wire	170.00	41.20	(T)
• Type 4 Class A Service			
- 2 wire	195.00	28.90	(T)
- 4 wire	289.00	57.80	(T)

[1] These rates and charges are in addition to charges for Local Exchange Telephone Service and/or the Network Access Channel, Channel Performance and Transport Channels which are applicable for Low Speed Data, D.C. Channel, Alarm and Voice Grade channels.

[2] Service is limited to a maximum ground potential rise of 4.0 KV RMS-11VS.

Qwest Corporation
Private Line Transport Services
Catalog

State of North Dakota
Effective: 3-9-2001

SECTION 4
Page 42
Release 1

4. ORDER MODIFICATIONS AND MISCELLANEOUS CHARGES

4.5 PROTECTION SERVICE FOR HIGH VOLTAGE ENVIRONMENTS

G. Rates and Charges (Cont'd)

2. In lieu of the nonrecurring charges and the monthly rates specified in 1., preceding, the customer may elect to pay an upfront, nonrecurring charge for high voltage protection service to be provided by the Company for a period of up to ten years. This nonrecurring charge will be determined on an individual case basis (ICB), with payment terms and conditions specified in a service agreement between the Company and the customer. At the end of the service period, a new service agreement may be negotiated for the continued maintenance of the high voltage protection service, or the service may be continued on a month-to-month basis.

**Qwest Corporation
Private Line Transport Services
Catalog**

State of North Dakota
Effective: 3-9-2001

SECTION 104
Index Page 1
Release 1

**104. OBSOLETE ORDER MODIFICATIONS AND
MISCELLANEOUS CHARGES**

SUBJECT	PAGE
High Voltage Environment Protection Arrangement.....	1

**Qwest Corporation
Private Line Transport Services
Catalog**

SECTION 104

State of North Dakota
Effective: 3-9-2001

Page 1
Release 1

**104. OBSOLETE ORDER MODIFICATIONS AND
MISCELLANEOUS CHARGES**

104.5 HIGH VOLTAGE ENVIRONMENT PROTECTION ARRANGEMENT

Company services extending to electric power generating and distributing locations may require special equipment to isolate or neutralize the environmental hazards experienced when ground potentials rise due to faults in the electric power system. The customer is responsible for conditioning the environment to eliminate hazardous voltages due to ground potential rises.

The Company shall determine the proper levels of protection to isolate or neutralize the electrical hazard and will provide, if necessary, the equipment to perform this function.

The customer may elect to furnish the equipment required to neutralize electrical hazards subject to the approval by the Company of the proper levels of protection and the equipment provided by the customer.

A. Rates and Charges

The following charges are applicable for high voltage protection devices furnished by the Company and do not include equipment cabinets or mounting arrangements which may be provided by either the customer or the Company at additional costs.

	USOC	INSTALLATION CHARGE	MONTHLY RATE
1. Neutralizing protection suitable for exchange and private line service requiring direct current transmission.			
a. Up to 2500 volt, steady drain voltage			
• Single Channel Units, interior or exterior mounted, each[1]	PJX	\$100.00	\$9.00

[1] Four-wire channels require two units per termination.

**Qwest Corporation
Private Line Transport Services
Catalog**

State of North Dakota
Effective: 10-1-2001

SECTION 104
Page 2
Release 2

**104. OBSOLETE ORDER MODIFICATIONS AND
MISCELLANEOUS CHARGES**

104.5 HIGH VOLTAGE ENVIRONMENT PROTECTION ARRANGEMENT

A.1. (Cont'd)

	USOC	INSTALLATION CHARGE	MONTHLY RATE
b. Up to 400 volt, steady drain voltage			
• Single Channel Units, interior or exterior mounted, each[1]	PJX	\$100.00	\$9.00

(D)

[1] Four-wire channels require two units per termination.

Qwest Corporation d/b/a CenturyLink QC
Private Line Transport Services
Catalog

State of North Dakota
Effective: 12-01-2020

SECTION 5
Index Page 1
Release 3

5. SERVICES

SUBJECT	PAGE	
Audio Service– GRANDFATHERED	26	(C)
Diagrams		
Multipoint	8	
Two-Point Service.....	6	
Digital Data Service (DDS) – GRANDFATHERED	38	(C)
DS1 Service	43	
DS3 Service	63	
Exchange Service Extensions (Non-PBX)	34	
Facility Hubs.....	10	
Foreign Central Office Service	32	
Foreign Exchange Service	29	
General.....	1	
Low-Speed Data Service– GRANDFATHERED	12	(C)
Rate Categories	4	
Service Configurations	6	
Service Descriptions.....	12	
Service Rearrangement Charge.....	56	
Service Types.....	1	
Shared Use	11	
Telephone Answering Service	35	
Voice Grade Service – GRANDFATHERED	17	(C)

Qwest Corporation d/b/a CenturyLink QC
Private Line Transport Services
Catalog

State of North Dakota
Effective: 12-01-2020

SECTION 5
Page 1
Release 2

5. SERVICES

5.1 GENERAL

This section contains specific regulations governing Private Line Transport Services. In addition, DS1 and DS3 Service and Command A Link have regulations governing rates and charges that are different than and/or in addition to those specified following.

Private Line Transport provides a transmission path between customer designated premises or customer designated premises and a Serving Wire Center. Company Centrex CO-like switches are considered to be customer-designated premises for purposes of administering and providing Private Line Transport.

5.1.1 SERVICE TYPES

There are several types of services used to provide Private Line Transport. Each type has its own characteristics. All are subdivided by one or more of the following:

- Transmission specifications
- Bandwidth
- Speed (i.e., bit rate)

Customers can order a basic channel and select from a list of available transmission performance and channel interfaces, those that they desire to meet specific communications requirements.

For purposes of ordering channels, each has been identified as a type of Private Line Transport. However, such identification is not intended to limit a customer's use of the channel nor to imply that the channel is limited to a particular use.

Following is a brief description of each type of service:

Low Speed Data [1] (C)

A channel for the transmission of low speed loop status signals of up to 150 baud and for the transmission of McCulloh type alarm signals

Voice Grade [1] (C)

A channel for the transmission of analog signals within an approximate bandwidth of 300-3000 Hz.

^[1] **Effective December 1, 2020 Low Speed Data, Voice Grade, Audio, and Digital Data Services are grandfathered. Availability to current customers is limited to circuits in service at existing locations.** (N)
|
(N)

Qwest Corporation d/b/a CenturyLink QC
Private Line Transport Services
Catalog

State of North Dakota
Effective: 12-01-2020

SECTION 5
Page 2
Release 2

5. SERVICES

5.1 GENERAL

5.1.1 SERVICE TYPES (Cont'd)

Audio – [1]

(T)

A channel for the transmission of audio signals. The nominal frequency bandwidths are from 200 to 3,500 Hz, from 100 to 5,000 Hz, from 50 to 8,000 Hz or from 50 to 15,000 Hz. Audio multipoint private line channels are specially provided for the closed circuit (nonbroadcast) transmission of voice and music in one direction only.

Foreign Exchange (FX)

Provides dial tone from a wire center in an exchange from which the customer is not normally served.

Foreign Central Office (FCO)

Provides dial tone from a serving wire center to a remote wire center in the same exchange.

Exchange Service Extension (ESE)

Channel which extends dial tone from a customer's serving wire center to a noncontinuous property station location.

^[1] **Effective December 1, 2020 Low Speed Data, Voice Grade, Audio, and Digital Data Services are grandfathered. Availability to current customers is limited to circuits in service at existing locations.**

(N)
|
(N)

Qwest Corporation d/b/a CenturyLink QC
Private Line Transport Services
Catalog

State of North Dakota
Effective: 12-01-2020

SECTION 5
Page 3
Release 3

5. SERVICES

5.1 GENERAL

5.1.1 SERVICE TYPES (Cont'd)

Telephone Answering Service (TAS)

Channel from a patron's central office to the Answering Bureau.

Digital Data [1]

(C)

A channel for the digital transmission of synchronous serial data at rates of 2.4, 4.8, 9.6, 19.2, 56 and 64 kbps.

DS1

A channel for point-to-point digital facilities for two-way transmission at a speed of 1.544 Mbps.

DS3

A channel for point-to-point, two-way high speed digital transmission at 45 Mbps.

^[1] **Effective December 1, 2020 Low Speed Data, Voice Grade, Audio, and Digital Data Services are grandfathered. Availability to current customers is limited to circuits in service at existing locations.**

(N)
|
(N)

ND2020-13

Qwest Corporation
Private Line Transport Services
Catalog

State of North Dakota
Effective: 3-9-2001

SECTION 5
Page 4
Release 1

5. SERVICES

5.1 GENERAL (Cont'd)

5.1.2 RATE CATEGORIES

There are four basic rate categories which apply to Private Line Transport:

- Network Access Channel
- Channel Performance
- Transport Mileage
- Optional Features and Functions

A. Network Access Channel

The Network Access Channel provides a two-wire or four-wire communications path between the POT and the normal serving wire center of that premises. One Network Access Channel charge applies per channel terminated at the POT. This charge will apply even if the customer-designated premises and the serving wire center are collocated in the same building. On certain services, the Network Access Channel may be derived from an existing service.

B. Channel Performance

The Channel Performance provides the electronic equipment which is added to the Network Access Channel to provide the desired level of transmission performance. It modifies the circuit with the basic performance necessary for the circuit to function. If appropriate, it may also provide various signaling parameters to enhance the basic performance. Included as part of the Channel Performance is a Network Channel Interface (NCI) or POT arrangement which defines the technical characteristics at the interface between the customer and the Company. One Channel Performance charge will apply per Network Access Channel.

C. Transport Mileage

The Transport Mileage provides for the transmission facilities between the serving wire centers associated with two customer-designated premises. The Transport Mileage is portrayed in mileage bands. There are two rate elements that apply for each band, a flat rate per band and a rate per mile. Transport Mileage is measured by airline miles between serving wire centers via the V and H Coordinates Method, as set forth in the National Exchange Carrier Association Tariff F.C.C. No. 4.

Qwest Corporation
Private Line Transport Services
Catalog

State of North Dakota
Effective: 3-9-2001

SECTION 5
Page 5
Release 1

5. SERVICES

5.1 GENERAL

5.1.2 RATE CATEGORIES (Cont'd)

D. Optional Features and Functions

The Optional Features and Functions rate category provides for optional features and functions which may be added to Private Line Transport to improve its quality or utility to meet specific communications requirements. These are not necessarily identifiable with specific equipment, but rather represent the end result in terms of performance characteristics which may be obtained. These characteristics may be obtained by using various combinations of equipment. Although the equipment necessary to perform a specified function may be installed at various locations along the path of the service, they will be charged for as a single rate element.

Examples of Optional Features and Functions that are available include, but are not limited to, the following:

- Hubbing Functions
- Bridging
- Multiplexing
- Conditioning
- Secondary Channel

A hub is a Company designated serving wire center at which bridging functions are performed. The bridging functions performed are to connect three or more customer-designated premises in a multipoint arrangement. National Exchange Carrier Association Tariff F.C.C. No. 4 identifies serving wire centers, hub locations and the type of bridging.

Standard offerings are available within each category of service. If a standard offering does not meet a particular customer requirement, the customer may request and the Company may develop a custom offering. The Channel Performance and/or Optional Features and Functions for customer services will be developed and rated on an individual case basis.

5. SERVICES

5.1 GENERAL (Cont'd)

5.1.3 SERVICE CONFIGURATIONS

The two types of service configurations over which Private Line Transport can be provided are:

- Two-point
- Multipoint

A. Two-Point Service

A two-point service connects two customer-designated premises through company wire centers or a customer designated premises and a wire center.

Applicable rate categories are:

- Network Access Channel
- Transport Mileage (when applicable)
- Channel Performance
- Optional Features and Functions (when applicable)

The following diagram depicts a two-point service connecting two customer-designated premises with serving wire centers (SWC) located 15 miles apart. This service is provided with C1 - Type Conditioning. The location of the Network Channel Interface (NCI) is noted on the diagram.

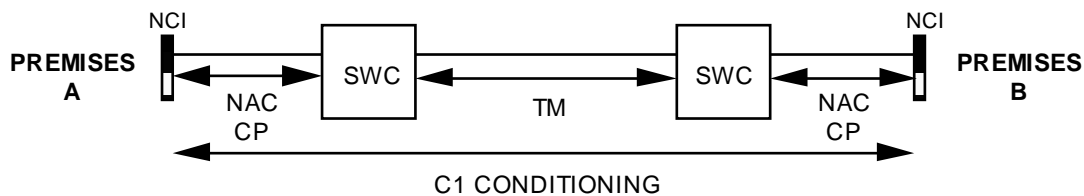

Applicable rate categories for this example are:

- Network Access Channels (NAC) (2)
- Transport Mileage (TM) (Mileage band over 8 to 25 miles)
- Channel Performance (CP) (2)
- Optional Features and Functions (C1 Conditioning) (2)

Qwest Corporation
Private Line Transport Services
Catalog

State of North Dakota
Effective: 3-9-2001

SECTION 5
Page 7
Release 1

5. SERVICES

5.1 GENERAL

5.1.3 SERVICE CONFIGURATIONS (Cont'd)

B. Multipoint Service

Multipoint service connects three or more customer designated premises through a Company wire center. When more than four bridging locations are provided in tandem, the quality of the service may be degraded. Only certain types of Private Line Transport are provided as multipoint service. These are so designated in the Service Descriptions set forth in 5.2, following.

When ordering, the customer may specify the desired bridging location(s) selected from the National Exchange Carrier Association Tariff F.C.C. No. 4. The Company, when requested to do so, will assist the customer in selecting the bridge location(s).

Applicable rate categories are:

- Network Access Channel
- Transport Mileage (when applicable)
- Channel Performance
- Optional Features and Functions (when applicable)

5. SERVICES

5.1 GENERAL

5.1.3 SERVICE CONFIGURATIONS

B. Multipoint Service (Cont'd)

1. Multipoint Analog Service

The following diagram depicts a service connecting four customer-designated premises, each served by a different SWC. The location of the Network Channel Interface (NCI) is noted on the diagram.

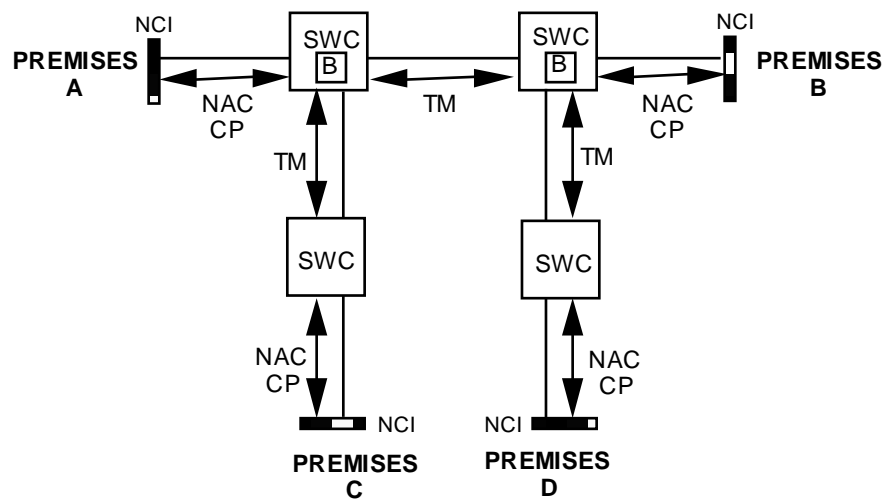

- Network Access Channel (NAC) (4)
- Transport Mileage (TM) (3 sections, each from the appropriate mileage band)
- Channel Performance (CP) (4)
- Optional Features and Functions - bridging (B) (6 applicable, one per port)

5. SERVICES

5.1 GENERAL

5.1.3 SERVICE CONFIGURATIONS

B. Multipoint Service (Cont'd)

2. Multipoint Digital Data Service

The following diagram depicts a Digital Data service connecting four customer-designated premises, each served by a different SWC. The location of the Network Channel Interface (NCI) is noted on the diagram.

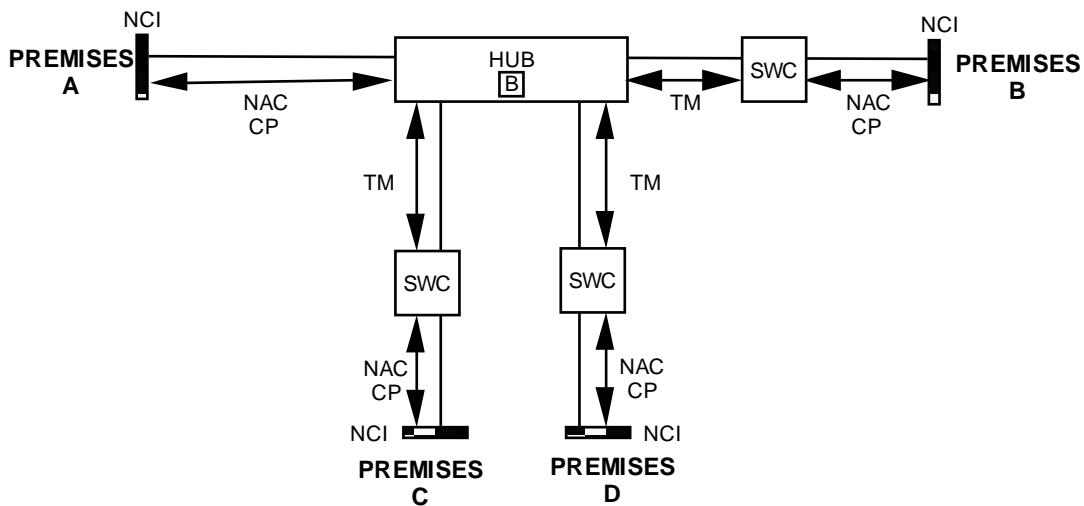

- Network Access Channel (NAC) (4)
- Transport Mileage (TM) (3 sections, each from the appropriate mileage band)
- Channel Performance (CP) (4)
- Optional Features and Functions - bridging (B) (4 applicable, one per port)

Qwest Corporation
Private Line Transport Services
Catalog

State of North Dakota
Effective: 3-9-2001

SECTION 5
Page 10
Release 1

5. SERVICES

5.1 GENERAL (Cont'd)

5.1.4 FACILITY HUBS

A customer has the option of ordering digital facilities (e.g., DS1) to a facility hub for channelizing to individual services requiring lower capacity facilities (e.g., Voice Grade, Audio, etc.) where facilities are available.

Different locations may be designed as hubs for different facility capacities, e.g., multiplexing from digital to digital may occur at one location while multiplexing from digital to analog may occur at a different location. When ordering, the customer will specify the desired multiplexing hub(s) selected from the National Exchange Carrier Association Tariff F.C.C. No. 4. This Catalog identifies the type(s) of multiplexing functions which are available and the serving wire centers at which they are available.

Some of the types of multiplexing available include the following:

- from higher to lower bit rate
- from digital to voice frequency channels

End-to-end services may be provided on channels of these facilities to a hub. The transmission performance for the end-to-end service provided between the customer designated premises will be that of the lower capacity or bit rate. For example, when a 1.544 Mbit/s facility is multiplexed to voice frequency channels, the transmission performance of the channelized services will be voice grade, not DS1.

The Company will commence billing the monthly rate for the facility to the hub on the service due date specified by the customer on the service order. Individual services utilizing these facilities may be installed coincident with the installation of the facility to the hub, or may be ordered and/or installed at a later date, at the option of the customer. The customer will be billed for the appropriate Network Access Channel, Channel Performance, Transport Mileage (when applicable), and the multiplexer at the time the facility is installed. Individual service rates (by service type) will apply for a Network Access Channel, Channel Performance and additional Transport Mileage (as required) for each channelized service. These will be billed to the customer as each individual service is installed.

Qwest Corporation
Private Line Transport Services
Catalog

State of North Dakota
Effective: 3-9-2001

SECTION 5
Page 11
Release 1

5. SERVICES

5.1 GENERAL

5.1.4 FACILITY HUBS (Cont'd)

Cascading multiplexing occurs when a digital channel is de-multiplexed to provide channels with a lesser capacity and one of the lesser capacity channels is further de-multiplexed. For example, a DS1 facility is de-multiplexed to twenty-three DS0 facilities and then one of the DS0 facilities is further de-multiplexed to subrate (e.g., ten 4.8 kbit/s).

When cascading multiplexing is performed whether in the same or a different hub, a charge for the additional multiplexing unit also applies. When cascading multiplexing is performed at different hubbing locations, Transport Mileage charges also apply between the hubs.

5.1.5 SHARED USE

Shared Use occurs when Private Line Transport Service and Switched Access Service are provided over the same DS1 facilities through a common interface. The facility will be ordered, provided and rated as Private Line Transport Service. The nonrecurring charge that applies when the Shared Use Facility is installed will be the nonrecurring charge associated with the appropriate Private Line Transport DS1 Channel. Rating as Private Line Transport will continue until such time as the customer chooses to use a portion of the available capacity for providing Switched Access Service. As each individual channel is activated for Switched Access Service, the Private Line Transport rates will be reduced accordingly (e.g., 1/24th for a DS1 service, etc.). The customer must place an order for each individual Switched Access or Private Line Transport Service utilizing the Shared Use Facilities and specify the channel assignment for each such service.

Switched Access Service rates and charges will apply for each channel of the Shared Use Facility that is used to provide Switched Access Service. Where Private Line Transport Service is provided utilizing a channel of the Shared Use Facility to the hub, DS1 rates and charges will apply for the facility to the hub and individual service rates and charges will apply from the hub to the customer designated premises. The rates and charges that will apply to the portion from the hub to the customer designated premises will be dependent on the specific type of Private Line Transport Service that is provided (e.g., Voice Grade, etc.).

Qwest Corporation d/b/a CenturyLink QC
Private Line Transport Services
Catalog

State of North Dakota
Effective: 12-01-2020

SECTION 5
Page 12
Release 2

5. SERVICES

5.2 SERVICE DESCRIPTIONS

5.2.1 LOW-SPEED DATA SERVICE [1]

(C)

B. Basic Circuit Description

These unconditioned channels are capable of transmitting low speed varying signals at rates up to 30 baud or binary signals at rates of 0-150 baud. Low-Speed Data Channels are furnished and rated from a POT to a POT or bridging location to a POT. These channels are furnished on a two-point or multipoint basis.

Information pertaining to the technical specifications and compatible channel interfaces is set forth in the Technical Publications listed under the Reference to Technical Publications, preceding.

B. End-Link or Mid-Link Application

This application is intended for customers requiring Private Line Transport as part of an overall circuit, extending beyond the LATA. Several Channel Performances are available to facilitate compatibility and a mechanized Design Layout Report (DLR) is available to the customer to assist in their overall design. The network channel interface between the Company facility and the remainder of the overall circuit is referred to as the Mid User-POT (Point of Termination). The network channel interface that is at the terminating end of the overall circuit is referred to as the End User-POT. Following are the service categories that normally apply to the End-link or Mid-link application.

[1] Effective December 1, 2020 Low Speed Data Services are grandfathered. Availability to current customers is limited to circuits in service at existing locations.

(N)
|
(N)

ND2020-13

Qwest Corporation d/b/a CenturyLink QC
Private Line Transport Services
Catalog

State of North Dakota
Effective: 10-1-2001

SECTION 5
Page 13
Release 2

5. SERVICES

5.2 SERVICE DESCRIPTIONS

5.2.1 LOW-SPEED DATA SERVICE [1]

(C)

B. End-Link or Mid-Link Application (Cont'd)

1. Service Categories

- TG1 – A circuit suitable for the transmission of asynchronous transitions between two current levels at rates up to 75 baud. This service is provided on a two-point or multipoint basis. The transmission interfaces are provided on a two-wire or four-wire basis.

^[1] **Effective December 1, 2020 Low Speed Data Services are grandfathered. Availability to current customers is limited to circuits in service at existing locations.**

(N)
|
(N)

ND2020-13

Qwest Corporation d/b/a CenturyLink QC
Private Line Transport Services
Catalog

State of North Dakota
Effective: 12-01-2020

SECTION 5
Page 14
Release 2

5. SERVICES

5.2 SERVICE DESCRIPTIONS

5.2.1 LOW-SPEED DATA SERVICE [1] (Cont'd)

(C)

C. End-To-End Application

This application is intended for customers requiring an overall Private Line Transport, furnished by the Company within the LATA. No DLR will be provided since the performance and maintenance will be the responsibility of the Company. The network channel interface at the terminating end of the overall circuit is referred to as the End User-POT. Following are the service categories that normally apply to the End-to-End application:

1. Service Categories

- LS31 - Provides for data transfer at speeds within the range of 0 to 150 baud. The channel is further defined by speed into the following functions:

0-30 baud channels provide:

- Two-point service used for key control circuits or remote status monitoring, furnished on a two-wire only basis.[2]
- Two-point or multipoint service intended for use in McCulloh Alarm-type applications, furnished on a two-wire only basis.
- DC Channel (metallic channel) current or voltage interfaces on a two-wire basis. Available at the Company's option, on an intra office basis only where facilities and operations permit. This two-point or multipoint service is intended for applications where dc continuity is required.

(T)

0-75 baud channels are available on a two-point or multipoint basis and are intended for telegraph grade applications.

0-150 baud channels provide EIA RS 232 interfaces. The service is available on a two-point or multipoint basis and is intended for telegraph grade applications.

[1] Effective December 1, 2020 Low Speed Data Services are grandfathered. Availability to current customers is limited to circuits in service at existing locations.

(N)
|
(N)

[2] When used as a control type channel, a CPE key may also be required.

(T)

ND2020-13

Qwest Corporation d/b/a CenturyLink QC
Private Line Transport Services
Catalog

State of North Dakota
Effective: 12-01-2020

SECTION 5
Page 15
Release 3

5. SERVICES

5.2 SERVICE DESCRIPTIONS

5.2.1 LOW-SPEED DATA SERVICE [1] (Cont'd)

(C)

D. End-Link or Mid-Link and End-To-End Application

- Low-Speed Data-Custom

A Custom Low-Speed Data channel may be provided upon request when parameters and/or features are not provided by the standard Low-Speed Data channels.

E. Terms and Conditions

The continued use of metallic facilities may be denied to existing customers in accordance with 2.1.8, preceding.

All Network Access Channels must have the same Channel Performance. Any deviation from the established parameters on a given circuit will be handled on an individual case basis. All transmission measurements will be measured from the primary station.

F. Optional Features and Functions

1. Central Office Bridging Capability

- a. McCulloh Bridging allows the connection of up to 26 customer premises. This bridging is only available with McCulloh Alarm-type service.
- b. Telegraph Bridging allows the connection of three or more customer designated premises.
- c. Direct Bridging connects three or more customer designated premises on the DC Channel.

[1] Effective December 1, 2020 Low Speed Data Services are grandfathered. Availability to current customers is limited to circuits in service at existing locations.

(N)
|
(N)

**Qwest Corporation d/b/a CenturyLink QC
Private Line Transport Services
Catalog**

State of North Dakota
Effective: 12-01-2020

SECTION 5
Page 16
Release 4

5. SERVICES

5.2 SERVICE DESCRIPTIONS

5.2.1 LOW-SPEED DATA SERVICE [1] (Cont'd)

(C)

G. Service Information

	SERVICE	NETWORK CHANNEL CODE
0. End-Link or Mid-Link		
	TG1	NW
	Custom	MQ,NQ
0. End-to-End		
	LS-31 Control Status	UY
	LS-31 McCulloh Alarm Type	UY
	LS-31 DC Channel	UY
	LS-31 Telegraph 0-75 Baud	UY
	LS-31 Telegraph 0-150 Baud	UY
	Custom	UN

[1] Effective December 1, 2020 Low Speed Data Services are grandfathered. Availability to current customers is limited to circuits in service at existing locations.

(N)
|
(N)

ND2020-13

NOTICE
THE INFORMATION CONTAINED IN THIS DOCUMENT IS SUBJECT TO CHANGE.

Qwest Corporation d/b/a CenturyLink QC
Private Line Transport Services
Catalog

State of North Dakota
Effective: 12-01-2020

SECTION 5
Page 17
Release 3

5. SERVICES

5.2 SERVICE DESCRIPTIONS (Cont'd)

5.2.2 VOICE GRADE SERVICE [1]

(C)

A. Basic Description

Voice Grade circuits are provided with a bandwidth of 300-3000 Hz designed to meet certain specifications based on Company standards of measurement for voice transmission, data transmission, remote metering, telephoto and miscellaneous signaling purposes. Such identification is not intended to limit a customer's use of the circuits nor to imply that the circuit is limited to a particular use. These circuits are not suitable for the transmission of direct current pulses. The number of stations that may be connected and the distance over which transmission is possible may be limited by operating and transmission factors. Circuits are furnished as either two-wire or four-wire on a two-point or multipoint basis.

Information pertaining to the technical specifications and compatible channel interfaces is set forth in the Technical Publications listed under the Reference to Technical Publications, preceding.

B. End-Link or Mid-Link Application

This application is intended for customers requiring Private Line Transport as part of an overall circuit, extending beyond the LATA. Several Channel Performances are available to facilitate compatibility and a mechanized Design Layout Report (DLR) is available to the customer to assist in their overall design. The network channel interface between the Company facility and the remainder of the overall circuit is referred to as the Mid User-POT (Point of Termination). The network channel interface that is at the terminating end of the overall circuit is referred to as the End User-POT. Following are the service categories that normally apply to the End-link or Mid-link application.

1. Service Categories

- VG2 - Suitable for use as a voice two-point or multipoint private line and switched special service circuit. The transmission interfaces are either two-wire or four-wire.

[1] Effective December 1, 2020 Voice Grade Data Services are grandfathered. Availability to current customers is limited to circuits in service at existing locations.

(N)
|
(N)

ND2020-13

NOTICE
THE INFORMATION CONTAINED IN THIS DOCUMENT IS SUBJECT TO CHANGE.

Qwest Corporation d/b/a CenturyLink QC
Private Line Transport Services
Catalog

State of North Dakota
Effective: 12-1-2020

SECTION 5
Page 18
Release 3

5. SERVICES

5.2 SERVICE DESCRIPTIONS

5.2.2 VOICE GRADE SERVICE [1]

(C)

B.1. (Cont'd)

- VG6 - Suitable for voice grade analog data circuits (Applications may be limited). This service is provided on a two-point or multipoint basis. The transmission interfaces are provided on a four-wire basis only.
- VG7 - Suitable for two-point use for a switched or nonswitched data circuit. The transmission interfaces may be either two-wire or four-wire.
- VG12 - Suitable for specialized voice grade private line audio tone protective relaying circuit. High Voltage Power protection is required for provision of VG12 service. This service is provided on a two-point or multipoint basis. The transmission interfaces are provided as either two-wire or four-wire.

[1] Effective December 1, 2020 Voice Grade Data Services are grandfathered. Availability to current customers is limited to circuits in service at existing locations.

(N)
|
(N)

ND2020-13

Qwest Corporation d/b/a CenturyLink QC
Private Line Transport Services
Catalog

State of North Dakota
Effective: 12-1-2020

SECTION 5
Page 19
Release 4

5. SERVICES

5.2 SERVICE DESCRIPTIONS

5.2.2 VOICE GRADE SERVICE [1] (Cont'd)

(C)

1. End-To-End Application

This application is intended for customers requiring an overall Private Line Transport, furnished by the Company within the LATA. No DLR will be provided since the performance and maintenance will be the responsibility of the Company. The network channel interface at the terminating end of the overall circuit is referred to as the End User – POT. Following are the service categories that normally apply to the End-to-End application:

2. Service Categories

- VG32 – is suitable for use as a two-point or multipoint line-type circuit. The basic channel is modified with Channel Performance providing no signaling, loop-start or automatic signaling. Data capability may be added to specific combinations of loop-start signaling circuits. The loop-start signaling option provides the additional capabilities of extending the signaling ranges and of offering repeated ringing for PBX station ports.
- VG33 – is suitable for use as a two-point trunk-type circuit. The basic channel is modified with Channel Performance providing no signaling, E&M or ground-start signaling. Data capability may be added to specific combinations of E&M or ground-start signaling circuits.
- VG36 – is suitable for use as a two-point or multipoint voice grade (analog) circuit. All channels are provided with basic data transmission parameters modified by the appropriate Channel Performance. Additional conditioning parameters may be added to the basic Channel Performance. These conditioning parameters allow the section of attenuation distortion/envelope delay and intermodulation distortion as needed.

[1] Effective December 1, 2020 Voice Grade Data Services are grandfathered. Availability to current customers is limited to circuits in service at existing locations.

(N)
|
(N)

ND2020-13

NOTICE
THE INFORMATION CONTAINED IN THIS DOCUMENT IS SUBJECT TO CHANGE.

Qwest Corporation d/b/a CenturyLink QC
Private Line Transport Services
Catalog

State of North Dakota
Effective: 12-1-2020

SECTION 5
Page 20
Release 3[1]

5. SERVICES

5.2 SERVICE DESCRIPTIONS

5.2.2 VOICE GRADE SERVICE [2] (Cont'd)

(C)

D. End-Link or Mid-Link and End-To-End Application

1. Voice Grade Custom (VGC)

VGC service is a voice grade service that may be "customized" by specifying any of the technical specifications for VG2, VG6, VG7, VG12 or VG32 through 36. The specifications and interfaces chosen must be compatible, technically feasible, and available.

VGC would be recommended when (1) a VG type does not meet a customer's criteria, (2) parameters from more than one VG type meet the customer's requirements, (3) or the Company can provide according to the customer's specifications and the specifications are provided for in accordance with this Catalog.

E. Optional Features and Functions

1. Central Office Bridging Capability

Provides the capability to connect three or more customer-designated premises. Various types of central office bridging are available as defined in the following:

a. Resistive Bridging

For use on two-wire and four-wire Voice Grade services connected for voice or data communications.

b. Bridge Lifter

A two-wire bridge capability that allows the connection of two stations to a single PBX or Centrex-type line.

[1] This page cancels Page 21, Release 1.

[2] **Effective December 1, 2020 Voice Grade Data Services are grandfathered. Availability to current customers is limited to circuits in service at existing locations.**

(N)
|
(N)

Qwest Corporation d/b/a CenturyLink QC
Private Line Transport Services
Catalog

State of North Dakota
Effective: 10-1-2001

SECTION 5
Page 22
Release 2

5. SERVICES

5.2 SERVICE DESCRIPTIONS

5.2.2 VOICE GRADE SERVICE [1]

(C)

E. Optional Features and Functions (Cont'd)

2. Conditioning

Conditioning provides enhanced transmission characteristics to each applicable Voice Grade service. These options allow the customer to specify attenuation distortion, envelope delay distortion, intermodulation distortion, or signal to C-notched noise. The conditioning option applies to each Network Access Channel. Refer to the Optional Features and Functions Table in 11., following, and the Reference to Technical Publication preceding.

[1] Effective December 1, 2020 Voice Grade Data Services are grandfathered. Availability to current customers is limited to circuits in service at existing locations.

(N)
|
(N)

ND2020-13

NOTICE
THE INFORMATION CONTAINED IN THIS DOCUMENT IS SUBJECT TO CHANGE.

Qwest Corporation d/b/a CenturyLink QC
Private Line Transport Services
Catalog

State of North Dakota
Effective: 12-1-2020

SECTION 5
Page 23
Release 3

5. SERVICES

5.2 SERVICE DESCRIPTIONS

5.2.2 VOICE GRADE SERVICE [1]

(C)

E. Optional Features and Functions (Cont'd)

3. Data Channel Terminating Equipment

Data Channel Terminating Equipment (DCTE) is available for use on certain four-wire voice grade services. A customer powered DCTE unit is a standard provision whenever the customer specifies the DA interface code. The following option is available:

- This option provides data equalization with central office powered 2713 Hz tone activated loop back relay. This option assists in providing service continuity during commercial ac power outages.

4. Customer Specified Levels

The customer may specify transmit and/or receive levels within ranges as delineated in the appropriate technical reference. This option applies to customer specified level(s) other than the recommended level(s) shown in the technical references.

[1] Effective December 1, 2020 Voice Grade Data Services are grandfathered. Availability to current customers is limited to circuits in service at existing locations.

(N)
|
(N)

ND2020-13

NOTICE
THE INFORMATION CONTAINED IN THIS DOCUMENT IS SUBJECT TO CHANGE.

**Qwest Corporation d/b/a CenturyLink QC
Private Line Transport Services
Catalog**

State of North Dakota
Effective: 12-1-2020

SECTION 5
Page 24
Release 3

5. SERVICES

5.2 SERVICE DESCRIPTIONS

5.2.2 VOICE GRADE SERVICE [1]

E. Optional Features and Functions (Cont'd)

(C)

11. Optional Features and Functions Table

The following table shows the technical specifications packages with which the Optional Features and Functions are available.

	<u>END-LINK OR MID-LINK</u>					<u>END-TO-END</u>			
	C	2	6	7	12	C	32	33	36
CO Bridging									
Resistive	x	x	x		x	x	x		x
Bridge Lifter	x	x				x	x		
Conditioning									
C1 Cond.						x			x
C2 Cond.						x			x
C4 Cond.						x			x
D Cond.						x			x
Data Channel									
Terminating Equip.	x		x			x			x
Customer Specified									
Levels	x	x	x	x	x	x	x	x	x

[1] Effective December 1, 2020 Voice Grade Data Services are grandfathered. Availability to current customers is limited to circuits in service at existing locations.

(N)
|
(N)

**Qwest Corporation d/b/a CenturyLink QC
Private Line Transport Services
Catalog**

State of North Dakota
Effective: 12-01-2020

SECTION 5
Page 25
Release 4

1. SERVICES

5.2 SERVICE DESCRIPTIONS

5.2.2 VOICE GRADE SERVICE [1] (Cont'd)

(C)

F. Service Information

	SERVICE	NETWORK CHANNEL CODE
2. End-Link or Mid-Link		
	VG2	LC
	VG6	LG
	VG7	LH
	VG12	LR
	Custom	LQ
3. End-to-End		
	VG32	UC
	VG33	UD
	VG36	UG
	Custom	UQ

[1] Effective December 1, 2020 Voice Grade Data Services are grandfathered. Availability to current customers is limited to circuits in service at existing locations.

(N)
|
(N)

ND2020-13

NOTICE
THE INFORMATION CONTAINED IN THIS DOCUMENT IS SUBJECT TO CHANGE.

Qwest Corporation d/b/a CenturyLink QC
Private Line Transport Services
Catalog

State of North Dakota
Effective: 10-1-2001

SECTION 5
Page 26
Release 2

5. SERVICES

5.2 SERVICE DESCRIPTIONS (Cont'd)

5.2.4 AUDIO SERVICE [1]

(C)

A. Basic Description

Audio channels are provided for the transmission of non-broadcast program signals on a two-point or multipoint basis. The channels are furnished on a monthly basis for closed circuit (non-broadcast) transmission of voice and/or music signals in one direction only.

Audio channels are provided between customer designated premises or between customer designated premises and a Company wire center. The service arrangement is limited to the Audio service category and may not be combined with other Private Line Transport classes of service. The basic rate structure consists of the Network Access Channel, Channel Performance appropriate to the transmission level required and, if applicable, Transport Mileage from the appropriate mileage band. Service for broadcast audio purposes may be found in F.C.C. Tariff No. 1.

Information pertaining to the technical specifications and compatible channel interfaces is set forth in the Technical Publications listed under the Reference to Technical Publications preceding.

B. End-Link or Mid-Link Application

This application is intended for customers requiring Private Line Transport as part of an overall circuit, extending beyond the LATA. Several Channel Performances are available to facilitate compatibility and a mechanized Design Layout Report (DLR) is available to the customer to assist in their overall design. The network channel interface between the Company facility and the remainder of the overall circuit is referred to as the Mid User-POT (Point of Termination). The network channel interface that is at the terminating end of the overall circuit is referred to as the End User-POT. The following service category normally applies to the End-link or Mid-link application.

[1] Effective December 1, 2020 Audio Data Services are grandfathered. Availability to current customers is limited to circuits in service at existing locations.

(N)
|
(N)

ND2020-13

NOTICE
THE INFORMATION CONTAINED IN THIS DOCUMENT IS SUBJECT TO CHANGE.

Qwest Corporation d/b/a CenturyLink QC
Private Line Transport Services
Catalog

State of North Dakota
Effective: 12-1-2020

SECTION 5
Page 27
Release 3

5. SERVICES

5.2 SERVICE DESCRIPTIONS

5.2.4 AUDIO SERVICE [1]

(C)

B. End-Link or Mid-Link Application (Cont'd)

1. Service Categories

- AP4 - provides a channel with a nominal bandpass from 50 to 15000 Hz.

C. End-To-End Application

This application is intended for customers requiring an overall Private Line Transport, furnished by the Company within the LATA. No DLR will be provided since the performance and maintenance will be the responsibility of the Company. The network channel interface at the terminating end of the overall circuit is referred to as the End User-POT. Following are the service categories that normally apply to the End-to-End application:

1. Service Categories

- AP31 - provides a non-equalized channel with a nominal bandpass from 200 to 3000 Hz.
- AP32 - provides an equalized channel with a nominal bandpass from 100 to 5000 Hz.
- AP33 - provides an equalized channel with a nominal bandpass from 50 to 8000 Hz.
- AP34 - provides an equalized channel with a nominal bandpass from 50 to 15000 Hz.

[1] Effective December 1, 2020 Audio Data Services are grandfathered. Availability to current customers is limited to circuits in service at existing locations.

(N)
|
(N)

ND2020-13

NOTICE
THE INFORMATION CONTAINED IN THIS DOCUMENT IS SUBJECT TO CHANGE.

**Qwest Corporation d/b/a CenturyLink QC
Private Line Transport Services
Catalog**

State of North Dakota
Effective: 12-01-2020

SECTION 5
Page 28
Release 4

5. SERVICES

5.2 SERVICE DESCRIPTIONS

5.2.4 AUDIO SERVICE [1] (Cont'd)

(C)

D. End-Link or Mid-Link and End-To-End Application

- AP Custom - a Custom Audio service may be requested to meet specific customer needs not available with the AP standard Channel Performances.

E. Optional Features and Functions

1. Central Office Bridging Capability

Central Office Bridging (distribution amplifier) is offered for connection of multiple customer designated premises of three or more.

F. Service Information

SERVICE	NETWORK CHANNEL CODE
1. End-Link or Mid-Link	
AP4-15.0 kHz	PK
Custom	PQ
2. End-to-End	
AP31-3.0 kHz	UE
AP32-5.0 kHz	UE
AP33-8.0 kHz	UE
AP34-15.0 kHz	UE
Custom	UP

[1] Effective December 1, 2020 Audio Data Services are grandfathered. Availability to current customers is limited to circuits in service at existing locations.

(N)
|
(N)

ND2020-13

Qwest Corporation
Private Line Transport Services
Catalog

State of North Dakota
Effective: 12-15-2004

SECTION 5
Page 29
Release 2

5. SERVICES

5.2 SERVICE DESCRIPTIONS (Cont'd)

5.2.5 FOREIGN EXCHANGE SERVICE

A. Basic Description

Foreign Exchange (FX) Service provides dial tone from a wire center in an exchange from which the customer is not normally served, or where the customer is located outside an exchange in unassigned territory. This service is available to either residence or business customers but will not be provided for resale.

B. Terms and Conditions

1. Where facility conditions permit, the Company will provide FX Service at the rates shown herein. Where FX Service is furnished at remote or isolated locations, or where facilities are not available, or where unusual costs are involved, additional nonrecurring, construction, and/or monthly charges may apply.
2. FX Service is normally furnished to a single customer premises. Where facility conditions permit, up to two additional points may be added.
3. When a customer subscribes to local services and requests an extension in a foreign exchange, a Network Access Channel, Channel Performance and Transport Mileage, as specified for Foreign Exchange Service, will apply to the extension.
4. Foreign Exchange Service is not furnished in connection with Smart Public Access Line Service. (C)
5. Directory Listings
 - a. One directory listing will be provided for FX Service in the exchange where the customer's dial tone is obtained.
 - b. Additional listings will be furnished at regular rates and charges as specified in the Exchange and Network Services Price Schedule.
 - c. Listings in other directories will be furnished at the regular rates for foreign listings as specified in the Exchange and Network Services Price Schedule.

Qwest Corporation
Private Line Transport Services
Catalog

State of North Dakota
Effective: 3-9-2001

SECTION 5
Page 30
Release 1

5. SERVICES

5.2 SERVICE DESCRIPTIONS

5.2.5 FOREIGN EXCHANGE SERVICE

B. Terms and Conditions (Cont'd)

6. FX will not be provided on the same circuit as Foreign Central Office (FCO) Service.
7. Message toll rates are applicable in connection with FX Service when calls are placed to telephone numbers outside the local calling area of the dial tone wire center.
8. Rates and terms and conditions associated with Directory Assistance apply and are set forth in the Exchange and Network Services Price Schedule.
9. Use of service limitations as delineated in the Exchange and Network Services Price Schedule apply to FX Service.
10. Foreign Exchange provides unlimited access to and from the local calling area of the foreign wire center.
11. Rates and charges for all Optional Features and Functions are as specified in the Exchange and Network Services Price Schedule.
12. FX Service will obtain a line or trunk from the Exchange and Network Services Price Schedule. The Network Access Channel is also applicable.
13. The rates and charges for individual line service and PBX trunks are those in effect in the serving (foreign) exchange.

Qwest Corporation
Private Line Transport Services
Catalog

State of North Dakota
Effective: 04-19-2017

SECTION 5
Page 31
Release 2

5. SERVICES

5.2 SERVICE DESCRIPTIONS

5.2.5 FOREIGN EXCHANGE SERVICE

B. Terms and Conditions (Cont'd)

14. Locality, suburban, exchange zone rate area increments (ZNA/) or extra exchange line mileage for any main station or PBX located outside the base rate area of the normal exchange do not apply to Foreign Exchange Service.
15. In the case of Centrex main stations, the basic secondary location Centrex station rate schedule will apply at each FX station location in addition to mileage and/or incremental charges.
16. Transport Mileage will be measured and rated from the customer's serving wire center to the remote wire center.
17. Rate Categories
 - Exchange Service Element
 - Network Access Channel (NAC)
 - Channel Performance (CP)
 - Transport Mileage (TM)

C. Service Information

SERVICE	NETWORK CHANNEL CODE	(T)
Foreign Exchange Line	UC	(T)
Foreign Exchange Trunk	UD	(T)

Qwest Corporation
Private Line Transport Services
Catalog

State of North Dakota
Effective: 3-9-2001

SECTION 5
Page 32
Release 1

5. SERVICES

5.2 SERVICE DESCRIPTIONS (Cont'd)

5.2.6 FOREIGN CENTRAL OFFICE SERVICE

A. Basic Description

Foreign Central Office (FCO) Service provides dial tone from a customer's serving wire center to a remote wire center in the same exchange. This service is available to either residence or business customers but will not be provided for resale.

B. Terms and Conditions

1. FCO Service is offered on individual lines and PBX trunks.
2. FCO Service will obtain a line or trunk from the Exchange and Network Services Price Schedule. The Network Access Channel is also applicable.
3. FCO Service is not in accord with the normal plan of furnishing telephone service and the Company does not obligate itself to furnish such service, particularly where it involves undue expense or impairment of the service furnished to the general public.
4. Transport Mileage applies based on airline measurements from the wire center from which the customer actually is served to the serving wire center from which the customer would normally be served.
5. FCO will not be provided on the same circuit as Foreign Exchange (FX) Service.
6. Rates and charges for all Optional Features and Functions are as specified in the Exchange and Network Services Price Schedule.
7. Locality, suburban or exchange zone rate area increments (ZNA/) for any main station or PBX located outside the base rate area of the normal exchange do not apply to Foreign Central Office Service.

Qwest Corporation
Private Line Transport Services
Catalog

State of North Dakota
Effective: 04-19-2017

SECTION 5
Page 33
Release 2

5. SERVICES

5.2 SERVICE DESCRIPTIONS

5.2.6 FOREIGN CENTRAL OFFICE SERVICE

B. Terms and Conditions (Cont'd)

8. Directory Listings

- a. One directory listing will be provided for FCO Service in the wire center where the customer's dial tone is obtained.
- b. Additional listings will be furnished at regular rates and charges as specified in the Exchange and Network Services Price Schedule.
- c. Listings in other directories will be furnished at the regular rates for foreign listings as specified in the Exchange and Network Services Price Schedule.

9. Message toll rates are applicable in connection with FCO Service when calls are placed to telephone numbers outside the local calling area of the dial tone wire center.

10. Rates and terms and conditions associated with Directory Assistance apply and are set forth in the Exchange and Network Services Price Schedule.

11. Use of service limitations as delineated in the Exchange and Network Services Price Schedule apply to FCO Service.

12. The rates for individual line service and PBX trunks are those in effect in the serving (foreign) central office.

13. In the case of Centrex main stations, the basic secondary location Centrex station rate schedule will apply at each FCO station location in addition to mileage and/or incremental charges.

14. Rate Categories

- Exchange Service Element
- Network Access Channel (NAC)
- Channel Performance (CP)
- Transport Mileage (TM)

C. Service Information

SERVICE	NETWORK CHANNEL CODE	(T)
Foreign Central Office Line	UC	(T)
Foreign Central Office Trunk	UD	(T)

NOTICE
THE INFORMATION CONTAINED IN THIS DOCUMENT IS SUBJECT TO CHANGE.

Qwest Corporation
Private Line Transport Services
Catalog

State of North Dakota
Effective: 04-19-2017

SECTION 5
Page 34
Release 2

5. SERVICES

5.2 SERVICE DESCRIPTIONS (Cont'd)

5.2.7 EXCHANGE SERVICE EXTENSIONS (NON-PBX)[1]

A. Basic Description

Channels which extend dial tone from a customer's serving wire center to a noncontinuous property station location. This service is available to either residence or business customers but will not be provided for resale.

B. Terms and Conditions

1. Exchange Service Extension charges are in addition to other rates and charges applicable to the particular service involved.
2. Extension service is provided only to individual lines which terminate at a different premises.
3. When a customer subscribes to local services and requests an extension in a foreign exchange, a Network Access Channel, Channel Performance and Transport Mileage, as specified for Foreign Exchange Service, will apply to the extension.
4. Rate Categories
 - Network Access Channel (NAC)
 - Channel Performance (CP)
 - Transport Mileage (TM)

C. Service Information

SERVICE	NETWORK CHANNEL CODE	(T)
Off Premises Extension Line	UC[2]	(T)

[1] PBX off premises stations are provided via a Voice Grade 32 type circuit.

[2] Interoffice only.

Qwest Corporation
Private Line Transport Services
Catalog

State of North Dakota
Effective: 12-15-2004

SECTION 5
Page 35
Release 3

5. SERVICES

5.2 SERVICE DESCRIPTIONS (Cont'd)

5.2.8 TELEPHONE ANSWERING SERVICE

A. Basic Description

1. A Telephone Answering Service circuit provides access to any individual or firm offering a telephone answering service (TAS) to a number of customers as a general undertaking. This service will not be provided for resale.
2. An individual or firm will be considered as a Telephone Answering Service Bureau for the application of terms, conditions and rates and charges, if any of the following criteria is met:
 - a. Answers a number of telephone lines for other firms or individual patrons or answers calls referred through directory listings for a number of patrons.
 - b. Furnishes an answering service to one or more patrons located outside of the same building in which the answering equipment is located.
 - c. Offers telephone answering service to the general public by advertising in any telephone directory or other publication.
 - d. Requires one or more administrative telephone lines and associated directory listings, indicating telephone answering service is provided.
 - e. Contracts to answer the telephone lines of patrons or take calls through directory listings on a 24-hour basis.

B. Terms and Conditions

1. The continued use of metallic facilities may be denied to existing customers in accordance with 2.1.8, preceding.
2. The TAS bureau is required to contract for the telephone answering service described herein, and in addition is required to subscribe for regular business exchange service, either flat or message rate but not a combination of both. The service of the TAS patron must be individual line, or PBX service.

(C)

Qwest Corporation
Private Line Transport Services
Catalog

State of North Dakota
Effective: 3-9-2001

SECTION 5
Page 36
Release 1

5. SERVICES

5.2 SERVICE DESCRIPTIONS

5.2.8 TELEPHONE ANSWERING SERVICE

B. Terms and Conditions (Cont'd)

3. Lines for connecting the telephone service of the TAS patrons with the answering equipment of the TAS bureau, are known as telephone answering service lines, which are furnished for answering incoming calls only. Such lines may not be used by the TAS bureau for making outgoing calls or for communication between the TAS bureau and its patrons.
4. TAS patrons may have business individual telephone service terminated directly in a TAS bureau where facilities permit. These services so terminated are limited to incoming use only. Regular business individual line flat or message rates as specified in the Exchange and Network Services Price Schedule will apply.
5. TAS patrons may have business individual line service terminated in a jack on the TAS bureau premises. The primary function of such a line is for receiving messages for a patron who is absent from the Telephone Answering Service location for the greater part of the patron's business day.
6. All rates and charges quoted herein for Telephone Answering Service assume that the Company will not be required to provide unusually large amounts of cable facilities required for this type of service at a location remote from its serving wire center or in areas in the exchange where the cable required to provide telephone answering service would not have a normal usage for other services if the telephone answering service were discontinued at such a location. For the purpose of administering this condition, no extra charge will be applicable if the TAS bureau is located within one airline mile of the serving wire center. If the TAS bureau is located more than one airline mile from the serving wire center, special charges will be applicable depending upon the circumstances in each case.
7. When a TAS bureau moves to a different premises within the same exchange, the TAS bureau will be assessed the charges applicable to the reestablishment of all services moved to the new location. These charges include all charges applicable to the telephone answering service lines and business patron service lines reterminated in the TAS bureau answering equipment.
8. When the TAS patron is served out of the same serving wire center as the TAS bureau, the TAS patron is responsible for rates and charges associated with Network Access Channel and Channel Performance.

**Qwest Corporation
Private Line Transport Services
Catalog**

State of North Dakota
Effective: 04-19-2017

SECTION 5
Page 37
Release 3

5. SERVICES

5.2 SERVICE DESCRIPTIONS

5.2.8 TELEPHONE ANSWERING SERVICE

B. Terms and Conditions (Cont'd)

9. When the TAS patron is served from a serving wire center different than the serving wire center of the TAS bureau, the TAS patron is responsible for rates and charges associated with Transport Mileage in addition to the rates and charges for Network Access Channel and Channel Performance(s).

10. Telephone Answering Service Providing Secrecy (Half-Tap)

This arrangement denotes telephone answering service patron lines terminating in a Telephone Answering Service switchboard equipped for answering calls on a ringing impulse basis only.

11. Telephone Answering Service with Privacy (Key Arrangement)

This arrangement denotes telephone answering service patron lines terminating in a Telephone Answering Service switchboard that uses facilities and CO relays to insure privacy. To provide privacy the following equipment is needed:

- CO Relay at the serving wire center.
- CPE Key at the patron's premises.
- Low-Speed Data Channel (Control Channel) between the CPE Key and the CO Relay, refer to Section 6, following.

Rates and charges for the CO Relay and the Low-Speed Data Control Channel are billed to the patron.

12. Rate Categories

- Network Access Channel (NAC)
- Channel Performance (CP)
- Transport Mileage (TM)

C. Service Information

SERVICE	NETWORK CHANNEL CODE	(T)
Secretarial Line	UC[1]	(T)

[1] Interoffice only.

Qwest Corporation d/b/a CenturyLink QC
Private Line Transport Services
Catalog

State of North Dakota
Effective: 12-01-2020

SECTION 5
Page 38
Release 2

5. SERVICES

5.2 SERVICE DESCRIPTIONS (Cont'd)

5.2.9 DIGITAL DATA SERVICE [1]

(C)

A. Basic Description

Digital Data Service (DDS) is provided on a two-point or multipoint, 4-wire basis, for 2.4, 4.8, 9.6, 19.2 or 56 kbit/s transmission of synchronous serial data. Digital Data Service is also provided at 64 kbit/s on a two-point only basis. Subrated DS0 Service is also available. The actual bit rate is a function of the channel interface selected by the customer where applicable. The circuit provides a synchronous service, with timing provided by the Company through the Company's facilities, to the customer in the received bit stream. DDS circuits are provided between customer designated premises, between a customer designated premises and a Company Hub or designated digital wire center, or between Company Hubs or designated digital wire centers.

A Subrated DS0 Service (HCO) transports multiple subrate digital data channels, i.e., twenty 2.4, ten 4.8, or five 9.6 kbit/s, between Digital Data Hubs.

When a 64 kbit/s DDS circuit is multiplexed onto a DS1 Service, the DS1 Service must be optioned for Clear Channel Capability.

Information pertaining to the technical specifications for this service is found in 1.9, Reference to Technical Publications.

B. End-Link or Mid-Link Application

This application is intended for customers requiring Private Line Transport as part of an overall circuit, extending beyond the LATA. Several Channel Performances are available to facilitate compatibility and a mechanized Design Layout Report (DLR) is available to the customer to assist in their overall design. The network channel interface between the Company facility and the remainder of the overall circuit is referred to as the Mid User-POT (Point of Termination). The network channel interface that is at the terminating end of the overall circuit is referred to as the End User-POT. Following are the service categories that normally apply to the End-link or Mid-link application.

C. End-To-End Application

This application is intended for customers requiring an overall Private Line Transport, furnished by the Company within the LATA. No DLR will be provided since the performance and maintenance will be the responsibility of the Company. The network channel interface at the terminating end of the overall circuit is referred to as the End User-POT.

[1] Effective December 1, 2020 Digital Data Services are grandfathered. Availability to current customers is limited to circuits in service at existing locations.

(N)
(N)

Qwest Corporation d/b/a CenturyLink QC
Private Line Transport Services
Catalog

State of North Dakota
Effective: 12-01-2020

SECTION 5
Page 39
Release 2

5. SERVICES

5.2 SERVICE DESCRIPTIONS

5.2.9 DIGITAL DATA SERVICE [1] (Cont'd)

(C)

2. Optional Features and Functions

3. Bridging

Bridging is an arrangement within DDS Hub(s) to connect three or more customer designated premises to form multipoint networks. It permits a customer to transmit communications from one location to many locations simultaneously and/or receive communications at a single location from many locations. It is not available with 64 kbit/s or Subrated DS0. All Network Access Channels connected by Bridging must operate at the same transmission speed.

4. Secondary Channel

Secondary Channel provides an independent lower rate channel which allows diagnostic, maintenance and network administration capabilities. This enhancement is available with 4.8, 9.6, 19.2 and 56 kbit/s on two-point and multipoint arrangements. This offering is contingent upon equipment and facility availability.

Secondary Channel Service does not constitute a 64 kbit/s Clear Channel Capacity nor shall the offering of Secondary Channel Service obligate the Company to provision it using any specific 64 kbit/s Clear Channel Capability protocols.

When the control leg of a multipoint 56 kbit/s DDS circuit with Secondary Channel is multiplexed onto a DS1 Service, the DS1 Service must be optioned for Clear Channel Capability.

Customer provided equipment interfacing with Secondary Channel service arrangements must be designed in accordance with technical specifications.

[1] Effective December 1, 2020 Digital Data Services are grandfathered. Availability to current customers is limited to circuits in service at existing locations.

(N)
|
(N)

ND2020-13

NOTICE
THE INFORMATION CONTAINED IN THIS DOCUMENT IS SUBJECT TO CHANGE.

Qwest Corporation d/b/a CenturyLink QC
Private Line Transport Services
Catalog

State of North Dakota
Effective: 12-01-2020

SECTION 5
Page 40
Release 2

5. SERVICES

5.2 SERVICE DESCRIPTIONS

5.2.9 DIGITAL DATA SERVICE [1]

(C)

D. Optional Features and Functions (Cont'd)

3. Central Office DS0 to Subrate (DS0B to DS0A Subrate) Multiplexing

An arrangement that provides a Company multiplexer which converts a Subrated DS0 (DS0B) channel containing up to twenty 2.4 kbit/s, ten 4.8 kbit/s, or five 9.6 kbit/s channels into individual 2.4, 4.8, or 9.6 kbit/s circuits, each utilizing time division multiplexing. Where available, this option may be applied to both the DS1 to Voice/Data channel and DS1 to DS0 channel multiplexing options, as specified under DS1 Service.

The placement of Digital Data Service and/or SVDS onto a DDS Central Office DS0 to Subrate Multiplexer will only be provided in Digital Data Hub(s).

4. Central Office Multiplexer to Multiplexer Connecting Arrangement

a. Subrate to Subrate

An arrangement that allows a customer to connect an individual channel from one DS0 to Subrate Multiplexer to an individual channel of another DS0 to Subrate Multiplexer, at 2.4, 4.8 or 9.6 kbit/s, within the same Digital Data Hub.

In addition, this arrangement allows a customer to connect an individual channel from one DS0 to Subrate Multiplexer, to an individual channel of another DS0 to Subrate Multiplexer located in a different Digital Data Hub, at 2.4, 4.8 or 9.6 kbit/s. Transport Mileage applies between Digital Data Hubs.

[1] Effective December 1, 2020 Digital Data Services are grandfathered. Availability to current customers is limited to circuits in service at existing locations.

(N)
|
(N)

ND2020-13

NOTICE
THE INFORMATION CONTAINED IN THIS DOCUMENT IS SUBJECT TO CHANGE.

Qwest Corporation d/b/a CenturyLink QC
Private Line Transport Services
Catalog

State of North Dakota
Effective: 12-01-2020

SECTION 5
Page 41
Release 3

5. SERVICES

5.2 SERVICE DESCRIPTIONS

5.2.9 DIGITAL DATA SERVICE [1]

(C)

D.4. (Cont'd)

b. DS0 to DS0

An arrangement that allows a customer to connect an individual channel from one DS1 to DS0 Multiplexer to an individual channel of another DS1 to DS0 Multiplexer, within the same Company serving wire center. In addition, this arrangement can be used to allow a customer to connect an individual channel of one DS1 to Voice Multiplexer to another DS1 to Voice Multiplexer, within the same Company serving wire center. DS0 to DS0 can be used for 2.4, 4.8, 9.6, 19.2, 56 and 64 kbit/s and Subrated DS0 Service. DS0 to DS0 with Secondary Channel can be used for 4.8, 9.6, 19.2, and 56 kbit/s.

In addition, this arrangement allows a customer to connect an individual channel from one DS1 to DS0/Voice Multiplexer, to an individual channel of another DS1 to DS0/Voice Multiplexer located in a different Digital Data Hub. Transport Mileage applies between Digital Data Hubs.

- c. When a Central Office Multiplexer to Multiplexer Connecting Arrangement is made within the same Digital Data Hub, only one arrangement will apply. When a Central Office Multiplexer to Multiplexer Connecting Arrangement is made in different Digital Data Hub(s), one arrangement will apply for each Digital Data Hub. Transport Mileage will also apply. For example, a customer wants to connect one 2.4 kbit/s channel on a DS0 to Subrate Multiplexer from Digital Data Hub A to a DS0 to Subrate Multiplexer in Digital Data Hub B. The customer would pay for two Central Office Multiplexer to Multiplexer Connecting Arrangements and Transport Mileage as set forth in Section 6, following.

[1] Effective December 1, 2020 Digital Data Services are grandfathered. Availability to current customers is limited to circuits in service at existing locations.

(N)
|
(N)

Qwest Corporation d/b/a CenturyLink QC
Private Line Transport Services
Catalog

State of North Dakota
 Effective: 12-01-2020

SECTION 5
 Page 42
 Release 3

5. SERVICES

5.2 SERVICE DESCRIPTIONS

5.2.9 DIGITAL DATA SERVICE [1] (Cont'd)

(C)

E. Service Information

64. End-Link or Mid-Link

SERVICE	NETWORK CHANNEL CODE	
2.4 kbit/s	XA	
4.8 kbit/s	XB	
9.6 kbit/s	XG	
19.2 kbit/s	XE	
56 kbit/s	XH	
64 kbit/s	XE	
Subrate DS0	HS	
Custom	[2]	(T)

2. End-to-End

2.4 kbit/s	US
4.8 kbit/s	US
9.6 kbit/s	US
19.2 kbit/s	US
56 kbit/s	US
64 kbit/s	US
Subrate DS0	HS
Custom	UX

[1] Effective December 1, 2020 Digital Data Services are grandfathered. Availability to current customers is limited to circuits in service at existing locations. (N)
 |
 (N)

[2] Use same Network Channel Code as the speed with which the Custom offering is associated. (T)

ND2020-13

Qwest Corporation
Private Line Transport Services
Catalog

State of North Dakota
Effective: 3-9-2001

SECTION 5
Page 43
Release 1

5. SERVICES

5.2 SERVICE DESCRIPTIONS (Cont'd)

5.2.10 DS1 SERVICE

A. Description

DS1 Service provides for the two-way transmission of 1.544 Mbit/s digital signals, on a point-to-point basis only. DS1 Service can be provisioned on copper, fiber, or other suitable facilities, at the discretion of the Company. DS1 Service may be used for the transmission of voice, data, and video signals, or any combination thereof. DS1 Service is provided between two customer-designated premises, between a customer-designated premises and a Company Serving Wire Center, or between Company Serving Wire Centers. When DS1 Service is requested between two Company Serving Wire Centers, Central Office Multiplexers must also be ordered on each end (i.e., each Serving Wire Center) of the DS1 circuit, and a Private Line Transport service must be ordered from each Central Office Multiplexer to the customer premises.

DS1 Service may also be provided without framing. A Free-Framed DS1 signal shall have electrical characteristics identical to the framed 1.544 Mbit/s signals for DS1 Service with B8ZS, except for the lack of an apparent Frame Format. Free-Framing is not compatible with multiplexed DS1 Service. Free-Framed DS1 can only be provided where suitable equipment is available.

Information pertaining to the technical specifications and compatible channel interfaces is set forth in the Technical Publications listed under the Reference to Technical Publications, preceding. All Frame Format and line code combinations found in the Technical Publication are available for DS1 Service provisioned as point-to-point, or as Central Office multiplexed service.

B. Terms and Conditions

The terms and conditions specified in the DS1 Service Agreement, apply, in addition to the conditions set forth here and in Section 2 of this Catalog.

1. Availability

- DS1 Service is available only on a two-point basis, 24 hours per day, 7 days a week.
- DS1 Service can only be provided from wire centers equipped for digital transmission and is subject to the technical limitations of the CO equipment used by the Company.

Qwest Corporation
Private Line Transport Services
Catalog

State of North Dakota
Effective: 3-9-2001

SECTION 5
Page 44
Release 1

5. SERVICES

5.2 SERVICE DESCRIPTIONS

5.2.10 DS1 SERVICE

B.1.(Cont'd)

- Where suitable facilities are unavailable for provision of the service, special construction of the facilities may be necessary and will be charged for as specified in 2.1.5.
- If a customer requests that DS1 service be provided on fiber facilities, special construction charges as specified in 2.1.5 may apply.
- A customer may request that the facilities used to provide DS1 Service be specially routed. The regulations and charges for Facilities Protection - Special Facilities Routing (i.e., Avoidance and Diversity) are as set forth in 3.1.4.

2. Payment Options

DS1 Service is offered on a month-to-month basis, and on one through ten year Fixed Period Rate Plans, as specified in G.5.

3. Route Discounts

Route discounts are available for customers who purchase multiple, identical DS1 circuits between the same two (2) customer designated premises (i.e., circuits must terminate at the same addresses). Route discounts are applicable only on the Channel Termination and Transport Mileage rate elements. The charges, as specified in 3.8.6, include the route discounts.

4. Custom Offering

If the standard service, as described and offered, does not meet a particular customer requirement, the customer may request and the Company may develop a Custom offering. Special Construction Charges as defined in 2.1.5 may apply.

5. Service Guarantee

Service Guarantee - Repair, as specified in 2.4.4.B.4., preceding, and Service Guarantee - Provisioning, as specified in 3.2.2.M., preceding, do not apply for Free-Framed DS1 Service.

Qwest Corporation
Private Line Transport Services
Catalog

State of North Dakota
Effective: 3-9-2001

SECTION 5
Page 45
Release 1

5. SERVICES

5.2 SERVICE DESCRIPTIONS

5.2.10 DS1 SERVICE (Cont'd)

C. End-link or Mid-link Application

This application is intended for customers requiring DS1 as part of an overall circuit extending beyond the Local Access Transport Area (LATA). A Design Layout Report (DLR) is available to the customer to assist in their overall design. The network channel interface between the Company facility and the remainder of the overall circuit is referred to as the Mid User POT (Point of Termination). The network channel interface that is at the terminating end of the overall circuit is referred to as the End User POT.

D. End-to-End Application

This application is intended for customers requiring a DS1 service provided by the Company within the Local Access and Transport Area (LATA). No Design Layout Report (DLR) will be provided since the performance and maintenance will be the responsibility of the Company. The network channel interface at the terminating end of the overall circuit is referred to as the End User POT.

Qwest Corporation
Private Line Transport Services
Catalog

State of North Dakota
Effective: 3-9-2001

SECTION 5
Page 46
Release 1

5. SERVICES

5.2 SERVICE DESCRIPTIONS

5.2.10 DS1 SERVICE (Cont'd)

E. Rate Categories

There are three basic charge categories which apply to DS1 Service:

- Channel Termination
- Transport Mileage
- Optional Features and Functions

1. Channel Termination

The Channel Termination provides for the communications path between the Demarcation Point at the customer-designated premises, and the Serving Wire Center of that premises. One Channel Termination charge applies per DS1 terminated at the Demarcation Point. This charge will apply even if the customer-designated premises and the Serving Wire Center are collocated in the same building.

If a customer provides the channel facility assignment (CFA) for the multiplexer of a higher capacity service, the DS1 Channel Termination charge does not apply between the Serving Wire Center and the customer's designated premises, connected by the higher capacity service.

For example, if an end-user wants to connect to an Interexchange Carrier's (IC) point of presence (POP), and the IC provides CFA, the DS1 Channel Termination connecting the Serving Wire Center to the IC POP is not billed because the IC is already paying for that connection, via the higher capacity service. If the IC does not provide CFA, then the Company must provide the connection from the Serving Wire Center to the IC POP and the DS1 Channel Termination applies.

Qwest Corporation
Private Line Transport Services
Catalog

State of North Dakota
Effective: 3-9-2001

SECTION 5
Page 47
Release 1

5. SERVICES

5.2 SERVICE DESCRIPTIONS

5.2.10 DS1 SERVICE

E. Rate Categories (Cont'd)

2. Transport Mileage

The Transport Mileage provides for the transmission facilities between the Serving Wire Centers associated with two customer-designated locations. Transport Mileage is portrayed in mileage bands. There are two elements that apply for each band i.e., a fixed band and a per mile band. Transport Mileage is measured by airline miles between Serving Wire Centers via the V and H Coordinates Method, as set forth in the National Exchange Carrier Association Tariff F.C.C. No. 4.

3. Optional Features and Functions

Optional features and functions are available where determined by the Company to be technically feasible.

a. Central Office Multiplexing

(1) DS1 to Voice/Data

An arrangement that provides a Company multiplexer, in a Company central office, which converts a 1.544 Mbit/s channel to twenty-four 64 kbit/s channels. The twenty-four channels may be used for the provision of Private Line Transport Voice or Data applications.

- SuperFrame format with AMI line code
- SuperFrame format with B8ZS line code
- Extended SuperFrame format with AMI line code
- Extended SuperFrame format with B8ZS line code
- Extended SuperFrame with the ZBTISI application and AMI line code
- ANSI Extended SuperFrame format with AMI line code
- ANSI Extended SuperFrame format with B8ZS line code

5. SERVICES

5.2 SERVICE DESCRIPTIONS

5.2.10 DS1 SERVICE

E.3.a. (Cont'd)

(2) DS1 to DS0

An arrangement that converts a 1.544 Mbit/s DS1 channel to twenty-four 64 kbit/s DS0 channels utilizing time division multiplexing. The twenty-four channels are used for Digital Data Services. This option is provided with the following network channel interfaces:

- SuperFrame format with AMI line code
- SuperFrame format with B8ZS line code
- Extended SuperFrame format with AMI line code
- Extended SuperFrame format with B8ZS line code
- ANSI Extended SuperFrame with AMI line code
- ANSI Extended SuperFrame with B8ZS line code

Network channel interfaces are further described in Technical Reference PUB 77200.

b. Central Office Multiplexer to Multiplexer Connecting Arrangement

This arrangement allows a customer to connect an individual DS1 channel from one multiplexer to an individual DS1 channel of another multiplexer, within the same Company serving wire center. In addition, this arrangement can be used to connect an individual DS1 channel of one multiplexer to an individual DS1 channel of another multiplexer, located in a different Company serving wire center. This feature may be optioned for the Bipolar with Eight Zero Substitution (B8ZS) line code.

When a Central Office Multiplexer to Multiplexer Connecting Arrangement is made within the same serving wire center, only one arrangement will apply. When a Central Office Multiplexer to Multiplexer Connecting Arrangement is made in different serving wire centers, one arrangement will apply for each serving wire center. Transport Mileage, if applicable, will also apply. For example, a customer who wants to connect one 1.544 Mbit/s channel on a DS3 to DS1 Multiplexer from serving wire center A to a DS3 to DS1 Multiplexer in serving wire center B, would pay for two Central Office Multiplexer to Multiplexer Connecting Arrangements and Transport Mileage as set forth in Section 6, following.

(T)

Qwest Corporation
Private Line Transport Services
Catalog

State of North Dakota
Effective: 3-9-2001

SECTION 5
Page 49
Release 1

5. SERVICES

5.2 SERVICE DESCRIPTIONS

5.2.10 DS1 SERVICE

E.3. (Cont'd)

c. Clear Channel Capability

An arrangement that allows a customer to transport any framed sequence of binary ones and zeroes through a 1.544 Mbit/s channel.

(1) B8ZS Option

This option requires the customer signal at the channel interface to conform to the Bipolar with Eight Zero Substitution (B8ZS) line code algorithm as described in PUB 77375. This option allows B8ZS line code transmission through the network without being transcoded.

d. Central Office Connecting Channel

The Central Office Connecting Channel provides for connections within the same Hub wire center between one customer leased DS1 Channel and a different customer leased DS1 Channel provided by the Company (e.g., two like services installed as two separate services). One Central Office Connecting Channel charge applies per connection made.

Qwest Corporation
Private Line Transport Services
Catalog

State of North Dakota
Effective: 11-30-2007

SECTION 5
Page 50
Release 2

5. SERVICES

5.2 SERVICE DESCRIPTIONS

5.2.10 DS1 SERVICE

E.3. (Cont'd)

e. Automatic Loop Transfer (Automatic Protection Switching)

The Automatic Loop Transfer option provides protection against failure of metallic facilities between a customer designated premises and the Serving Wire Center for the premises. Protection is furnished through the use of a switching arrangement that automatically switches to a spare DS1 when the working DS1 fails. The spare DS1 is not included as a part of this option, and is charged for in addition to this option. This option requires compatible equipment at both the Serving Wire Center and the customer premises. The customer is responsible for providing the equipment at its premises. This feature is not available with channel having the B8ZS line code.

f. Command A Link

This option allows the customer to control the reconfiguration of a Private Line Transport Service (digital or analog) on a near real-time basis, by means of the special provisioning of these services through a digital cross-connect device. Command A Link can accommodate the termination of circuits up the 64 kbit/s[1], 1.544 Mbit/s[2], and 44.736 Mbit/s[3] signal levels. Customer access to the reconfiguration capability is via a Web Based Access arrangement and/or an Attendant Access arrangement. Terms, conditions, rates and charges for Command A Link are specified in 4.4, preceding.

(C)
|
(C)

Command A Link is available only in selected serving wire centers.

[1] Applicable to Voice Grade and Digital Data Service.

[2] Applicable to Voice Grade, Digital Data Service and DS1 Service.

[3] Applicable to DS1 and DS3 Service.

5. SERVICES

5.2 SERVICE DESCRIPTIONS

5.2.10 DS1 SERVICE

E.3. (Cont'd)

g. Self-Healing Alternate Route Protection (SHARP)

SHARP provides added reliability to DS1 Service transported over fiber facilities. This feature provides a separate facility path to avoid any single point of failure for the protection system between the serving wire center and the Company Demarcation Point, located in the same building as the customer-designated premises, when the customer or building owner provides the structure for diverse entrance facilities into the building. In those instances where the customer or building owner requests the SHARP Option but does not provide the structure for diverse entrance facilities into the building, this feature provides a separate facility path for the protection system between the first utility vault outside the serving wire center (generally all facilities leave a wire center, to the first utility vault within the same conduit, cable, sheath, etc.) and the last terminal prior to the customer's premises.

The added protection is provided by ensuring that backup electronics and two physically separate facility paths are used in the provisioning of the service. A primary (or working) service path is established between the serving wire center and the customer-designated premises. A secondary (or protect path) is provisioned between the customer-designated premises and the serving wire center via a Company-designated alternate wire center. Should the working path or electronics fail, or the service performance become impaired (i.e., the bit error rate degenerates to less than or equal to 10 to the minus 6) the DS1 Service will automatically switch to the service protect path in order to maintain a near continuous flow of information between locations.

Due to constraints of the local network architecture as determined by the Company, there may be occasions where the service will be provisioned without the use of an alternate wire center.

The offering of SHARP contemplates the use of existing facilities. There may be occasions where the SHARP option is not available due to facilities limitations, or where it may be necessary to construct such facilities, either as normal or Special Construction. If Special Construction is involved using a route or type of facility other than that which the Company would normally use, an additional charge to the recurring monthly rates for service is applicable. The charge is equal to the difference between the charges of the specially constructed facilities and the recurring cost of the facilities the Company would have normally used. The additional charges will be designed to recover the additional costs over the requested service period of the Special Facilities Routing in order to allow all rates and charges to expire consecutively.

**Qwest Corporation
Private Line Transport Services
Catalog**

State of North Dakota
Effective: 10-16-2007

SECTION 5
Page 52
Release 2

5. SERVICES

5.2 SERVICE DESCRIPTIONS

5.2.10 DS1 SERVICE

E.3. (Cont'd)

(D)

(D)

Qwest Corporation
Private Line Transport Services
Catalog

State of North Dakota
 Effective: 04-19-2017

SECTION 5
 Page 53
 Release 2

5. SERVICES

5.2 SERVICE DESCRIPTIONS
5.2.10 DS1 SERVICE (Cont'd)

F. Service Information

SERVICE	NETWORK CHANNEL CODE	(T) (T)
1. End-Link or Mid-Link Application		
1.544 Mbit/s		
Month-to-Month		
1 Year	HC++	(T)
2 Year	HC++	
3 Year	HC++	
4 Year	HC++	
5 Year	HC++	
6 Year	HC++	
7 Year	HC++	
8 Year	HC++	
9 Year	HC++	
10 Year	HC++	
2. End-to-End Application		
1.544 Mbit/s		
Month-to-Month		
1 Year	HC++	(T)
2 Year	HC++	
3 Year	HC++	
4 Year	HC++	
5 Year	HC++	
6 Year	HC++	
7 Year	HC++	
8 Year	HC++	
9 Year	HC++	
10 Year	HC++	

Qwest Corporation
Private Line Transport Services
Catalog

State of North Dakota
Effective: 3-9-2001

SECTION 5
Page 54
Release 1

5. SERVICES

5.2 SERVICE DESCRIPTIONS
5.2.10 DS1 SERVICE (Cont'd)

G. Rate Conditions

This section contains specific terms and conditions governing the rates and charges for DS1 Service. The monthly rates and nonrecurring charges described as follows.

1. Monthly Rates

Monthly rates are flat rates that apply each month or fraction thereof that service is provided. These rates apply on a monthly basis. For billing purposes, each month is considered to have 30 days.

2. Nonrecurring Charges

Nonrecurring charges are one-time charges that apply for a specific work activity (i.e., installation or change to an existing service). The types of nonrecurring charges that apply for DS1 Service are: Channel Termination Initial and Subsequent, Transport Mileage, installation of Optional Features and Functions, and Service Rearrangements. Special construction charges as defined in 2.1.5 may also apply. Customers who order service under a Custom Arrangement, as defined in 3.2.3, may incur Special Construction Charges.

a. Channel Termination - Initial and Subsequent

An Initial or Subsequent nonrecurring charge applies for the installation of each Channel Termination and includes its predefined technical specifications and the facilities from the customer designated premises to the Serving Wire Center.

The Initial nonrecurring charge applies for work to be performed on one Channel Termination, at a customer-designated premises. The initial nonrecurring charge applies for new installation of a Channel Termination or for work to be performed on an existing Channel Termination.

Qwest Corporation
Private Line Transport Services
Catalog

State of North Dakota
Effective: 3-9-2001

SECTION 5
Page 55
Release 1

5. SERVICES

5.2 SERVICE DESCRIPTIONS

5.2.10 DS1 SERVICE

G.2.a. (Cont'd)

The Subsequent nonrecurring charge applies per Channel Termination, at one customer designated premises, when;

- At the same time as the initial Channel Termination is requested, a customer orders additional Channel Termination(s), due the same date, for the same type of service and exact NC/NCI combinations, at the same location.
- At the same time as a request for additional work on an existing Channel Termination, a customer requests the same additional work to be performed on identical existing Channel Termination(s), due the same date, for the same type of service and exact NC/NCI combinations, at the same location.

b. Transport Mileage

A nonrecurring charge applies for the installation of Transport Mileage which provides the transmission facilities between wire centers. This charge applies only when Transport Mileage is installed without a Channel Termination.

c. Installation of Optional Features and Functions

Nonrecurring charges apply for the installation of some of the optional features and functions available with DS1 Service. The charge applies whether the feature or function is installed coincident with the initial installation of service or at any time subsequent to the installation of the service, unless otherwise specified.

d. Service Rearrangements

Service rearrangements are changes to existing (installed) services which do not result in either a change in the minimum billing period requirements or a change in the physical location of the Channel Termination at a customer designated premises. The charge to the customer for the service rearrangement is dependent on whether the change is administrative only in nature or involves actual physical change to the service. Changes which result in the establishment of new minimum billing period obligations are treated as disconnects and new connects. Changes in the physical location of the Channel Termination are treated as moves and are described in 5.2.10.G.2.e.

- If the change involves the addition of an optional feature or function which has a separate nonrecurring charge, that nonrecurring charge will apply.

Qwest Corporation
Private Line Transport Services
Catalog

State of North Dakota
Effective: 04-19-2017

SECTION 5
Page 56
Release 2

5. SERVICES

5.2 SERVICE DESCRIPTIONS

5.2.10 DS1 SERVICE

G.2.d. (Cont'd)

- If the change involves reterminating an existing DS1 Channel Termination onto a spare channel of a higher capacity service, the Rollover nonrecurring charge, as specified in 3.2.2.L., preceding, will apply.
- If the change involves changing Frame Format or Line Code, (e.g., AMI to B8ZS line code, SuperFrame to ANSI Extended SuperFrame, or any frame format to Free-Frame, or vice versa), or if the customer wishes to add Clear Channel Capability to an existing DS1 Service, a Service Rearrangement nonrecurring charge will apply.

**NONRECURRING
CHARGE** (T)

Service Rearrangement, per
Channel Termination

\$140.00 (T)

- For all other changes, including the addition of optional features without separate nonrecurring charges (except for Clear Channel Capability), a charge equal to a Channel Termination nonrecurring charge will apply. Only one such charge will apply per service, per change.

e. Moves

A move involves a change in the physical location of one of the following:

- The Point of Termination at the customer's designated premises
- The customer's premises

The charges for the move are dependent on whether the move is to a new location within the same building or to a different building.

(1) Moves Within the Same Building or Between Buildings on the Same Premises

When the move is to a new location within the same premises or between buildings on the same premises, the move is the responsibility of the customer. There will be no change in the minimum billing period requirements.

Qwest Corporation
Private Line Transport Services
Catalog

State of North Dakota
Effective: 3-9-2001

SECTION 5
Page 57
Release 1

5. SERVICES

5.2 SERVICE DESCRIPTIONS

5.2.10 DS1 SERVICE

G.2.e. (Cont'd)

(2) Moves to a Different Building

A customer who has existing service may choose to move either a portion of or the entire existing service without incurring discontinuance charges provided the following conditions are met:

- Both the existing and the new services are provided solely by the Company,
- The customer's request for both the disconnect order for the existing service and the new connect order for the new service are received at the same time.
- The customer's request for the disconnect order for the existing service must reference the new connect order,
- The new service installation must be completed within thirty calendar days of the disconnection of the old service, unless the installation delay is caused by the Company,
- If the customer's service is under a Fixed Period Rate Plan, an amendment to the existing agreement must be completed. The original expiration date of the agreement is not affected, unless the customer wishes to extend the term of the agreement.

The monthly charges for the new service will be those charges in effect at the time the new service is installed. All nonrecurring charges apply for the new service. Should changes to either the disconnect order or the new connect order exclude one or more of the conditions above, applicable discontinuance and/or cancellation charges will be assessed, as specified in 2.4.6, preceding.

Qwest Corporation
Private Line Transport Services
Catalog

State of North Dakota
Effective: 3-9-2001

SECTION 5
Page 58
Release 1

5. SERVICES

5.2 SERVICE DESCRIPTIONS

5.2.10 DS1 SERVICE

G.2. (Cont'd)

f. Reestablishment of Service Following Fire, Flood or Other Occurrence

(1) Nonrecurring Charges do not Apply

Charges do not apply for the reestablishment of service following a fire, flood or other occurrence attributed to an Act of God provided that:

- The service is of the same type as was provided prior to the fire, flood or other occurrence,
- The service is for the same customer,
- The service is at the same location on the same premises,
- The reestablishment of service begins within 60 days after Company service is available. (The 60 day period may be extended a reasonable period if the renovation of the original location on the premises affected is not practical within the allotted time period.)

(2) Nonrecurring Charges Apply

Nonrecurring Charges apply for establishing service at a different location on the same premises or at a different premises pending reestablishment of service at the original location.

3. Mileage Measurement

The mileage to be used to determine the monthly charge for the Transport Mileage is calculated using the airline distance between Serving Wire Centers. The Serving Wire Center associated with a customer-designated premises is the Serving Wire Center from which the customer-designated premises would normally obtain dial tone.

Transport Mileage is shown in terms of mileage bands. To determine the charge to be billed, first compute the mileage using the V&H coordinates method, as set forth in the National Exchange Carrier Association Tariff F.C.C. No. 4, then find the band into which the computed mileage falls and apply the charges shown for that band. When the calculation results in a fraction of a mile, always round up to the next whole mile before determining the mileage band and applying the charges.

Qwest Corporation
Private Line Transport Services
Catalog

State of North Dakota
Effective: 3-9-2001

SECTION 5
Page 59
Release 1

5. SERVICES

5.2 SERVICE DESCRIPTIONS

5.2.10 DS1 SERVICE

G. Rate Conditions (Cont'd)

4. Fixed Period Rate Plans

- a. A customer may subscribe to a one-year through a ten-year Fixed Period Rate Plan. The minimum billing period for the rate plan is the same as the length of the rate plan selected by the customer.
- b. For customers that subscribe to a Fixed Period Rate Plan, the monthly charges for the entire fixed period will be protected from Company-initiated increases, at the charges in effect for the fixed period on the service date.
- c. If an Optional Feature is added to a circuit that is under an existing Fixed Period Rate Plan, the feature is charged for based on the length of the original Fixed Period Rate Plan.
- d. Services charged for under month-to-month billing may be upgraded to a Fixed Period Rate Plan at any time the customer chooses without incurring nonrecurring or discontinuance charges.
- e. A customer may renegotiate from an existing rate plan to a new rate plan at any time, with the condition that the new rate plan period must equal or exceed the number of months remaining in the existing rate plan.
- f. Customers with service under a Fixed-Period Rate Plan that is within 6 months of expiration may extend their Fixed-Period Rate Plan rates for a period of 12 months, by notifying the Company in writing of their intent to do so. The 12 month extension will begin upon expiration of the existing Fixed-Period Rate Plan. Extension of an existing Fixed-Period Rate Plan is available only for the original customer of record of the service.

At the end of the Fixed-Period Rate Plan or of the extension (whichever is applicable), the customer must choose to:

- Renew the service under a new Fixed-Period Rate Plan,
- Continue service under the month-to-month option, or
- Discontinue the service.

If the customer renews the service, the monthly charges for a new Fixed-Period Rate Plan will be the rates in effect, in the Catalog, on the renewal date. Should the customer not make a choice by the end of the existing Fixed-Period Rate Plan or extension period, the charges will automatically revert to the month-to-month option.

Qwest Corporation
Private Line Transport Services
Catalog

State of North Dakota
Effective: 3-9-2001

SECTION 5
Page 60
Release 1

5. SERVICES

5.2 SERVICE DESCRIPTIONS

5.2.10 DS1 SERVICE

G.4. (Cont'd)

g. Discontinuance of Service

- (1) If the customer terminates service, in whole or in part, at any time during the term of a Fixed Period Rate Plan, a termination charge may apply as specified in 2.4.6, preceding.
- (2) Discontinuance charges do not apply to Fixed Period Rate Plan services purchased by local, State or Federal government entities (or to customers that have purchased services solely for resale to local, State or Federal government entities) when they are discontinued prior to the completion of the Fixed Period Rate Plan only when all of the following conditions are met:
 - The service(s) purchased by the local, State or Federal government entity or customers that have purchased services for resale to local, State or Federal government entities are utilized solely for provision of services for that local, State or Federal government entity,
 - Funding for the service ordered by the authorized local, State or Federal government entity is included in the budget request for each fiscal period appropriation sufficient to cover the authorized local, State or Federal government entity's obligations under the Fixed Period Rate Plan for that fiscal period,

Qwest Corporation
Private Line Transport Services
Catalog

State of North Dakota
Effective: 3-9-2001

SECTION 5
Page 61
Release 1

5. SERVICES

5.2 SERVICE DESCRIPTIONS

5.2.10 DS1 SERVICE

G.4.g.(2) (Cont'd)

- Non-appropriation may not be used as a means of terminating the service to acquire a functionally similar product or service,
- The local, State or Federal government entity ordered the Fixed Period Rate Plan service under the good faith belief that moneys in amounts sufficient to discharge its obligations could and would lawfully be appropriated and be made available for this purpose and,
- The local, State or Federal government entity or the customer that ordered the service on their behalf must provide the Company notarized documents agreed upon by both the Company and the customer showing that the entity is allotted insufficient funds for the remainder of then current fiscal period (or for a succeeding fiscal period) by appropriation, appropriation limitation or grant to continue payments under the Fixed Period Rate Plan and has no other funding source lawfully available to it for such purpose. The service may be terminated by giving the Company not less than thirty (30) days written notice. Should the customer receive funding for the cancelled service prior to physical disconnect of service, the customer may cancel the disconnect order. Upon termination, the local, State or Federal government entity or the customer that ordered the service on their behalf shall pay all applicable monthly and nonrecurring charges incurred through the date of termination and through the end of the then current fiscal period to the extent of lawfully available funds.

Qwest Corporation
Private Line Transport Services
Catalog

State of North Dakota
Effective: 3-9-2001

SECTION 5
Page 62
Release 1

5. SERVICES

5.2 SERVICE DESCRIPTIONS

5.2.10 DS1 SERVICE

G. Rate Conditions (Cont'd)

5. Service Conversion

- a. An existing service that is provided under a Fixed Period Rate Plan, may be converted to another service without incurring a discontinuance charge, provided all the following conditions are met:
 - Both the existing and the new services are provided solely by the Company,
 - The customer's request for the disconnect of the existing service and the new connect of the new service are received at the same time,
 - The customer's request for the disconnect of the existing service must reference the requested new connect order,
 - The new service(s) installation must be completed within thirty calendar days of the disconnection of the old service(s), unless the installation delay is caused by the Company;
 - The total value of the new service agreement(s), excluding any special construction charges and any other nonrecurring charges, is equal to or greater than 115% of the remaining value of the existing agreement(s),
 - A new minimum service period goes into effect when the new service agreement term begins,
 - The customer agrees to pay any previously billed, but unpaid recurring, and any outstanding nonrecurring charges. These charges cannot be included as part of the new service agreement,
 - All applicable nonrecurring charges will be assessed for the new contracted service(s).

- b. Should the customer choose to convert a service provided under a Fixed Period Rate Plan, and move the service to new customer locations, discontinuance charges will not apply, provided all the conditions are met as set forth in G.2.d.(2).

Qwest Corporation
Private Line Transport Services
Catalog

State of North Dakota
Effective: 3-9-2001

SECTION 5
Page 63
Release 1

5. SERVICES

5.2 SERVICE DESCRIPTIONS (Cont'd)

5.2.11 DS3 SERVICE

A. Description

DS3 Service provides a high capacity channel for the transmission of 44.736 Mbit/s isochronous serial data having a line code of bipolar three zero substitution (B3ZS). DS3 Service is provided between customer designated premises, between a customer-designated premises and a Company Hub or between Company Hubs. DS3 Service is available utilizing an Electrical Interface. The interface will have the characteristics of its respective signal at the Point of Termination as described in the Technical Publication 77324.

B. Terms and Conditions

The terms and conditions specified in the DS3 Service Agreement, apply, in addition to the regulations set forth here and in Section 2 of this Catalog.

1. Availability

- DS3 Service is available only on a two-point basis, 24 hours per day, seven days a week.
- DS3 Service can only be provided from wire centers equipped for digital transmission and is subject to the technical limitations of the CO equipment used by the Company.
- Where suitable facilities are unavailable for provision of the service, special construction of the facilities may be necessary and will be charged for as specified in 2.1.5.
- A customer may request the facilities used to provide DS3 Service be specially routed. The regulations and charges for Facilities Protection - Special Facilities Routing (i.e., Avoidance and Diversity) are as set forth in 3.1.4.

Qwest Corporation
Private Line Transport Services
Catalog

State of North Dakota
Effective: 3-9-2001

SECTION 5
Page 64
Release 1

5. SERVICES

5.2 SERVICE DESCRIPTIONS

5.2.11 DS3 SERVICE

B. Terms and Conditions (Cont'd)

2. Payment Options

DS3 Service is offered on a month-to-month basis, and on one through ten year fixed periods as specified under DS1 Service. For Electrical Interface Capacity Channel Terminations larger than one DS3, the Capacity Channel Termination must be ordered before an associated Per DS3 Channel Termination can be ordered. In addition, the Capacity Channel Termination cannot be disconnected until all of the Per DS3 Channel Terminations are disconnected.

3. Electrical Interface Capacity Channel Terminations

Electrical Interface Capacity Channel Terminations will be provisioned utilizing Company provided equipment. Electrical Interface has eight different sizes of Capacity Channel Termination available. The capacities are capable of deriving the following number of DS3 signals, as described in PUB 77324.

**ELECTRICAL INTERFACE
DS3 CAPACITY CHANNEL
TERMINATION**

1	9
2	12
3	24
6	36

Qwest Corporation
Private Line Transport Services
Catalog

State of North Dakota
Effective: 3-9-2001

SECTION 5
Page 65
Release 1

5. SERVICES

5.2 SERVICE DESCRIPTIONS

5.2.11 DS3 SERVICE

B. Terms and Conditions (Cont'd)

4. Custom Offering

If the standard service, as described and offered, does not meet a particular customer requirement, the customer may request and the Company may develop a Custom offering. Special Construction Charges as defined in 2.1.5 may apply.

C. End-Link or Mid-Link Application

This application is intended for customers requiring Private Line Transport as part of an overall circuit, extending beyond the LATA. A Design Layout Report (DLR) is available to the customer to assist in their overall design. The network channel interface between the Company facility and the remainder of the overall circuit is referred to as the Mid User-POT (Point of Termination). The network channel interface that is at the terminating end of the overall circuit is referred to as the End User-POT.

D. End-To-End Application

This application is intended for customers requiring an overall Private Line Transport by the Company within the LATA. No DLR will be provided since the performance and maintenance will be the responsibility of the Company. The network channel interface at the terminating end of the overall circuit is referred to as the End User-POT.

Qwest Corporation
Private Line Transport Services
Catalog

State of North Dakota
Effective: 3-9-2001

SECTION 5
Page 66
Release 1

5. SERVICES

5.2 SERVICE DESCRIPTIONS

5.2.11 DS3 SERVICE (Cont'd)

E. Rate Categories

There are three basic rate categories which apply to DS3 Service:

- Channel Termination
- Transport Mileage
- Optional Features and Functions

1. Channel Termination

The Channel Termination provides for the communications path between the Demarcation Point at the customer-designated premises, and the Serving Wire Center of that premises. One Channel Termination charge applies per DS3 terminated at the Demarcation Point. For Capacity Channel Terminations larger than one DS3, the Capacity Channel Termination must be ordered before an associated Per DS3 Channel Termination can be ordered. These charges will apply even if the customer-designated premises and the Serving Wire Center are collocated in the same building. The Capacity Channel Termination can not be disconnected until all of the Per DS3 Channel Terminations are disconnected.

2. Transport Mileage

The Transport Mileage provides for the transmission facilities between the Serving Wire Centers associated with two customer-designated locations, between a Serving Wire Center associated with a customer location and a Company Hub or between Company Hubs. Transport Mileage is portrayed in mileage bands. There are two elements that apply for each band i.e., a fixed band and a per mile band. Transport Mileage is measured by airline miles between Serving Wire Centers via the V and H Coordinates Method, as set forth in the National Exchange Carrier Association Tariff F.C.C. No. 4.

Qwest Corporation
Private Line Transport Services
Catalog

State of North Dakota
Effective: 11-30-2007

SECTION 5
Page 67
Release 2

5. SERVICES

5.2 SERVICE DESCRIPTIONS

5.2.11 DS3 SERVICE

E. Rate Categories (Cont'd)

3. Optional Features and Functions

Optional features and functions are available where determined by the Company to be technically feasible.

a. Central Office Multiplexing

An arrangement that converts a 44.736 Mbit/s DS3 channel to twenty-eight 1.544 Mbit/s DS1 channels utilizing time division multiplexing. The twenty-eight channels may be further multiplexed utilizing DS1 multiplexers.

b. Command A Link

This option allows the customer to control the reconfiguration of a Private Line Service (digital or analog) on a near real-time basis, by means of the special provisioning of these services through a digital cross-connect device. Command A Link can accommodate the termination of circuits up to the 64 kbit/s[1], 1.544 Mbit/s[2], and 44.736 Mbit/s[3] signal levels. Customer access to the reconfiguration capability is via a Web Based Access arrangement and/or an Attendant Access arrangement. Terms, conditions, rates and charges for Command A Link are specified in 4.4, preceding.

(C)
|
(C)

Command A Link is available only in selected Serving Wire Centers.

[1] Applicable to Voice Grade and Digital Data Service.

[2] Applicable to Voice Grade, Digital Data Service and DS1 Service.

[3] Applicable to DS1 and DS3 Service.

Qwest Corporation
Private Line Transport Services
Catalog

State of North Dakota
 Effective: 04-19-2017

SECTION 5
 Page 68
 Release 2

5. SERVICES

5.2 SERVICE DESCRIPTIONS
5.2.11 DS3 SERVICE (Cont'd)

F. Service Information

SERVICE	NETWORK CHANNEL CODE	(T) (T)
1. End-Link or Mid-Link Application		
44.736 Mbit/s		
Month-to-Month	HF++	(T)
1 Year	HF++	
2 Year	HF++	
3 Year	HF++	
4 Year	HF++	
5 Year	HF++	
6 Year	HF++	
7 Year	HF++	
8 Year	HF++	
9 Year	HF++	
10 Year	HF++	
2. End-to-End Application		
44.736 Mbit/s		
Month-to-Month	HF++	(T)
1 Year	HF++	
2 Year	HF++	
3 Year	HF++	
4 Year	HF++	
5 Year	HF++	
6 Year	HF++	
7 Year	HF++	
8 Year	HF++	
9 Year	HF++	
10 Year	HF++	

Qwest Corporation
Private Line Transport Services
Catalog

State of North Dakota
Effective: 3-9-2001

SECTION 5
Page 69
Release 1

5. SERVICES

5.2 SERVICE DESCRIPTIONS

5.2.11 DS3 SERVICE (Cont'd)

G. Rate Conditions

This section contains specific terms and conditions governing the rates and charges for DS3 Service. The monthly rates and nonrecurring charges described as follows:

1. Monthly Rates

Monthly rates are flat rates that apply each month or fraction thereof that service is provided. These rates apply on a monthly basis. For billing purposes, each month is considered to have 30 days.

2. Nonrecurring Charges

Nonrecurring charges are one-time charges that apply for a specific work activity (i.e., installation or change to an existing service). The types of nonrecurring charges that apply for DS3 Service are: Channel Termination, installation of Optional Features and Functions, and Service Rearrangements. Special Construction Charges as defined in 2.1.5 may also apply. Customers who order service under a Custom Arrangement, as defined in 3.9.2.E., may incur Special Construction Charges.

5. SERVICES

5.2 SERVICE DESCRIPTIONS

5.2.11 DS3 SERVICE

G.2. (Cont'd)

a. Channel Termination

The nonrecurring charge applies for the installation of each Channel Termination and includes its predefined technical specifications and the facilities from the customer designated premises to the Serving Wire Center.

The nonrecurring charge applies for work to be performed on one Channel Termination, at a customer-designated premises. The nonrecurring charge applies for new installation of a Channel Termination or for work to be performed on an existing Channel Termination.

b. Installation of Optional Features and Functions

Nonrecurring charges apply for the installation of some of the optional features and functions available with DS3 Service. The charge applies whether the feature or function is installed coincident with the initial installation of service or at any time subsequent to the installation of the service, unless otherwise specified.

c. Service Rearrangements

Service rearrangements are changes to existing (installed) services which do not result in either a change in the minimum billing period requirements or a change in the physical location of the Channel Termination at a customer designated premises. The charge to the customer for the service rearrangement is dependent on whether the change is administrative only in nature or involves actual physical change to the service. Changes which result in the establishment of new minimum billing period obligations are treated as disconnects and new connects. Changes in the physical location of the Channel Termination are treated as moves and are described in 3.9.5.B.5.

- If the change involves the addition of an optional feature or function which has a separate nonrecurring charge, that nonrecurring charge will apply.

Qwest Corporation
Private Line Transport Services
Catalog

State of North Dakota
Effective: 3-9-2001

SECTION 5
Page 71
Release 1

5. SERVICES

5.2 SERVICE DESCRIPTIONS

5.2.11 DS3 SERVICE

G.2.c. (Cont'd)

- If the change involves reterminating an existing DS3 Channel Termination onto a spare channel of a higher capacity service, the Channel Termination nonrecurring charge will apply.
- For all other changes, including the addition of optional features without separate nonrecurring charges, a charge equal to a Channel Termination nonrecurring charge will apply. Only one such charge will apply per service, per change.

d. Administrative Changes

Administrative changes will be made without charge and are listed as follows:

- Change of customer circuit identification (circuit reference),
- Change of bill account number,
- Change of customer test line number,
- Change of jurisdiction,
- Supersedure. When a customer wishes to assume responsibility for a service which is already installed for another customer without any changes in the service, provided they meet the criteria established for a new customer.
- Change of customer name (i.e., the customer of record does not change but rather the customer of record changes its name--e.g., XYZ Company to XYZ Communications),
- Change of customer or customer's end user premises address when the change of address is not a result of a physical relocation of facilities,
- Change in billing data (name, address, or contact name or telephone number),
- Change of customer contact name or telephone number.

Qwest Corporation
Private Line Transport Services
Catalog

State of North Dakota
Effective: 3-9-2001

SECTION 5
Page 72
Release 1

5. SERVICES

5.2 SERVICE DESCRIPTIONS

5.2.11 DS3 SERVICE

G.2. (Cont'd)

e. Moves

A move involves a change in the physical location of one of the following:

- The Point of Termination at the customer's designated premises
- The customer's premises

The charges for the move are dependent on whether the move is to a new location within the same building or to a different building.

(1) **Moves Within the Same Building or Between Buildings on the Same Premises**

When the move is to a new location within the same premises or between buildings on the same premises, the move is the responsibility of the customer. There will be no change in the minimum billing period requirements.

Qwest Corporation
Private Line Transport Services
Catalog

State of North Dakota
Effective: 3-9-2001

SECTION 5
Page 73
Release 1

5. SERVICES

5.2 SERVICE DESCRIPTIONS

5.2.11 DS3 SERVICE

G.2.e. (Cont'd)

(2) Moves to a Different Building

A customer who has existing service may choose to move either a portion of or the entire existing service without incurring discontinuance charges provided the following conditions are met:

- Both the existing and the new services are provided solely by the Company,
- The customer's request for both the disconnect order for the existing service and the new connect order for the new service are received at the same time,
- The customer's request for the disconnect order for the existing service must reference the new connect order,
- The new service(s) installation must be completed within thirty calendar days of the disconnection of the old service(s), unless the installation delay is caused by the Company;
- If the customer's service is under a Fixed Period Rate Plan, an amendment to the existing agreement must be completed. The original expiration date of the agreement is not affected, unless the customer wishes to extend the term of the agreement.

The monthly charges for the new service will be those charges in effect at the time the new service is installed. All nonrecurring charges apply for the new service. Should changes to either the disconnect order or the new connect order exclude one or more of the conditions above, applicable discontinuance and/or cancellation charges will be assessed, as specified in 2.4.6, preceding.

Qwest Corporation
Private Line Transport Services
Catalog

State of North Dakota
Effective: 5-10-2004

SECTION 5
Page 74
Release 2[1]

5. SERVICES

5.2 SERVICE DESCRIPTIONS

5.2.11 DS3 SERVICE

G. Rate Conditions (Cont'd)

3. Fixed Period Rate Plans

A customer must initially subscribe to a one through a ten year Fixed Period Rate Plan. A month-to-month option is available only after the customer completes the initial Fixed Period Rate Plan. The minimum Fixed Period Rate Plan is one year.

All other terms and conditions for Fixed Period Rate Plans for DS3 Service are the same as those specified for DS1 Service.

4. Service Conversion

Service Conversion for DS3 Service is offered under the same terms and conditions as those specified for DS1 Service.

[1] This page cancels Pages 75 through 82, Release 1.

(N)

**Qwest Corporation
Private Line Transport Services
Catalog**

State of North Dakota
Effective: 9-15-2003

SECTION 105
Index Page 1
Release 4

105. OBSOLETE SERVICES

SUBJECT	PAGE
DC Line Power.....	4
Direct Routed Channels	7
DS1 Service	4
General.....	1
Miscellaneous Services	5
Service Channels.....	6
Voice Grade Service.....	1

(D)

Qwest Corporation
Private Line Transport Services
Catalog

SECTION 105

State of North Dakota
Effective: 12-1-2001

Page 1
Release 2

105. OBSOLETE SERVICES

105.1 GENERAL

Obsolete Services are certain items of service and equipment previously offered elsewhere. They will not be furnished as new items of service to any customer or applicant except where they are required to fully utilize the installed common equipment capacities of existing systems.

At the discretion of the Company, the items of service and equipment listed herein which were furnished prior to the date such items became obsolete, hereunder, may be continued in service only if they remain on the same premises for the same customer, and the Company is able to maintain such items without unreasonable expense and is able to obtain repair parts from existing or recovered stock.

105.2 SERVICE DESCRIPTIONS

(M)

105.2.2 VOICE GRADE SERVICE

(N)

A. Channel Performance (CP)

	USOC	MONTHLY RATE	
1. End-To-End, per termination			
• Voice Grade 32			(N)
- Code-select ringdown	PCWHX	\$13.00	(T-M1)

(M) Material moved from Page 2.

(M1) Material moved from 6.2.

NOTICE
THE INFORMATION CONTAINED IN THIS DOCUMENT IS SUBJECT TO CHANGE.

**Qwest Corporation
Private Line Transport Services
Catalog**

State of North Dakota
Effective: 9-15-2003

SECTION 105
Page 2
Release 3

105. OBSOLETE SERVICES

105.2 SERVICE DESCRIPTIONS (Cont'd)

(D)

**Qwest Corporation
Private Line Transport Services
Catalog**

State of North Dakota
Effective: 9-15-2003

SECTION 105
Page 3
Release 3

105. OBSOLETE SERVICES

105.2 SERVICE DESCRIPTIONS (Cont'd)

(D)

Qwest Corporation
Private Line Transport Services
Catalog

State of North Dakota
Effective: 3-9-2001

SECTION 105
Page 4
Release 1

105. OBSOLETE SERVICES

105.2 SERVICE DESCRIPTIONS (Cont'd)

105.2.10 DS1 SERVICE

A. DC Line Power[1]

DC Line Power provides a DC connection between the simplexes of the transmit and receive pairs, and provides 60mA from a constant current source. The connection will be at the customer end user's network interface, and in association with the DU network channel interface code. DC Line Power is available only when technically feasible.

	USOC	NONRECURRING CHARGE	MONTHLY RATE
1. DC Line Power, per termination	LNY	-	\$5.00

[1] This offering is limited to existing customers as December 1, 1995.

**Qwest Corporation
Private Line Transport Services
Catalog**

State of North Dakota
Effective: 10-1-2001

SECTION 105
Page 5
Release 2

105. OBSOLETE SERVICES

105.15 MISCELLANEOUS SERVICES

(D)

Qwest Corporation
Private Line Transport Services
Catalog

State of North Dakota
Effective: 10-1-2001

SECTION 105
Page 6
Release 2

105. OBSOLETE SERVICES

105.15 MISCELLANEOUS SERVICES (Cont'd)

A. Service Channel

(T)

1. Service Channels are private line channels and facilities provided by the Company to serve additional buildings on the same continuous property through Company facilities. This offering is limited to customers with facilities in place prior to November 29, 1988. These channels would be in cable facilities that also provide exchange service to other than the property owner and the facility would not be relinquished by the Company. The cable facility would traverse the same continuous property. New installations and additions or moves of existing installations are not permitted.

2. Rates and Charges

	USOC	MONTHLY RATE
• Service Channel	1LTBC	\$2.00

Qwest Corporation
Private Line Transport Services
Catalog

State of North Dakota
Effective: 10-1-2001

SECTION 105
Page 7
Release 2[1]

105. OBSOLETE SERVICES

105.15 MISCELLANEOUS SERVICES (Cont'd)

B. Direct Routed Channels

(T)

1. Description

Direct Route Channels are dedicated facilities provided at the option of the Company between two customers' locations not routed through the serving wire center. Existing customers will continue to be provided service until the dedicated facilities are fully utilized.

2. Rates and Charges

- a. The distance between the customers' locations is billed on 150 feet increments.

	USOC	NONRECURRING CHARGE	MONTHLY RATE	
• Each channel, per 150 feet or fraction thereof				
- DC Channel				
- Voice	1LMFK	-	\$1.40	
- 2 wire	1LLBD	-	1.40	(D)
- Data				
- 2 wire	1L6BD	-	1.40	
- 4 wire	1L6DD	-	2.75	(D)

[1] This page cancels Page 8, Release 1.

**Qwest Corporation d/b/a CenturyLink QC
Private Line Transport Services
Catalog**

State of North Dakota
Effective: 12-01-2020

SECTION 6
Index Page 1
Release 4

6. RATES AND CHARGES

SUBJECT	PAGE	
Analog and Digital Data Service - GRANDFATHERED	1	(C)
Channel Performance	2	
DS1 Service	24	
DS3 Service	80	
Network Access Channel.....	1	
Optional Features and Functions.....	13	
Service Provisioning Charge	1	
Transport Mileage	8	

Qwest Corporation d/b/a CenturyLink QC
Private Line Transport Services
Catalog

State of North Dakota
Effective: 12-01-2020

SECTION 6
Page 1
Release 5

6. RATES AND CHARGES

6.1 ANALOG AND DIGITAL DATA SERVICE[1] (C)

6.1.1 SERVICE PROVISIONING CHARGE

**NONRECURRING
CHARGE**

6. Applicable to Low Speed Data, Voice Grade, Audio, Foreign Exchange, Foreign Central Office, Exchange Service Extensions, Telephone Answering Service, and Digital Data Service

- Initial \$260.00
- Subsequent 95.00

6.1.2 NETWORK ACCESS CHANNEL (NAC)

**NONRECURRING
CHARGE MONTHLY
RATE**

- Per termination
- Two-wire[2] - \$32.00 (T)
- Four-wire[3] - 64.00 (T)

[1] Effective December 1, 2020 Analog and Digital Data Services are grandfathered. Availability to current customers is limited to circuits in service at existing locations. (N)

[2] Not applicable to Digital Data Service. (T)

[3] Not applicable to Audio, Foreign Exchange, Foreign Central Office, Exchange Service Extensions, and Telephone Answering Service. (T)

ND2020-13

NOTICE
THE INFORMATION CONTAINED IN THIS DOCUMENT IS SUBJECT TO CHANGE.

Qwest Corporation d/b/a CenturyLink QC
Private Line Transport Services
Catalog

State of North Dakota
 Effective: 12-01-2020

SECTION 6
 Page 2
 Release 4

6. RATES AND CHARGES

6.1 ANALOG AND DIGITAL DATA SERVICE [1] (Cont'd) (C)

6.1.3 CHANNEL PERFORMANCE (CP)

	NONRECURRING CHARGE	MONTHLY RATE
A. Low Speed Data Service		
1. End-Link or Mid-Link, per termination		
• TG1	\$30.00	\$35.00
• Custom	ICB	ICB
2. End-To-End, per termination		
• LS31 Control Status Channel	30.00	12.50
• LS31 McCulloh Alarm-Type	30.00	9.00
• LS31 DC Channel	30.00	5.00
• LS31 Telegraph		
- 0 to 75 baud	30.00	17.00
- 0 to 150 baud	30.00	21.50
• Custom	ICB	ICB
B. Voice Grade Service		
1. End-Link or Mid-Link, per termination		
• Voice Grade 2		
- No Signaling	30.00	13.00
- Loop-Start Signaling		
- Type - LA	30.00	15.00
- Type - LB	30.00	15.00
- Type - LC	30.00	15.00
- Type - LO	30.00	15.00
- Type - LS	30.00	15.00

[1] Effective December 1, 2020 Analog and Digital Data Services are grandfathered. (N)
Availability to current customers is limited to circuits in service at existing |
locations. (N)

Qwest Corporation d/b/a CenturyLink QC
Private Line Transport Services
Catalog

State of North Dakota
Effective: 12-01-2020

SECTION 6
Page 3
Release 5

6. RATES AND CHARGES

6.1 ANALOG AND DIGITAL DATA SERVICE [1]

(C)

6.1.3 CHANNEL PERFORMANCE (CP)

B.1. (Cont'd)

	NONRECURRING CHARGE	MONTHLY RATE
• Voice Grade 6		
- Data Stream	\$30.00	\$21.00
• Voice Grade 7		
- No Signaling	30.00	13.70
- Loop-Start Signaling		
- Type – LA	30.00	23.00
- Type – LB	30.00	23.00
- Type – LC	30.00	16.45
- Type – LO	30.00	13.30
- Type – LS	30.00	17.15
- Ground-Start Signaling	30.00	13.70
- E & M Signaling	30.00	31.50
- SF Signaling	30.00	20.00
• Voice Grade 12		
- Data Stream	30.00	22.00
• Voice Grade Custom	ICB	ICB

[1] Effective December 1, 2020 Analog and Digital Data Services are grandfathered. Availability to current customers is limited to circuits in service at existing locations.

(N)
|
(N)

ND2020-13

NOTICE
THE INFORMATION CONTAINED IN THIS DOCUMENT IS SUBJECT TO CHANGE.

Qwest Corporation d/b/a CenturyLink QC
Private Line Transport Services
Catalog

State of North Dakota
 Effective: 12-01-2020

SECTION 6
 Page 4
 Release 45

6. RATES AND CHARGES

6.1 ANALOG AND DIGITAL DATA SERVICE [1] (C)

6.1.3 CHANNEL PERFORMANCE (CP)

B. Voice Grade Service (Cont'd)

	NONRECURRING CHARGE	MONTHLY RATE	
2. End-To-End, per termination			
• Voice Grade 32			
- No Signaling	\$30.00	\$ 9.00	
- Loop-Start Signaling			
- Type – LA	30.00	10.85	
- Type – LB	30.00	9.75	
- Type – LC	30.00	9.50	
- Type – LG	30.00	16.85	
- Type – LO	30.00	9.50	
- Type – LS	30.00	9.70	
- Auto ringdown	30.00	13.00	
• Voice Grade 33			
- No Signaling	30.00	11.25	
- Ground-Start Signaling	30.00	11.00	
- E&M Signaling	30.00	17.50	
- Reverse Battery Signaling[1]	30.00	10.00	(T)
• Voice Grade 36			
- Data Stream	30.00	15.50	
• Voice Grade Custom	ICB	ICB	

[1] Effective December 1, 2020 Analog and Digital Data Services are grandfathered. (N)
Availability to current customers is limited to circuits in service at existing
locations. |
(N)

[2] Available to Radio Common Carriers within the same wire center only. (T)

Qwest Corporation d/b/a CenturyLink QC
Private Line Transport Services
Catalog

State of North Dakota
 Effective: 12-01-2020

SECTION 6
 Page 5
 Release 5

6. RATES AND CHARGES

6.1 ANALOG AND DIGITAL DATA SERVICE [1] (C)

6.1.3 CHANNEL PERFORMANCE (CP) (Cont'd)

	NONRECURRING CHARGE	MONTHLY RATE	
2. Audio Service			
2. End-Link or Mid-Link, per termination			(T)
• AP4 (15.0 kHz)	\$30.00	\$45.00	
• Custom	ICB	ICB	
2. End-To-End, per termination			
• AP31 (3.0 kHz) non-equalized	30.00	15.00	
• AP32 (5.0 kHz) equalized	30.00	22.00	
• AP33 (8.0 kHz) equalized	30.00	28.00	
• AP34 (15.0 kHz) equalized	30.00	45.00	
• Custom	ICB	ICB	

[1] Effective December 1, 2020 Analog and Digital Data Services are grandfathered. Availability to current customers is limited to circuits in service at existing locations. (N)
 |
 (N)

ND2020-13

Qwest Corporation d/b/a CenturyLink QC
Private Line Transport Services
Catalog

State of North Dakota
 Effective: 12-01-2020

SECTION 6
 Page 6
 Release 6

6. RATES AND CHARGES

6.1 ANALOG AND DIGITAL DATA SERVICE [1]
6.1.3 CHANNEL PERFORMANCE (CP) (Cont'd)

(C)

	NONRECURRING CHARGE	MONTHLY RATE
D. Foreign Exchange Service (FX), per termination		
• Loop-Start Signaling	\$ 30.00	\$10.50
• Ground-Start Signaling	30.00	10.50
• Reverse Battery Signaling	30.00	10.50
E. Foreign Central Office Service (FCO), per termination		
• Loop-Start Signaling	30.00	10.00
• Ground-Start Signaling	30.00	10.00
• Reverse Battery Signaling	30.00	10.00
F. Exchange Service Extensions (ESEs), per termination		
• Different Wire Center	30.00	11.00
• Same Wire Center	30.00	11.00
G. Telephone Answering Service (TAS), per termination		
• Different Wire Center	30.00	11.00
• Same Wire Center	30.00	11.00

[1] Effective December 1, 2020 Analog and Digital Data Services are grandfathered. Availability to current customers is limited to circuits in service at existing locations.

(N)
 |
 (N)

ND2020-13

NOTICE
THE INFORMATION CONTAINED IN THIS DOCUMENT IS SUBJECT TO CHANGE.

**Qwest Corporation d/b/a CenturyLink QC
Private Line Transport Services
Catalog**

State of North Dakota
Effective: 12-01-2020

SECTION 6
Page 7
Release 4

6. RATES AND CHARGES

6.1 ANALOG AND DIGITAL DATA SERVICE [1]

6.1.3 CHANNEL PERFORMANCE (CP) (Cont'd)

(C)

	NONRECURRING CHARGE	MONTHLY RATE
--	--------------------------------	-------------------------

H. Digital Data Service

2. End-Link or Mid-Link,
per termination

• 2.4 kbps	\$40.00	\$35.00	
• 4.8 kbps	40.00	35.00	
• 9.6 kbps	40.00	45.00	
• 19.2 kbps	40.00	45.00	
• 56 kbps	40.00	55.00	
• 64 kbps	40.00	55.00	
• Custom	[1]	[1]	(T)

2. End-to-End, per termination

• 2.4 kbps	40.00	35.00	
• 4.8 kbps	40.00	35.00	
• 9.6 kbps	40.00	45.00	
• 19.2 kbps	40.00	45.00	
• 56 kbps	40.00	55.00	
• 64 kbps	40.00	55.00	
• Custom	[1]	[1]	(T)

[1] Effective December 1, 2020 Analog and Digital Data Services are grandfathered. Availability to current customers is limited to circuits in service at existing locations. (N)
|
(N)

[2] Special Construction Charges as defined in 4.1.6 apply. (T)

ND2020-13

NOTICE
THE INFORMATION CONTAINED IN THIS DOCUMENT IS SUBJECT TO CHANGE.

**Qwest Corporation d/b/a CenturyLink QC
Private Line Transport Services
Catalog**

State of North Dakota
Effective: 12-01-2020

SECTION 6
Page 8
Release 5

6. RATES AND CHARGES

A.1 ANALOG AND DIGITAL DATA SERVICE [1] (Cont'd) (C)

A.1.4 TRANSPORT MILEAGE TM

	NONRECURRING CHARGE	MONTHLY RATE
A. Applicable to Low Speed Data, Voice Grade, Audio (AP31), Foreign Exchange, Foreign Central Office, Exchange Service Extensions, and Telephone Answering Service		
Mileage Bands		
• Over 0 to 8		
- Fixed	\$35.00	\$23.00
- Per mile	-	1.55
• Over 8 to 25		
- Fixed	35.00	23.00
- Per mile	-	1.55
• Over 25 to 50		
- Fixed	35.00	23.00
- Per mile	-	1.55
• Over 50		
- Fixed	35.00	23.00
- Per mile	-	1.55

**[1] Effective December 1, 2020 Analog and Digital Data Services are grandfathered. Availability to current customers is limited to circuits in service at existing locations. (N)
|
(N)**

ND2020-13

Qwest Corporation d/b/a CenturyLink QC
Private Line Transport Services
Catalog

State of North Dakota
 Effective: 12-01-2020

SECTION 6
 Page 9
 Release 5

6. RATES AND CHARGES

6.1 ANALOG AND DIGITAL DATA SERVICE [1]

6.1.4 TRANSPORT MILEAGE™ (Cont'd)

(C)

	NONRECURRING CHARGE	MONTHLY RATE
1. Audio Service		
1. AP32		
Mileage Bands		
• Over 0 to 8		
- Fixed	\$35.00	\$45.00
- Per mile	-	2.50
• Over 8 to 25		
- Fixed	35.00	45.00
- Per mile	-	2.70
• Over 25 to 50		
- Fixed	35.00	45.00
- Per mile	-	2.90
• Over 50		
- Fixed	35.00	45.00
- Per mile	-	3.10

[1] Effective December 1, 2020 Analog and Digital Data Services are grandfathered. Availability to current customers is limited to circuits in service at existing locations.

(N)
 |
 (N)

Qwest Corporation d/b/a CenturyLink QC
Private Line Transport Services
Catalog

State of North Dakota
 Effective: 12-01-2020

SECTION 6
 Page 10
 Release 5

2. RATES AND CHARGES

6.1 ANALOG AND DIGITAL DATA SERVICE

(T)

6.1.4 TRANSPORT MILEAGE™

B. Audio Service (Cont'd)

	NONRECURRING CHARGE	MONTHLY RATE
3. AP33		
Mileage Bands		
• Over 0 to 8		
- Fixed	\$35.00	\$69.00
- Per mile	-	3.75
• Over 8 to 25		
- Fixed	35.00	69.00
- Per mile	-	4.05
• Over 25 to 50		
- Fixed	35.00	69.00
- Per mile	-	4.35
• Over 50		
- Fixed	35.00	69.00
- Per mile	-	4.65

[1] Effective December 1, 2020 Analog and Digital Data Services are grandfathered. Availability to current customers is limited to circuits in service at existing locations.

(N)
 |
 (N)

ND2020-13

Qwest Corporation d/b/a CenturyLink QC
Private Line Transport Services
Catalog

State of North Dakota
 Effective: 12-01-2020

SECTION 6
 Page 11
 Release 5

6. RATES AND CHARGES

6.1 ANALOG AND DIGITAL DATA SERVICE [1]

(C)

6.1.4 TRANSPORT MILEAGE™

B. Audio Service (Cont'd)

	NONRECURRING CHARGE	MONTHLY RATE
4. AP4 or AP34		
Mileage Bands		
• Over 0 to 8		
- Fixed	\$35.00	\$135.00
- Per mile	-	5.60
• Over 8 to 25		
- Fixed	35.00	135.00
- Per mile	-	6.00
• Over 25 to 50		
- Fixed	35.00	135.00
- Per mile	-	6.50
• Over 50		
- Fixed	35.00	135.00
- Per mile	-	6.90

[1] Effective December 1, 2020 Analog and Digital Data Services are grandfathered. Availability to current customers is limited to circuits in service at existing locations.

(N)
 |
 (N)

ND2020-13

**Qwest Corporation d/b/a CenturyLink QC
Private Line Transport Services
Catalog**

State of North Dakota
Effective: 12-01-2020

SECTION 6
Page 12
Release 5

6. RATES AND CHARGES

6.1 ANALOG AND DIGITAL DATA SERVICE [1]

(C)

6.1.4 TRANSPORT MILEAGE (TM) (Cont'd)

	NONRECURRING CHARGE	MONTHLY RATE
C. Applicable to Digital Data Service		
Mileage Bands		
• Over 0 to 8		
- Fixed	\$35.00	\$35.00
- Per mile	-	1.55
• Over 8 to 25		
- Fixed	35.00	35.00
- Per mile	-	1.55
• Over 25 to 50		
- Fixed	35.00	35.00
- Per mile	-	1.55
• Over 50		
- Fixed	35.00	35.00
- Per mile	-	1.55

[1] Effective December 1, 2020 Analog and Digital Data Services are grandfathered. Availability to current customers is limited to circuits in service at existing locations.

(N)
|
(N)

ND2020-13

Qwest Corporation d/b/a CenturyLink QC
Private Line Transport Services
Catalog

State of North Dakota
Effective: 12-01-2020

SECTION 6
Page 13
Release 5

6. RATES AND CHARGES

6.1 ANALOG AND DIGITAL DATA SERVICE [1] (Cont'd)

(C)

6.1.5 OPTIONAL FEATURES AND FUNCTIONS

	NONRECURRING CHARGE	MONTHLY RATE
A. Low Speed Data Service		
1. Bridging		
• McCulloh Bridging, per port	\$10.00	\$ 5.00
• Telegraph Bridging, per port		
- 0 to 75 baud	10.00	15.00
- 0 to 150 baud	10.00	52.00
• Direct Bridging, per port	10.00	5.00

[1] Effective December 1, 2020 Analog and Digital Data Services are grandfathered. Availability to current customers is limited to circuits in service at existing locations.

(N)
|
(N)

ND2020-13

NOTICE
THE INFORMATION CONTAINED IN THIS DOCUMENT IS SUBJECT TO CHANGE.

Qwest Corporation d/b/a CenturyLink QC
Private Line Transport Services
Catalog

State of North Dakota
 Effective: 12-01-2020

SECTION 6
 Page 14
 Release 54

6. RATES AND CHARGES

6.1 ANALOG AND DIGITAL DATA SERVICE [1] (C)

6.1.5 OPTIONAL FEATURES AND FUNCTIONS (Cont'd)

	NONRECURRING CHARGE	MONTHLY RATE
B. Voice Grade Service		
1. Bridging		
• Resistive Bridging (Voice/Data), per port		
- Two-wire	\$10.00	\$ 8.00
- Four-wire	10.00	8.00
• Bridge Lifter, per port	10.00	5.00
2. Conditioning, per NAC		
• End-to-End Application		
- C1 Conditioning	15.00	5.00
- C2 Conditioning	15.00	5.00
- C4 Conditioning	15.00	5.00
- D1 Conditioning	15.00	5.00
3. Data Channel Terminating Equipment, per NAC[2]		
• Central Office Powered Data Equalization with 2713 Hz tone	30.00	1.25
4. Customer Specified Levels, per NAC		
	30.00	5.00

[1] Effective December 1, 2020 Analog and Digital Data Services are grandfathered. Availability to current customers is limited to circuits in service at existing locations. (N)
 |
 (N)

[2] The nonrecurring charge applies when adding this feature on subsequent order activity only. (T)

ND2020-13

NOTICE
 THE INFORMATION CONTAINED IN THIS DOCUMENT IS SUBJECT TO CHANGE.

Qwest Corporation d/b/a CenturyLink QC
Private Line Transport Services
Catalog

State of North Dakota
Effective: 12-01-2020

SECTION 6
Page 15
Release 5

6. RATES AND CHARGES

6.1 ANALOG AND DIGITAL DATA SERVICE[1]

(C)

6.1.5 OPTIONAL FEATURES AND FUNCTIONS (Cont'd)

	NONRECURRING CHARGE	MONTHLY RATE
C. Audio Service		
1. Bridging, per port		
• AP31 - 3.5/3.0 kHz	\$10.00	\$10.00
• AP32 - 5.0 kHz	10.00	20.00
• AP33 - 8.0 kHz	10.00	30.00
• AP4/AP34 - 15.0 kHz	10.00	40.00
D. Telephone Answering Service		
• Telephone Answering Service with Privacy (Key Arrangements)		
- CO relay, each	-	8.00

[1] Effective December 1, 2020 Analog and Digital Data Services are grandfathered. Availability to current customers is limited to circuits in service at existing locations.

(N)
|
(N)

ND2020-13

NOTICE
THE INFORMATION CONTAINED IN THIS DOCUMENT IS SUBJECT TO CHANGE.

**Qwest Corporation d/b/a CenturyLink QC
Private Line Transport Services
Catalog**

State of North Dakota
Effective: 12-01-2020

SECTION 6
Page 16
Release 4

6. RATES AND CHARGES

6.1 ANALOG AND DIGITAL DATA SERVICE [1] (Cont'd)

(C)

[1] Effective December 1, 2020 Analog and Digital Data Services are grandfathered. Availability to current customers is limited to circuits in service at existing locations.

(N)
|
(N)

ND2020-13

Qwest Corporation d/b/a CenturyLink QC
Private Line Transport Services
Catalog

State of North Dakota
 Effective: 12-01-2020

SECTION 6
 Page 17
 Release 5

6. RATES AND CHARGES

6.1 ANALOG AND DIGITAL DATA SERVICE [1] (C)

6.1.5 OPTIONAL FEATURES AND FUNCTIONS (Cont'd)

	NONRECURRING CHARGE	MONTHLY RATE	
E. Digital Data Service			
1. Bridging, per port	\$ 15.00	\$25.00	
2. Secondary Channel, per point of termination[2]	120.00	15.00	(T)
3. Central Office Multiplexing, per arrangement[3]			(T)
• DS0 to Subrates			
- Up to twenty 2.4 kbps services	100.00	90.00	
- Up to ten 4.8 kbps services	90.00	80.00	
- Up to five 9.6 kbps services	80.00	70.00	
4. Central Office Multiplexer to Multiplexer Connecting Arrangement, per arrangement			
• Subrate to Subrate	12.00	10.00	
• Subrate to Subrate with Secondary Channel	12.00	10.00	
• DS0 to DS0	12.00	10.00	
• DS0 to DS0 with Secondary Channel	12.00	10.00	

[1] Effective December 1, 2020 Analog and Digital Data Services are grandfathered. Availability to current customers is limited to circuits in service at existing locations. (N)

[2] The nonrecurring charge applies when adding this feature on subsequent order activity only. (T)

[3] The nonrecurring charge applies when the Multiplexer is not installed at the same time as a DDS Network Access Channel. (T)

ND2020-13

NOTICE
 THE INFORMATION CONTAINED IN THIS DOCUMENT IS SUBJECT TO CHANGE.

**Qwest Corporation
Private Line Transport Services
Catalog**

State of North Dakota
Effective: 6-3-2005

SECTION 6
Page 18
Release 3

6. RATES AND CHARGES

6.4 RESERVED FOR FUTURE USE

(T)

(D)

(M)

(D)

(M) Material moved to Page 6.

NOTICE
THE INFORMATION CONTAINED IN THIS DOCUMENT IS SUBJECT TO CHANGE.

**Qwest Corporation
Private Line Transport Services
Catalog**

State of North Dakota
Effective: 6-3-2005

SECTION 6
Page 19
Release 3

6. RATES AND CHARGES

6.5 RESERVED FOR FUTURE USE

(T)

(D)

(M)

(M) Material moved to Page 6.

NOTICE
THE INFORMATION CONTAINED IN THIS DOCUMENT IS SUBJECT TO CHANGE.

**Qwest Corporation
Private Line Transport Services
Catalog**

State of North Dakota
Effective: 6-3-2005

SECTION 6
Page 20
Release 2

6. RATES AND CHARGES

6.6 RESERVED FOR FUTURE USE

(T)

(D)

(M)

(M) Material moved to Page 16.

NOTICE
THE INFORMATION CONTAINED IN THIS DOCUMENT IS SUBJECT TO CHANGE.

**Qwest Corporation
Private Line Transport Services
Catalog**

State of North Dakota
Effective: 6-3-2005

SECTION 6
Page 21
Release 3

6. RATES AND CHARGES

6.7 RESERVED FOR FUTURE USE

(T)

(D)

(M)

(M) Material moved to Page 7.

NOTICE
THE INFORMATION CONTAINED IN THIS DOCUMENT IS SUBJECT TO CHANGE.

**Qwest Corporation
Private Line Transport Services
Catalog**

State of North Dakota
Effective: 6-3-2005

SECTION 6
Page 22
Release 3

6. RATES AND CHARGES

6.8 RESERVED FOR FUTURE USE

(T)

(M)

(M1)

(M) Material moved to Page 12.

(M1) Material moved to Page 17.

NOTICE
THE INFORMATION CONTAINED IN THIS DOCUMENT IS SUBJECT TO CHANGE.

**Qwest Corporation
Private Line Transport Services
Catalog**

State of North Dakota
Effective: 6-3-2005

SECTION 6
Page 23
Release 2

6. RATES AND CHARGES

6.9 RESERVED FOR FUTURE USE

(T)

(M)

(M) Material moved to Page 17.

NOTICE
THE INFORMATION CONTAINED IN THIS DOCUMENT IS SUBJECT TO CHANGE.

Qwest Corporation
Private Line Transport Services
Catalog

State of North Dakota
Effective: 04-19-2017

SECTION 6
Page 24
Release 2

6. RATES AND CHARGES

6.10 DS1 SERVICE

When DS1 service is ordered, the rates and charges apply, as shown herein. Customers are required to sign a service agreement for one-year through ten-year service periods.

A. Month-to-Month

	NONRECURRING CHARGE	MONTHLY RATE	(T)
1. Channel Termination - Initial, per termination			
• 1 through 5 circuits	\$340.00	\$150.00	(T)
• 6 through 12 circuits	340.00	142.50	
• 13 through 18 circuits	340.00	138.75	
• 19 circuits and above	340.00	135.00	(T)
Channel Termination - Subsequent, per termination			
• 1 through 5 circuits	316.00	150.00	(T)
• 6 through 12 circuits	316.00	142.50	
• 13 through 18 circuits	316.00	138.75	
• 19 circuits and above	316.00	135.00	(T)

Qwest Corporation
Private Line Transport Services
Catalog

State of North Dakota
 Effective: 04-19-2017

SECTION 6
 Page 25
 Release 2

6. RATES AND CHARGES

6.10 DS1 SERVICE

A. Month-to-Month (Cont'd)

2. Transport Mileage

	NONRECURRING CHARGE[1]	MONTHLY RATE	(T)
a. 1 through 5 circuits			
Mileage Bands			
• Over 0 to 8			
- Fixed	\$285.00	\$150.00	(T)
- Per mile	-	11.00	(T)
• Over 8 to 25			
- Fixed	285.00	200.00	(T)
- Per mile	-	15.00	(T)
• Over 25 to 50			
- Fixed	285.00	250.00	(T)
- Per mile	-	17.00	(T)
• Over 50			
- Fixed	285.00	250.00	(T)
- Per mile	-	17.00	(T)

[1] Nonrecurring charges apply to Transport Mileage when installed without a Channel Termination.

Qwest Corporation
Private Line Transport Services
Catalog

State of North Dakota
 Effective: 04-19-2017

SECTION 6
 Page 26
 Release 2

6. RATES AND CHARGES

6.10 DS1 SERVICE

A.2. (Cont'd)

	NONRECURRING CHARGE[1]	MONTHLY RATE	(T)
b. 6 through 12 circuits			
Mileage Bands			
• Over 0 to 8			
- Fixed	\$285.00	\$142.50	(T)
- Per mile	-	10.45	(T)
• Over 8 to 25			
- Fixed	285.00	190.00	(T)
- Per mile	-	14.25	(T)
• Over 25 to 50			
- Fixed	285.00	237.50	(T)
- Per mile	-	16.15	(T)
• Over 50			
- Fixed	285.00	237.50	(T)
- Per mile	-	16.15	(T)
c. 13 through 18 circuits			
Mileage Bands			
• Over 0 to 8			
- Fixed	285.00	138.75	(T)
- Per mile	-	10.18	(T)
• Over 8 to 25			
- Fixed	285.00	185.00	(T)
- Per mile	-	13.88	(T)
• Over 25 to 50			
- Fixed	285.00	231.25	(T)
- Per mile	-	15.73	(T)
• Over 50			
- Fixed	285.00	231.25	(T)
- Per mile	-	15.73	(T)

[1] Nonrecurring charges apply to Transport Mileage when installed without a Channel Termination.

Qwest Corporation
Private Line Transport Services
Catalog

State of North Dakota
 Effective: 04-19-2017

SECTION 6
 Page 27
 Release 2

6. RATES AND CHARGES

6.10 DS1 SERVICE

A.2. (Cont'd)

	NONRECURRING CHARGE	MONTHLY RATE	(T)
d. 19 circuits and above			
Mileage Bands[1]			
• Over 0 to 8			
- Fixed	\$285.00	\$135.00	(T)
- Per mile	-	9.90	(T)
• Over 8 to 25			
- Fixed	285.00	180.00	(T)
- Per mile	-	13.50	(T)
• Over 25 to 50			
- Fixed	285.00	225.00	(T)
- Per mile	-	15.30	(T)
• Over 50			
- Fixed	285.00	225.00	(T)
- Per mile	-	15.30	(T)
3. Optional Features and Functions			
a. Central Office Multiplexing, per arrangement[2]			
• DS1 to Voice/Data	150.00	300.00	(T)
• DS1 to DS0	150.00	300.00	(T)

[1] Nonrecurring charges apply to Transport Mileage when installed without a Channel Termination.

[2] Nonrecurring charges apply when multiplexing is not installed at the same time as a Channel Termination.

Qwest Corporation
Private Line Transport Services
Catalog

State of North Dakota
 Effective: 04-19-2017

SECTION 6
 Page 28
 Release 2

6. RATES AND CHARGES

6.10 DS1 SERVICE

A.3. (Cont'd)

	NONRECURRING CHARGE	MONTHLY RATE	(T)
b. Central Office Multiplexer to Multiplexer Connecting Arrangement, per arrangement			
• Between two multiplexers at the DS1 level	\$30.00	\$ 5.00	(T)
• Between two multiplexers at the DS1 level and optioned for B8ZS line code	30.00	5.00	(T)
c. Clear Channel Capability, per termination			
• B8ZS	-	-	(T)
d. Central Office 1.544 Mbit/s Connecting Channel, per channel			
• Between two different 1.544 Mbit/s not installed as one service	30.00	3.00	(T)
e. Automatic Loop Transfer, per arrangement[1]	20.00	45.00	(T)

[1] An additional Channel Termination Charge will apply whenever the spare line is provided as a leg to the customer premises.

Qwest Corporation
Private Line Transport Services
Catalog

State of North Dakota
Effective: 04-19-2017

SECTION 6
Page 29
Release 3

6. RATES AND CHARGES

6.10 DS1 SERVICE

A.3. (Cont'd)

	NONRECURRING CHARGE	MONTHLY RATE	(T)
f. Self Healing Alternate Route Protection (SHARP), per channel termination[1]			
• 1 through 5 circuits	\$600.00	\$75.00	(T)
• 6 through 12 circuits	600.00	71.25	
• 13 through 18 circuits	600.00	69.11	
• 19 circuits and above	600.00	67.04	(T)

[1] Nonrecurring charges apply when the SHARP is not installed at the same time as a Channel Termination.

Qwest Corporation
Private Line Transport Services
Catalog

State of North Dakota
 Effective: 04-19-2017

SECTION 6
 Page 30
 Release 2

6. RATES AND CHARGES

6.10 DS1 SERVICE (Cont'd)

B. One-Year Contract

	NONRECURRING CHARGE	MONTHLY RATE	(T)
1. Channel Termination - Initial, per termination			
• 1 through 5 circuits	\$340.00	\$141.00	(T)
• 6 through 12 circuits	340.00	133.95	
• 13 through 18 circuits	340.00	130.43	
• 19 circuits and above	340.00	126.90	(T)
Channel Termination - Subsequent, per termination			
• 1 through 5 circuits	316.00	141.00	(T)
• 6 through 12 circuits	316.00	133.95	
• 13 through 18 circuits	316.00	130.43	
• 19 circuits and above	316.00	126.90	(T)
2. Transport Mileage[1]			
a. 1 through 5 circuits			
Mileage Bands			
• Over 0 to 8			
- Fixed	285.00	141.00	(T)
- Per mile	-	10.25	(T)
• Over 8 to 25			
- Fixed	285.00	179.50	(T)
- Per mile	-	14.10	(T)
• Over 25 to 50			
- Fixed	285.00	218.00	(T)
- Per mile	-	16.65	(T)
• Over 50			
- Fixed	285.00	218.00	(T)
- Per mile	-	16.65	(T)

[1] Nonrecurring charges apply to Transport Mileage when installed without a Channel Termination.

Qwest Corporation
Private Line Transport Services
Catalog

State of North Dakota
Effective: 04-19-2017

SECTION 6
Page 31
Release 2

6. RATES AND CHARGES

6.10 DS1 SERVICE

B.2. (Cont'd)

	NONRECURRING CHARGE[1]	MONTHLY RATE	(T)
b. 6 through 12 circuits			
Mileage Bands			
• Over 0 to 8			
- Fixed	\$285.00	\$133.95	(T)
- Per mile	-	9.74	(T)
• Over 8 to 25			
- Fixed	285.00	170.53	(T)
- Per mile	-	13.40	(T)
• Over 25 to 50			
- Fixed	285.00	207.10	(T)
- Per mile	-	15.82	(T)
• Over 50			
- Fixed	285.00	207.10	(T)
- Per mile	-	15.82	(T)
c. 13 through 18 circuits			
Mileage Bands			
• Over 0 to 8			
- Fixed	285.00	130.43	(T)
- Per mile	-	9.48	(T)
• Over 8 to 25			
- Fixed	285.00	166.04	(T)
- Per mile	-	13.04	(T)
• Over 25 to 50			
- Fixed	285.00	201.65	(T)
- Per mile	-	15.40	(T)
• Over 50			
- Fixed	285.00	201.65	(T)
- Per mile	-	15.40	(T)

[1] Nonrecurring charges apply to Transport Mileage when installed without a Channel Termination.

Qwest Corporation
Private Line Transport Services
Catalog

State of North Dakota
 Effective: 04-19-2017

SECTION 6
 Page 32
 Release 2

6. RATES AND CHARGES

6.10 DS1 SERVICE

B.2. (Cont'd)

	NONRECURRING CHARGE	MONTHLY RATE	(T)
d. 19 circuits and above			
Mileage Bands[1]			
• Over 0 to 8			
- Fixed	\$285.00	\$126.90	(T)
- Per mile	-	9.23	(T)
• Over 8 to 25			
- Fixed	285.00	161.55	(T)
- Per mile	-	12.69	(T)
• Over 25 to 50			
- Fixed	285.00	196.20	(T)
- Per mile	-	14.99	(T)
• Over 50			
- Fixed	285.00	196.20	(T)
- Per mile	-	14.99	(T)
3. Optional Features and Functions			
a. Central Office Multiplexing, per arrangement[2]			
• DS1 to Voice/Data	150.00	300.00	(T)
• DS1 to DS0	150.00	300.00	(T)

[1] Nonrecurring charges apply to Transport Mileage when installed without a Channel Termination.

[2] Nonrecurring charges apply when multiplexing is not installed at the same time as a Channel Termination.

Qwest Corporation
Private Line Transport Services
Catalog

State of North Dakota
 Effective: 04-19-2017

SECTION 6
 Page 33
 Release 2

6. RATES AND CHARGES

6.10 DS1 SERVICE

B.3. (Cont'd)

	NONRECURRING CHARGE	MONTHLY RATE	(T)
b. Central Office Multiplexer to Multiplexer Connecting Arrangement, per arrangement			
• Between two multiplexers at the DS1 level	\$30.00	\$ 5.00	(T)
• Between two multiplexers at the DS1 level and optioned for B8ZS line code	30.00	5.00	(T)
c. Clear Channel Capability, per termination			
• B8ZS	-	-	(T)
d. Central Office 1.544 Mbit/s Connecting Channel, per channel			
• Between two different 1.544 Mbit/s not installed as one service	30.00	3.00	(T)
e. Automatic Loop Transfer, per arrangement[1]	20.00	45.00	(T)

[1] An additional Channel Termination Charge will apply whenever the spare line is provided as a leg to the customer premises.

Qwest Corporation
Private Line Transport Services
Catalog

State of North Dakota
Effective: 04-19-2017

SECTION 6
Page 34
Release 3

6. RATES AND CHARGES

6.10 DS1 SERVICE

B.3. (Cont'd)

	NONRECURRING CHARGE	MONTHLY RATE	(T)
f. Self Healing Alternate Route Protection (SHARP), per channel termination[1]			
• 1 through 5 circuits	\$600.00	\$72.75	(T)
• 6 through 12 circuits	600.00	69.11	
• 13 through 18 circuits	600.00	67.04	
• 19 circuits and above	600.00	65.03	(T)

[1] Nonrecurring charges apply when the SHARP is not installed at the same time as a Channel Termination.

Qwest Corporation
Private Line Transport Services
Catalog

State of North Dakota
 Effective: 04-19-2017

SECTION 6
 Page 35
 Release 2

6. RATES AND CHARGES

6.10 DS1 SERVICE (Cont'd)

C. Two-Year Contract

	NONRECURRING CHARGE	MONTHLY RATE	(T)
1. Channel Termination - Initial, per termination			
• 1 through 5 circuits	\$340.00	\$133.95	(T)
• 6 through 12 circuits	340.00	127.25	
• 13 through 18 circuits	340.00	123.90	
• 19 circuits and above	340.00	120.56	(T)
Channel Termination - Subsequent, per termination			
• 1 through 5 circuits	316.00	133.95	(T)
• 6 through 12 circuits	316.00	127.25	
• 13 through 18 circuits	316.00	123.90	
• 19 circuits and above	316.00	120.56	(T)
2. Transport Mileage[1]			
a. 1 through 5 circuits			
Mileage Bands			
• Over 0 to 8			
- Fixed	285.00	133.95	(T)
- Per mile	-	9.74	(T)
• Over 8 to 25			
- Fixed	285.00	170.53	(T)
- Per mile	-	13.40	(T)
• Over 25 to 50			
- Fixed	285.00	207.10	(T)
- Per mile	-	15.82	(T)
• Over 50			
- Fixed	285.00	207.10	(T)
- Per mile	-	15.82	(T)

[1] Nonrecurring charges apply to Transport Mileage when installed without a Channel Termination.

Qwest Corporation
Private Line Transport Services
Catalog

State of North Dakota
Effective: 04-19-2017

SECTION 6
Page 36
Release 2

6. RATES AND CHARGES

6.10 DS1 SERVICE

C.2. (Cont'd)

	NONRECURRING CHARGE[1]	MONTHLY RATE	(T)
b. 6 through 12 circuits			
Mileage Bands			
• Over 0 to 8			
- Fixed	\$285.00	\$127.25	(T)
- Per mile	-	9.25	(T)
• Over 8 to 25			
- Fixed	285.00	162.00	(T)
- Per mile	-	12.73	(T)
• Over 25 to 50			
- Fixed	285.00	196.75	(T)
- Per mile	-	15.03	(T)
• Over 50			
- Fixed	285.00	196.75	(T)
- Per mile	-	15.03	(T)
c. 13 through 18 circuits			
Mileage Bands			
• Over 0 to 8			
- Fixed	285.00	123.90	(T)
- Per mile	-	9.01	(T)
• Over 8 to 25			
- Fixed	285.00	157.74	(T)
- Per mile	-	12.39	(T)
• Over 25 to 50			
- Fixed	285.00	191.57	(T)
- Per mile	-	14.63	(T)
• Over 50			
- Fixed	285.00	191.57	(T)
- Per mile	-	14.63	(T)

[1] Nonrecurring charges apply to Transport Mileage when installed without a Channel Termination.

Qwest Corporation
Private Line Transport Services
Catalog

State of North Dakota
 Effective: 04-19-2017

SECTION 6
 Page 37
 Release 2

6. RATES AND CHARGES

6.10 DS1 SERVICE

C.2. (Cont'd)

	NONRECURRING CHARGE	MONTHLY RATE	(T)
d. 19 circuits and above			
Mileage Bands[1]			
• Over 0 to 8			
- Fixed	\$285.00	\$120.56	(T)
- Per mile	-	8.76	(T)
• Over 8 to 25			
- Fixed	285.00	153.47	(T)
- Per mile	-	12.06	(T)
• Over 25 to 50			
- Fixed	285.00	186.39	(T)
- Per mile	-	14.24	(T)
• Over 50			
- Fixed	285.00	186.39	(T)
- Per mile	-	14.24	(T)
3. Optional Features and Functions			
a. Central Office Multiplexing, per arrangement[2]			
• DS1 to Voice/Data	150.00	285.00	(T)
• DS1 to DS0	150.00	285.00	(T)

[1] Nonrecurring charges apply to Transport Mileage when installed without a Channel Termination.

[2] Nonrecurring charges apply when multiplexing is not installed at the same time as a Channel Termination.

Qwest Corporation
Private Line Transport Services
Catalog

State of North Dakota
Effective: 04-19-2017

SECTION 6
Page 38
Release 2

6. RATES AND CHARGES

6.10 DS1 SERVICE

C.3. (Cont'd)

	NONRECURRING CHARGE	MONTHLY RATE	(T)
b. Central Office Multiplexer to Multiplexer Connecting Arrangement, per arrangement			
• Between two multiplexers at the DS1 level	\$30.00	\$ 5.00	(T)
• Between two multiplexers at the DS1 level and optioned for B8ZS line code	30.00	5.00	(T)
c. Clear Channel Capability, per termination			
• B8ZS	-	-	(T)
d. Central Office 1.544 Mbit/s Connecting Channel, per channel			
• Between two different 1.544 Mbit/s not installed as one service	30.00	3.00	(T)
e. Automatic Loop Transfer, per arrangement[1]	20.00	45.00	(T)

[1] An additional Channel Termination Charge will apply whenever the spare line is provided as a leg to the customer premises.

Qwest Corporation
Private Line Transport Services
Catalog

State of North Dakota
Effective: 04-19-2017

SECTION 6
Page 39
Release 3

6. RATES AND CHARGES

6.10 DS1 SERVICE

C.3. (Cont'd)

	NONRECURRING CHARGE	MONTHLY RATE	(T)
f. Self Healing Alternate Route Protection (SHARP), per channel termination[1]			
• 1 through 5 circuits	\$600.00	\$70.57	(T)
• 6 through 12 circuits	600.00	67.04	
• 13 through 18 circuits	600.00	65.03	
• 19 circuits and above	600.00	63.06	(T)

[1] Nonrecurring charges apply when the SHARP is not installed at the same time as a Channel Termination.

Qwest Corporation
Private Line Transport Services
Catalog

State of North Dakota
 Effective: 04-19-2017

SECTION 6
 Page 40
 Release 2

6. RATES AND CHARGES

6.10 DS1 SERVICE

D. Three-Year Contract

	NONRECURRING CHARGE	MONTHLY RATE	(T)
1. Channel Termination - Initial, per termination			
• 1 through 5 circuits	\$340.00	\$126.90	(T)
• 6 through 12 circuits	340.00	120.56	
• 13 through 18 circuits	340.00	117.38	
• 19 circuits and above	340.00	114.21	(T)
Channel Termination - Subsequent, per termination			
• 1 through 5 circuits	316.00	126.90	(T)
• 6 through 12 circuits	316.00	120.56	
• 13 through 18 circuits	316.00	117.38	
• 19 circuits and above	316.00	114.21	(T)
2. Transport Mileage[1]			
a. 1 through 5 circuits			
Mileage Bands			
• Over 0 to 8			
- Fixed	285.00	126.90	(T)
- Per mile	-	9.23	(T)
• Over 8 to 25			
- Fixed	285.00	161.55	(T)
- Per mile	-	12.69	(T)
• Over 25 to 50			
- Fixed	285.00	196.20	(T)
- Per mile	-	14.99	(T)
• Over 50			
- Fixed	285.00	196.20	(T)
- Per mile	-	14.99	(T)

[1] Nonrecurring charges apply to Transport Mileage when installed without a Channel Termination.

Qwest Corporation
Private Line Transport Services
Catalog

State of North Dakota
Effective: 04-19-2017

SECTION 6
Page 41
Release 2

6. RATES AND CHARGES

6.10 DS1 SERVICE

D.2. (Cont'd)

	NONRECURRING CHARGE[1]	MONTHLY RATE	(T)
b. 6 through 12 circuits			
Mileage Bands			
• Over 0 to 8			
- Fixed	\$285.00	\$120.56	(T)
- Per mile	-	8.76	(T)
• Over 8 to 25			
- Fixed	285.00	153.47	(T)
- Per mile	-	12.06	(T)
• Over 25 to 50			
- Fixed	285.00	186.39	(T)
- Per mile	-	14.24	(T)
• Over 50			
- Fixed	285.00	186.39	(T)
- Per mile	-	14.24	(T)
c. 13 through 18 circuits			
Mileage Bands			
• Over 0 to 8			
- Fixed	285.00	117.38	(T)
- Per mile	-	8.53	(T)
• Over 8 to 25			
- Fixed	285.00	149.43	(T)
- Per mile	-	11.74	(T)
• Over 25 to 50			
- Fixed	285.00	181.49	(T)
- Per mile	-	13.86	(T)
• Over 50			
- Fixed	285.00	181.49	(T)
- Per mile	-	13.86	(T)

[1] Nonrecurring charges apply to Transport Mileage when installed without a Channel Termination.

Qwest Corporation
Private Line Transport Services
Catalog

State of North Dakota
 Effective: 04-19-2017

SECTION 6
 Page 42
 Release 2

6. RATES AND CHARGES

6.10 DS1 SERVICE

D.2. (Cont'd)

	NONRECURRING CHARGE	MONTHLY RATE	(T)
d. 19 circuits and above			
Mileage Bands[1]			
• Over 0 to 8			
- Fixed	\$285.00	\$114.21	(T)
- Per mile	-	8.30	(T)
• Over 8 to 25			
- Fixed	285.00	145.40	(T)
- Per mile	-	11.42	(T)
• Over 25 to 50			
- Fixed	285.00	176.58	(T)
- Per mile	-	13.49	(T)
• Over 50			
- Fixed	285.00	176.58	(T)
- Per mile	-	13.49	(T)
3. Optional Features and Functions			
a. Central Office Multiplexing, per arrangement[2]			
• DS1 to Voice/Data	150.00	270.00	(T)
• DS1 to DS0	150.00	270.00	(T)

[1] Nonrecurring charges apply to Transport Mileage when installed without a Channel Termination.

[2] Nonrecurring charges apply when multiplexing is not installed at the same time as a Channel Termination.

Qwest Corporation
Private Line Transport Services
Catalog

State of North Dakota
 Effective: 04-19-2017

SECTION 6
 Page 43
 Release 2

6. RATES AND CHARGES

6.10 DS1 SERVICE

D.3. (Cont'd)

	NONRECURRING CHARGE	MONTHLY RATE	(T)
b. Central Office Multiplexer to Multiplexer Connecting Arrangement, per arrangement			
• Between two multiplexers at the DS1 level	\$30.00	\$ 5.00	(T)
• Between two multiplexers at the DS1 level and optioned for B8ZS line code	30.00	5.00	(T)
c. Clear Channel Capability, per termination			
• B8ZS	-	-	(T)
d. Central Office 1.544 Mbit/s Connecting Channel, per channel			
• Between two different 1.544 Mbit/s not installed as one service	30.00	3.00	(T)
e. Automatic Loop Transfer, per arrangement[1]	20.00	45.00	(T)

[1] An additional Channel Termination Charge will apply whenever the spare line is provided as a leg to the customer premises.

Qwest Corporation
Private Line Transport Services
Catalog

State of North Dakota
Effective: 04-19-2017

SECTION 6
Page 44
Release 3

6. RATES AND CHARGES

6.10 DS1 SERVICE

D.3. (Cont'd)

	NONRECURRING CHARGE	MONTHLY RATE	(T)
f. Self Healing Alternate Route Protection (SHARP), per channel termination[1]			
• 1 through 5 circuits	\$600.00	\$68.45	(T)
• 6 through 12 circuits	600.00	65.03	
• 13 through 18 circuits	600.00	63.08	
• 19 circuits and above	600.00	61.18	(T)

[1] Nonrecurring charges apply when the SHARP is not installed at the same time as a Channel Termination.

Qwest Corporation
Private Line Transport Services
Catalog

State of North Dakota
 Effective: 04-19-2017

SECTION 6
 Page 45
 Release 2

6. RATES AND CHARGES

6.10 DS1 SERVICE (Cont'd)

E. Four-Year Contract

	NONRECURRING CHARGE	MONTHLY RATE	(T)
1. Channel Termination - Initial, per termination			
• 1 through 5 circuits	\$340.00	\$119.85	(T)
• 6 through 12 circuits	340.00	113.86	
• 13 through 18 circuits	340.00	110.86	
• 19 circuits and above	340.00	107.87	(T)
Channel Termination - Subsequent, per termination			
• 1 through 5 circuits	316.00	119.85	(T)
• 6 through 12 circuits	316.00	113.86	
• 13 through 18 circuits	316.00	110.86	
• 19 circuits and above	316.00	107.87	(T)
2. Transport Mileage[1]			
a. 1 through 5 circuits			
Mileage Bands			
• Over 0 to 8			
- Fixed	285.00	119.85	(T)
- Per mile	-	8.71	(T)
• Over 8 to 25			
- Fixed	285.00	152.58	(T)
- Per mile	-	11.99	(T)
• Over 25 to 50			
- Fixed	285.00	185.30	(T)
- Per mile	-	14.15	(T)
• Over 50			
- Fixed	285.00	185.30	(T)
- Per mile	-	14.15	(T)

[1] Nonrecurring charges apply to Transport Mileage when installed without a Channel Termination.

Qwest Corporation
Private Line Transport Services
Catalog

State of North Dakota
 Effective: 04-19-2017

SECTION 6
 Page 46
 Release 2

6. RATES AND CHARGES

6.10 DS1 SERVICE

E.2. (Cont'd)

	NONRECURRING CHARGE[1]	MONTHLY RATE	(T)
b. 6 through 12 circuits			
Mileage Bands			
• Over 0 to 8			
- Fixed	\$285.00	\$113.86	(T)
- Per mile	-	8.28	(T)
• Over 8 to 25			
- Fixed	285.00	144.95	(T)
- Per mile	-	11.39	(T)
• Over 25 to 50			
- Fixed	285.00	176.04	(T)
- Per mile	-	13.44	(T)
• Over 50			
- Fixed	285.00	176.04	(T)
- Per mile	-	13.44	(T)
c. 13 through 18 circuits			
Mileage Bands			
• Over 0 to 8			
- Fixed	285.00	110.86	(T)
- Per mile	-	8.06	(T)
• Over 8 to 25			
- Fixed	285.00	141.13	(T)
- Per mile	-	11.09	(T)
• Over 25 to 50			
- Fixed	285.00	171.40	(T)
- Per mile	-	13.09	(T)
• Over 50			
- Fixed	285.00	171.40	(T)
- Per mile	-	13.09	(T)

[1] Nonrecurring charges apply to Transport Mileage when installed without a Channel Termination.

Qwest Corporation
Private Line Transport Services
Catalog

State of North Dakota
 Effective: 04-19-2017

SECTION 6
 Page 47
 Release 2

6. RATES AND CHARGES

6.10 DS1 SERVICE

E.2. (Cont'd)

	NONRECURRING CHARGE	MONTHLY RATE	(T)
d. 19 circuits and above			
Mileage Bands[1]			
• Over 0 to 8			
- Fixed	\$285.00	\$107.87	(T)
- Per mile	-	7.84	(T)
• Over 8 to 25			
- Fixed	285.00	137.32	(T)
- Per mile	-	10.79	(T)
• Over 25 to 50			
- Fixed	285.00	166.77	(T)
- Per mile	-	12.74	(T)
• Over 50			
- Fixed	285.00	166.77	(T)
- Per mile	-	12.74	(T)
3. Optional Features and Functions			
a. Central Office Multiplexing, per arrangement[2]			
• DS1 to Voice/Data	150.00	255.00	(T)
• DS1 to DS0	150.00	255.00	(T)

[1] Nonrecurring charges apply to Transport Mileage when installed without a Channel Termination.

[2] Nonrecurring charges apply when multiplexing is not installed at the same time as a Channel Termination.

Qwest Corporation
Private Line Transport Services
Catalog

State of North Dakota
Effective: 04-19-2017

SECTION 6
Page 48
Release 2

6. RATES AND CHARGES

6.10 DS1 SERVICE

E.3. (Cont'd)

	NONRECURRING CHARGE	MONTHLY RATE	(T)
b. Central Office Multiplexer to Multiplexer Connecting Arrangement, per arrangement			
• Between two multiplexers at the DS1 level	\$30.00	\$ 5.00	(T)
• Between two multiplexers at the DS1 level and optioned for B8ZS line code	30.00	5.00	(T)
c. Clear Channel Capability, per termination			
• B8ZS	-	-	(T)
d. Central Office 1.544 Mbit/s Connecting Channel, per channel			
• Between two different 1.544 Mbit/s not installed as one service	30.00	3.00	(T)
e. Automatic Loop Transfer, per arrangement[1]	20.00	45.00	(T)

[1] An additional Channel Termination Charge will apply whenever the spare line is provided as a leg to the customer premises.

NOTICE
THE INFORMATION CONTAINED IN THIS DOCUMENT IS SUBJECT TO CHANGE.

Qwest Corporation
Private Line Transport Services
Catalog

State of North Dakota
Effective: 04-19-2017

SECTION 6
Page 49
Release 3

6. RATES AND CHARGES

6.10 DS1 SERVICE

E.3. (Cont'd)

	NONRECURRING CHARGE	MONTHLY RATE	(T)
f. Self Healing Alternate Route Protection (SHARP), per channel termination[1]			
• 1 through 5 circuits	\$600.00	\$66.40	(T)
• 6 through 12 circuits	600.00	63.08	
• 13 through 18 circuits	600.00	61.18	
• 19 circuits and above	600.00	59.35	(T)

[1] Nonrecurring charges apply when the SHARP is not installed at the same time as a Channel Termination.

Qwest Corporation
Private Line Transport Services
Catalog

State of North Dakota
 Effective: 04-19-2017

SECTION 6
 Page 50
 Release 2

6. RATES AND CHARGES

6.10 DS1 SERVICE (Cont'd)

F. Five-Year Contract

	NONRECURRING CHARGE	MONTHLY RATE	(T)
1. Channel Termination - Initial, per termination			
• 1 through 5 circuits	\$340.00	\$109.98	(T)
• 6 through 12 circuits	340.00	104.48	
• 13 through 18 circuits	340.00	101.73	
• 19 circuits and above	340.00	98.98	(T)
Channel Termination - Subsequent, per termination			
• 1 through 5 circuits	316.00	109.98	(T)
• 6 through 12 circuits	316.00	104.48	
• 13 through 18 circuits	316.00	101.73	
• 19 circuits and above	316.00	98.98	(T)
2. Transport Mileage[1]			
a. 1 through 5 circuits			
Mileage Bands			
• Over 0 to 8			
- Fixed	285.00	109.98	(T)
- Per mile	-	8.00	(T)
• Over 8 to 25			
- Fixed	285.00	140.01	(T)
- Per mile	-	11.00	(T)
• Over 25 to 50			
- Fixed	285.00	170.04	(T)
- Per mile	-	12.99	(T)
• Over 50			
- Fixed	285.00	170.04	(T)
- Per mile	-	12.99	(T)

[1] Nonrecurring charges apply to Transport Mileage when installed without a Channel Termination.

Qwest Corporation
Private Line Transport Services
Catalog

State of North Dakota
Effective: 04-19-2017

SECTION 6
Page 51
Release 2

6. RATES AND CHARGES

6.10 DS1 SERVICE

F.2. (Cont'd)

	NONRECURRING CHARGE[1]	MONTHLY RATE	(T)
b. 6 through 12 circuits			
Mileage Bands			
• Over 0 to 8			
- Fixed	\$285.00	\$104.48	(T)
- Per mile	-	7.60	(T)
• Over 8 to 25			
- Fixed	285.00	133.01	(T)
- Per mile	-	10.45	(T)
• Over 25 to 50			
- Fixed	285.00	161.54	(T)
- Per mile	-	12.34	(T)
• Over 50			
- Fixed	285.00	161.54	(T)
- Per mile	-	12.34	(T)
c. 13 through 18 circuits			
Mileage Bands			
• Over 0 to 8			
- Fixed	285.00	101.73	(T)
- Per mile	-	7.40	(T)
• Over 8 to 25			
- Fixed	285.00	129.51	(T)
- Per mile	-	10.17	(T)
• Over 25 to 50			
- Fixed	285.00	157.29	(T)
- Per mile	-	12.01	(T)
• Over 50			
- Fixed	285.00	157.29	(T)
- Per mile	-	12.01	(T)

[1] Nonrecurring charges apply to Transport Mileage when installed without a Channel Termination.

Qwest Corporation
Private Line Transport Services
Catalog

State of North Dakota
 Effective: 04-19-2017

SECTION 6
 Page 52
 Release 2

6. RATES AND CHARGES

6.10 DS1 SERVICE

F.2. (Cont'd)

	NONRECURRING CHARGE	MONTHLY RATE	(T)
d. 19 circuits and above			
Mileage Bands[1]			
• Over 0 to 8			
- Fixed	\$285.00	\$ 98.98	(T)
- Per mile	-	7.20	(T)
• Over 8 to 25			
- Fixed	285.00	126.01	(T)
- Per mile	-	9.90	(T)
• Over 25 to 50			
- Fixed	285.00	153.04	(T)
- Per mile	-	11.69	(T)
• Over 50			
- Fixed	285.00	153.04	(T)
- Per mile	-	11.69	(T)
3. Optional Features and Functions			
a. Central Office Multiplexing, per arrangement[2]			
• DS1 to Voice/Data	150.00	234.00	(T)
• DS1 to DS0	150.00	234.00	(T)

[1] Nonrecurring charges apply to Transport Mileage when installed without a Channel Termination.

[2] Nonrecurring charges apply when multiplexing is not installed at the same time as a Channel Termination.

Qwest Corporation
Private Line Transport Services
Catalog

State of North Dakota
 Effective: 04-19-2017

SECTION 6
 Page 53
 Release 2

6. RATES AND CHARGES

6.10 DS1 SERVICE

F.3. (Cont'd)

	NONRECURRING CHARGE	MONTHLY RATE	(T)
b. Central Office Multiplexer to Multiplexer Connecting Arrangement, per arrangement			
• Between two multiplexers at the DS1 level	\$30.00	\$ 5.00	(T)
• Between two multiplexers at the DS1 level and optioned for B8ZS line code	30.00	5.00	(T)
c. Clear Channel Capability, per termination			
• B8ZS	-	-	(T)
d. Central Office 1.544 Mbit/s Connecting Channel, per channel			
• Between two different 1.544 Mbit/s not installed as one service	30.00	3.00	(T)
e. Automatic Loop Transfer, per arrangement[1]	20.00	45.00	(T)

[1] An additional Channel Termination Charge will apply whenever the spare line is provided as a leg to the customer premises.

Qwest Corporation
Private Line Transport Services
Catalog

State of North Dakota
Effective: 04-19-2017

SECTION 6
Page 54
Release 3

6. RATES AND CHARGES

6.10 DS1 SERVICE

F.3. (Cont'd)

	NONRECURRING CHARGE	MONTHLY RATE	(T)
f. Self Healing Alternate Route Protection (SHARP), per channel termination[1]			
• 1 through 5 circuits	\$600.00	\$64.41	(T)
• 6 through 12 circuits	600.00	61.18	
• 13 through 18 circuits	600.00	59.35	
• 19 circuits and above	600.00	57.57	(T)

[1] Nonrecurring charges apply when the SHARP is not installed at the same time as a Channel Termination.

Qwest Corporation
Private Line Transport Services
Catalog

State of North Dakota
 Effective: 04-19-2017

SECTION 6
 Page 55
 Release 2

6. RATES AND CHARGES

6.10 DS1 SERVICE (Cont'd)

G. Six-Year Contract

	NONRECURRING CHARGE	MONTHLY RATE	(T)
1. Channel Termination - Initial, per termination			
• 1 through 5 circuits	\$340.00	\$109.28	(T)
• 6 through 12 circuits	340.00	103.81	
• 13 through 18 circuits	340.00	101.08	
• 19 circuits and above	340.00	98.35	(T)
Channel Termination - Subsequent, per termination			
• 1 through 5 circuits	316.00	109.28	(T)
• 6 through 12 circuits	316.00	103.81	
• 13 through 18 circuits	316.00	101.08	
• 19 circuits and above	316.00	98.35	(T)
2. Transport Mileage[1]			
a. 1 through 5 circuits			
Mileage Bands			
• Over 0 to 8			
- Fixed	285.00	109.28	(T)
- Per mile	-	7.94	(T)
• Over 8 to 25			
- Fixed	285.00	139.11	(T)
- Per mile	-	10.93	(T)
• Over 25 to 50			
- Fixed	285.00	168.95	(T)
- Per mile	-	12.90	(T)
• Over 50			
- Fixed	285.00	168.95	(T)
- Per mile	-	12.90	(T)

[1] Nonrecurring charges apply to Transport Mileage when installed without a Channel Termination.

Qwest Corporation
Private Line Transport Services
Catalog

State of North Dakota
Effective: 04-19-2017

SECTION 6
Page 56
Release 2

6. RATES AND CHARGES

6.10 DS1 SERVICE

G.2. (Cont'd)

	NONRECURRING CHARGE[1]	MONTHLY RATE	(T)
b. 6 through 12 circuits			
Mileage Bands			
• Over 0 to 8			
- Fixed	\$285.00	\$103.81	(T)
- Per mile	-	7.55	(T)
• Over 8 to 25			
- Fixed	285.00	132.16	(T)
- Per mile	-	10.38	(T)
• Over 25 to 50			
- Fixed	285.00	160.50	(T)
- Per mile	-	12.26	(T)
• Over 50			
- Fixed	285.00	160.50	(T)
- Per mile	-	12.26	(T)
c. 13 through 18 circuits			
Mileage Bands			
• Over 0 to 8			
- Fixed	285.00	101.08	(T)
- Per mile	-	7.35	(T)
• Over 8 to 25			
- Fixed	285.00	128.68	(T)
- Per mile	-	10.11	(T)
• Over 25 to 50			
- Fixed	285.00	156.28	(T)
- Per mile	-	11.94	(T)
• Over 50			
- Fixed	285.00	156.28	(T)
- Per mile	-	11.94	(T)

[1] Nonrecurring charges apply to Transport Mileage when installed without a Channel Termination.

Qwest Corporation
Private Line Transport Services
Catalog

State of North Dakota
 Effective: 04-19-2017

SECTION 6
 Page 57
 Release 2

6. RATES AND CHARGES

6.10 DS1 SERVICE

G.2. (Cont'd)

	NONRECURRING CHARGE	MONTHLY RATE	(T)
d. 19 circuits and above			
Mileage Bands[1]			
• Over 0 to 8			
- Fixed	\$285.00	\$ 98.35	(T)
- Per mile	-	7.15	(T)
• Over 8 to 25			
- Fixed	285.00	125.20	(T)
- Per mile	-	9.83	(T)
• Over 25 to 50			
- Fixed	285.00	152.06	(T)
- Per mile	-	11.61	(T)
• Over 50			
- Fixed	285.00	152.06	(T)
- Per mile	-	11.61	(T)
3. Optional Features and Functions			
a. Central Office Multiplexing, per arrangement[2]			
• DS1 to Voice/Data	150.00	232.50	(T)
• DS1 to DS0	150.00	232.50	(T)

[1] Nonrecurring charges apply to Transport Mileage when installed without a Channel Termination.

[2] Nonrecurring charges apply when multiplexing is not installed at the same time as a Channel Termination.

Qwest Corporation
Private Line Transport Services
Catalog

State of North Dakota
 Effective: 04-19-2017

SECTION 6
 Page 58
 Release 2

6. RATES AND CHARGES

6.10 DS1 SERVICE

G.3. (Cont'd)

	NONRECURRING CHARGE	MONTHLY RATE	(T)
b. Central Office Multiplexer to Multiplexer Connecting Arrangement, per arrangement			
• Between two multiplexers at the DS1 level	\$30.00	\$ 5.00	(T)
• Between two multiplexers at the DS1 level and optioned for B8ZS line code	30.00	5.00	(T)
c. Clear Channel Capability, per termination			
• B8ZS	-	-	(T)
d. Central Office 1.544 Mbit/s Connecting Channel, per channel			
• Between two different 1.544 Mbit/s not installed as one service	30.00	3.00	(T)
e. Automatic Loop Transfer, per arrangement[1]	20.00	45.00	(T)

[1] An additional Channel Termination Charge will apply whenever the spare line is provided as a leg to the customer premises.

Qwest Corporation
Private Line Transport Services
Catalog

State of North Dakota
Effective: 04-19-2017

SECTION 6
Page 59
Release 3

6. RATES AND CHARGES

6.10 DS1 SERVICE

G.3. (Cont'd)

	NONRECURRING CHARGE	MONTHLY RATE	(T)
f. Self Healing Alternate Route Protection (SHARP), per channel termination[1]			
• 1 through 5 circuits	\$600.00	\$62.47	(T)
• 6 through 12 circuits	600.00	59.35	
• 13 through 18 circuits	600.00	57.57	
• 19 circuits and above	600.00	55.84	(T)

[1] Nonrecurring charges apply when the SHARP is not installed at the same time as a Channel Termination.

Qwest Corporation
Private Line Transport Services
Catalog

State of North Dakota
 Effective: 04-19-2017

SECTION 6
 Page 60
 Release 2

6. RATES AND CHARGES

6.10 DS1 SERVICE (Cont'd)

H. Seven-Year Contract

	NONRECURRING CHARGE	MONTHLY RATE	(T)
1. Channel Termination - Initial, per termination			
• 1 through 5 circuits	\$340.00	\$108.57	(T)
• 6 through 12 circuits	340.00	103.14	
• 13 through 18 circuits	340.00	100.43	
• 19 circuits and above	340.00	97.71	(T)
Channel Termination - Subsequent, per termination			
• 1 through 5 circuits	316.00	108.57	(T)
• 6 through 12 circuits	316.00	103.14	
• 13 through 18 circuits	316.00	100.43	
• 19 circuits and above	316.00	97.71	(T)
2. Transport Mileage[1]			
a. 1 through 5 circuits			
Mileage Bands			
• Over 0 to 8			
- Fixed	285.00	108.57	(T)
- Per mile	-	7.89	(T)
• Over 8 to 25			
- Fixed	285.00	138.22	(T)
- Per mile	-	10.86	(T)
• Over 25 to 50			
- Fixed	285.00	167.86	(T)
- Per mile	-	12.82	(T)
• Over 50			
- Fixed	285.00	167.86	(T)
- Per mile	-	12.82	(T)

[1] Nonrecurring charges apply to Transport Mileage when installed without a Channel Termination.

Qwest Corporation
Private Line Transport Services
Catalog

State of North Dakota
Effective: 04-19-2017

SECTION 6
Page 61
Release 2

6. RATES AND CHARGES

6.10 DS1 SERVICE

H.2. (Cont'd)

	NONRECURRING CHARGE[1]	MONTHLY RATE	(T)
b. 6 through 12 circuits			
Mileage Bands			
• Over 0 to 8			
- Fixed	\$285.00	\$103.14	(T)
- Per mile	-	7.50	(T)
• Over 8 to 25			
- Fixed	285.00	131.30	(T)
- Per mile	-	10.31	(T)
• Over 25 to 50			
- Fixed	285.00	159.47	(T)
- Per mile	-	12.18	(T)
• Over 50			
- Fixed	285.00	159.47	(T)
- Per mile	-	12.18	(T)
c. 13 through 18 circuits			
Mileage Bands			
• Over 0 to 8			
- Fixed	285.00	100.43	(T)
- Per mile	-	7.30	(T)
• Over 8 to 25			
- Fixed	285.00	127.85	(T)
- Per mile	-	10.04	(T)
• Over 25 to 50			
- Fixed	285.00	155.27	(T)
- Per mile	-	11.86	(T)
• Over 50			
- Fixed	285.00	155.27	(T)
- Per mile	-	11.86	(T)

[1] Nonrecurring charges apply to Transport Mileage when installed without a Channel Termination.

Qwest Corporation
Private Line Transport Services
Catalog

State of North Dakota
 Effective: 04-19-2017

SECTION 6
 Page 62
 Release 2

6. RATES AND CHARGES

6.10 DS1 SERVICE

H.2. (Cont'd)

	NONRECURRING CHARGE	MONTHLY RATE	(T)
d. 19 circuits and above			
Mileage Bands[1]			
• Over 0 to 8			
- Fixed	\$285.00	\$ 97.71	(T)
- Per mile	-	7.10	(T)
• Over 8 to 25			
- Fixed	285.00	124.39	(T)
- Per mile	-	9.77	(T)
• Over 25 to 50			
- Fixed	285.00	151.07	(T)
- Per mile	-	11.54	(T)
• Over 50			
- Fixed	285.00	151.07	(T)
- Per mile	-	11.54	(T)
3. Optional Features and Functions			
a. Central Office Multiplexing, per arrangement[2]			
• DS1 to Voice/Data	150.00	231.00	(T)
• DS1 to DS0	150.00	231.00	(T)

[1] Nonrecurring charges apply to Transport Mileage when installed without a Channel Termination.

[2] Nonrecurring charges apply when multiplexing is not installed at the same time as a Channel Termination.

Qwest Corporation
Private Line Transport Services
Catalog

State of North Dakota
 Effective: 04-19-2017

SECTION 6
 Page 63
 Release 2

6. RATES AND CHARGES

6.10 DS1 SERVICE

H.3. (Cont'd)

	NONRECURRING CHARGE	MONTHLY RATE	(T)
b. Central Office Multiplexer to Multiplexer Connecting Arrangement, per arrangement			
• Between two multiplexers at the DS1 level	\$30.00	\$ 5.00	(T)
• Between two multiplexers at the DS1 level and optioned for B8ZS line code	30.00	5.00	(T)
c. Clear Channel Capability, per termination			
• B8ZS	-	-	(T)
d. Central Office 1.544 Mbit/s Connecting Channel, per channel			
• Between two different 1.544 Mbit/s not installed as one service	30.00	3.00	(T)
e. Automatic Loop Transfer, per arrangement[1]	20.00	45.00	(T)

[1] An additional Channel Termination Charge will apply whenever the spare line is provided as a leg to the customer premises.

Qwest Corporation
Private Line Transport Services
Catalog

State of North Dakota
Effective: 04-19-2017

SECTION 6
Page 64
Release 3

6. RATES AND CHARGES

6.10 DS1 SERVICE

H.3. (Cont'd)

	NONRECURRING CHARGE	MONTHLY RATE	(T)
f. Self Healing Alternate Route Protection (SHARP), per channel termination[1]			
• 1 through 5 circuits	\$600.00	\$60.60	(T)
• 6 through 12 circuits	600.00	57.57	
• 13 through 18 circuits	600.00	55.84	
• 19 circuits and above	600.00	54.17	(T)

[1] Nonrecurring charges apply when the SHARP is not installed at the same time as a Channel Termination.

Qwest Corporation
Private Line Transport Services
Catalog

State of North Dakota
 Effective: 04-19-2017

SECTION 6
 Page 65
 Release 2

6. RATES AND CHARGES

6.10 DS1 SERVICE (Cont'd)

I. Eight-Year Contract

	NONRECURRING CHARGE	MONTHLY RATE	(T)
1. Channel Termination - Initial, per termination			
• 1 through 5 circuits	\$340.00	\$107.87	(T)
• 6 through 12 circuits	340.00	102.47	
• 13 through 18 circuits	340.00	99.78	
• 19 circuits and above	340.00	97.08	(T)
Channel Termination - Subsequent, per termination			
• 1 through 5 circuits	316.00	107.87	(T)
• 6 through 12 circuits	316.00	102.47	
• 13 through 18 circuits	316.00	99.78	
• 19 circuits and above	316.00	97.08	(T)
2. Transport Mileage[1]			
a. 1 through 5 circuits			
Mileage Bands			
• Over 0 to 8			
- Fixed	285.00	107.87	(T)
- Per mile	-	7.84	(T)
• Over 8 to 25			
- Fixed	285.00	137.32	(T)
- Per mile	-	10.79	(T)
• Over 25 to 50			
- Fixed	285.00	166.77	(T)
- Per mile	-	12.74	(T)
• Over 50			
- Fixed	285.00	166.77	(T)
- Per mile	-	12.74	(T)

[1] Nonrecurring charges apply to Transport Mileage when installed without a Channel Termination.

Qwest Corporation
Private Line Transport Services
Catalog

State of North Dakota
 Effective: 04-19-2017

SECTION 6
 Page 66
 Release 2

6. RATES AND CHARGES

6.10 DS1 SERVICE

I.2. (Cont'd)

	NONRECURRING CHARGE[1]	MONTHLY RATE	(T)
b. 6 through 12 circuits			
Mileage Bands			
• Over 0 to 8			
- Fixed	\$285.00	\$102.47	(T)
- Per mile	-	7.45	(T)
• Over 8 to 25			
- Fixed	285.00	130.45	(T)
- Per mile	-	10.25	(T)
• Over 25 to 50			
- Fixed	285.00	158.43	(T)
- Per mile	-	12.10	(T)
• Over 50			
- Fixed	285.00	158.43	(T)
- Per mile	-	12.10	(T)
c. 13 through 18 circuits			
Mileage Bands			
• Over 0 to 8			
- Fixed	285.00	99.78	(T)
- Per mile	-	7.25	(T)
• Over 8 to 25			
- Fixed	285.00	127.02	(T)
- Per mile	-	9.98	(T)
• Over 25 to 50			
- Fixed	285.00	154.26	(T)
- Per mile	-	11.78	(T)
• Over 50			
- Fixed	285.00	154.26	(T)
- Per mile	-	11.78	(T)

[1] Nonrecurring charges apply to Transport Mileage when installed without a Channel Termination.

Qwest Corporation
Private Line Transport Services
Catalog

State of North Dakota
 Effective: 04-19-2017

SECTION 6
 Page 67
 Release 2

6. RATES AND CHARGES

6.10 DS1 SERVICE

I.2. (Cont'd)

	NONRECURRING CHARGE	MONTHLY RATE	(T)
d. 19 circuits and above			
Mileage Bands[1]			
• Over 0 to 8			
- Fixed	\$285.00	\$ 97.08	(T)
- Per mile	-	7.06	(T)
• Over 8 to 25			
- Fixed	285.00	123.59	(T)
- Per mile	-	9.71	(T)
• Over 25 to 50			
- Fixed	285.00	150.09	(T)
- Per mile	-	11.46	(T)
• Over 50			
- Fixed	285.00	150.09	(T)
- Per mile	-	11.46	(T)
3. Optional Features and Functions			
a. Central Office Multiplexing, per arrangement[2]			
• DS1 to Voice/Data	150.00	229.50	(T)
• DS1 to DS0	150.00	229.50	(T)

[1] Nonrecurring charges apply to Transport Mileage when installed without a Channel Termination.

[2] Nonrecurring charges apply when multiplexing is not installed at the same time as a Channel Termination.

Qwest Corporation
Private Line Transport Services
Catalog

State of North Dakota
 Effective: 04-19-2017

SECTION 6
 Page 68
 Release 2

6. RATES AND CHARGES

6.10 DS1 SERVICE

I.3. (Cont'd)

	NONRECURRING CHARGE	MONTHLY RATE	(T)
b. Central Office Multiplexer to Multiplexer Connecting Arrangement, per arrangement			
• Between two multiplexers at the DS1 level	\$30.00	\$ 5.00	(T)
• Between two multiplexers at the DS1 level and optioned for B8ZS line code	30.00	5.00	(T)
c. Clear Channel Capability, per termination			
• B8ZS	-	-	(T)
d. Central Office 1.544 Mbit/s Connecting Channel, per channel			
• Between two different 1.544 Mbit/s not installed as one service	30.00	3.00	(T)
e. Automatic Loop Transfer, per arrangement[1]	20.00	45.00	(T)

[1] An additional Channel Termination Charge will apply whenever the spare line is provided as a leg to the customer premises.

Qwest Corporation
Private Line Transport Services
Catalog

State of North Dakota
Effective: 04-19-2017

SECTION 6
Page 69
Release 3

6. RATES AND CHARGES

6.10 DS1 SERVICE

I.3. (Cont'd)

	NONRECURRING CHARGE	MONTHLY RATE	(T)
f. Self Healing Alternate Route Protection (SHARP), per channel termination[1]			
• 1 through 5 circuits	\$600.00	\$58.78	(T)
• 6 through 12 circuits	600.00	55.84	
• 13 through 18 circuits	600.00	54.17	
• 19 circuits and above	600.00	52.54	(T)

[1] Nonrecurring charges apply when the SHARP is not installed at the same time as a Channel Termination.

Qwest Corporation
Private Line Transport Services
Catalog

State of North Dakota
 Effective: 04-19-2017

SECTION 6
 Page 70
 Release 2

6. RATES AND CHARGES

6.10 DS1 SERVICE (Cont'd)

J. Nine-Year Contract

	NONRECURRING CHARGE	MONTHLY RATE	(T)
1. Channel Termination - Initial, per termination			
• 1 through 5 circuits	\$340.00	\$107.16	(T)
• 6 through 12 circuits	340.00	101.80	
• 13 through 18 circuits	340.00	99.12	
• 19 circuits and above	340.00	96.44	(T)
Channel Termination - Subsequent, per termination			
• 1 through 5 circuits	316.00	107.16	(T)
• 6 through 12 circuits	316.00	101.80	
• 13 through 18 circuits	316.00	99.12	
• 19 circuits and above	316.00	96.44	(T)
2. Transport Mileage[1]			
a. 1 through 5 circuits			
Mileage Bands			
• Over 0 to 8			
- Fixed	285.00	107.16	(T)
- Per mile	-	7.79	(T)
• Over 8 to 25			
- Fixed	285.00	136.42	(T)
- Per mile	-	10.72	(T)
• Over 25 to 50			
- Fixed	285.00	165.68	(T)
- Per mile	-	12.65	(T)
• Over 50			
- Fixed	285.00	165.68	(T)
- Per mile	-	12.65	(T)

[1] Nonrecurring charges apply to Transport Mileage when installed without a Channel Termination.

Qwest Corporation
Private Line Transport Services
Catalog

State of North Dakota
 Effective: 04-19-2017

SECTION 6
 Page 71
 Release 2

6. RATES AND CHARGES

6.10 DS1 SERVICE

J.2. (Cont'd)

	NONRECURRING CHARGE[1]	MONTHLY RATE	(T)
b. 6 through 12 circuits			
Mileage Bands			
• Over 0 to 8			
- Fixed	\$285.00	\$101.80	(T)
- Per mile	-	7.40	(T)
• Over 8 to 25			
- Fixed	285.00	129.60	(T)
- Per mile	-	10.18	(T)
• Over 25 to 50			
- Fixed	285.00	157.40	(T)
- Per mile	-	12.02	(T)
• Over 50			
- Fixed	285.00	157.40	(T)
- Per mile	-	12.02	(T)
c. 13 through 18 circuits			
Mileage Bands			
• Over 0 to 8			
- Fixed	285.00	99.12	(T)
- Per mile	-	7.21	(T)
• Over 8 to 25			
- Fixed	285.00	126.19	(T)
- Per mile	-	9.91	(T)
• Over 25 to 50			
- Fixed	285.00	153.25	(T)
- Per mile	-	11.70	(T)
• Over 50			
- Fixed	285.00	153.25	(T)
- Per mile	-	11.70	(T)

[1] Nonrecurring charges apply to Transport Mileage when installed without a Channel Termination.

Qwest Corporation
Private Line Transport Services
Catalog

State of North Dakota
 Effective: 04-19-2017

SECTION 6
 Page 72
 Release 2

6. RATES AND CHARGES

6.10 DS1 SERVICE

J.2. (Cont'd)

	NONRECURRING CHARGE	MONTHLY RATE	(T)
d. 19 circuits and above			
Mileage Bands[1]			
• Over 0 to 8			
- Fixed	\$285.00	\$ 96.44	(T)
- Per mile	-	7.01	(T)
• Over 8 to 25			
- Fixed	285.00	122.78	(T)
- Per mile	-	9.64	(T)
• Over 25 to 50			
- Fixed	285.00	149.11	(T)
- Per mile	-	11.39	(T)
• Over 50			
- Fixed	285.00	149.11	(T)
- Per mile	-	11.39	(T)
3. Optional Features and Functions			
a. Central Office Multiplexing, per arrangement[2]			
• DS1 to Voice/Data	150.00	228.00	(T)
• DS1 to DS0	150.00	228.00	(T)

[1] Nonrecurring charges apply to Transport Mileage when installed without a Channel Termination.

[2] Nonrecurring charges apply when multiplexing is not installed at the same time as a Channel Termination.

Qwest Corporation
Private Line Transport Services
Catalog

State of North Dakota
 Effective: 04-19-2017

SECTION 6
 Page 73
 Release 2

6. RATES AND CHARGES

6.10 DS1 SERVICE

J.3. (Cont'd)

	NONRECURRING CHARGE	MONTHLY RATE	(T)
b. Central Office Multiplexer to Multiplexer Connecting Arrangement, per arrangement			
• Between two multiplexers at the DS1 level	\$30.00	\$ 5.00	(T)
• Between two multiplexers at the DS1 level and optioned for B8ZS line code	30.00	5.00	(T)
c. Clear Channel Capability, per termination			
• B8ZS	-	-	(T)
d. Central Office 1.544 Mbit/s Connecting Channel, per channel			
• Between two different 1.544 Mbit/s not installed as one service	30.00	3.00	(T)
e. Automatic Loop Transfer, per arrangement[1]	20.00	45.00	(T)

[1] An additional Channel Termination Charge will apply whenever the spare line is provided as a leg to the customer premises.

Qwest Corporation
Private Line Transport Services
Catalog

State of North Dakota
Effective: 04-19-2017

SECTION 6
Page 74
Release 3

6. RATES AND CHARGES

6.10 DS1 SERVICE

J.3. (Cont'd)

	NONRECURRING CHARGE	MONTHLY RATE	(T)
f. Self Healing Alternate Route Protection (SHARP), per channel termination[1]			
• 1 through 5 circuits	\$600.00	\$57.02	(T)
• 6 through 12 circuits	600.00	54.17	
• 13 through 18 circuits	600.00	52.54	
• 19 circuits and above	600.00	50.97	(T)

[1] Nonrecurring charges apply when the SHARP is not installed at the same time as a Channel Termination.

Qwest Corporation
Private Line Transport Services
Catalog

State of North Dakota
 Effective: 04-19-2017

SECTION 6
 Page 75
 Release 2

6. RATES AND CHARGES

6.10 DS1 SERVICE (Cont'd)

K. Ten-Year Contract

	NONRECURRING CHARGE	MONTHLY RATE	(T)
1. Channel Termination - Initial, per termination			
• 1 through 5 circuits	\$340.00	\$105.75	(T)
• 6 through 12 circuits	340.00	100.46	
• 13 through 18 circuits	340.00	97.82	
• 19 circuits and above	340.00	95.18	(T)
Channel Termination - Subsequent, per termination			
• 1 through 5 circuits	316.00	105.75	(T)
• 6 through 12 circuits	316.00	100.46	
• 13 through 18 circuits	316.00	97.82	
• 19 circuits and above	316.00	95.18	(T)
2. Transport Mileage[1]			
a. 1 through 5 circuits			
Mileage Bands			
• Over 0 to 8			
- Fixed	285.00	105.75	(T)
- Per mile	-	7.69	(T)
• Over 8 to 25			
- Fixed	285.00	134.63	(T)
- Per mile	-	10.58	(T)
• Over 25 to 50			
- Fixed	285.00	163.50	(T)
- Per mile	-	12.49	(T)
• Over 50			
- Fixed	285.00	163.50	(T)
- Per mile	-	12.49	(T)

[1] Nonrecurring charges apply to Transport Mileage when installed without a Channel Termination.

Qwest Corporation
Private Line Transport Services
Catalog

State of North Dakota
Effective: 04-19-2017

SECTION 6
Page 76
Release 2

6. RATES AND CHARGES

6.10 DS1 SERVICE

K.2. (Cont'd)

	NONRECURRING CHARGE[1]	MONTHLY RATE	(T)
b. 6 through 12 circuits			
Mileage Bands			
• Over 0 to 8			
- Fixed	\$285.00	\$100.46	(T)
- Per mile	-	7.30	(T)
• Over 8 to 25			
- Fixed	285.00	127.89	(T)
- Per mile	-	10.05	(T)
• Over 25 to 50			
- Fixed	285.00	155.33	(T)
- Per mile	-	11.86	(T)
• Over 50			
- Fixed	285.00	155.33	(T)
- Per mile	-	11.86	(T)
c. 13 through 18 circuits			
Mileage Bands			
• Over 0 to 8			
- Fixed	285.00	97.82	(T)
- Per mile	-	7.11	(T)
• Over 8 to 25			
- Fixed	285.00	124.53	(T)
- Per mile	-	9.78	(T)
• Over 25 to 50			
- Fixed	285.00	151.24	(T)
- Per mile	-	11.55	(T)
• Over 50			
- Fixed	285.00	151.24	(T)
- Per mile	-	11.55	(T)

[1] Nonrecurring charges apply to Transport Mileage when installed without a Channel Termination.

Qwest Corporation
Private Line Transport Services
Catalog

State of North Dakota
 Effective: 04-19-2017

SECTION 6
 Page 77
 Release 2

6. RATES AND CHARGES

6.10 DS1 SERVICE

K.2. (Cont'd)

	NONRECURRING CHARGE	MONTHLY RATE	(T)
d. 19 circuits and above			
Mileage Bands[1]			
• Over 0 to 8			
- Fixed	\$285.00	\$ 95.18	(T)
- Per mile	-	6.92	(T)
• Over 8 to 25			
- Fixed	285.00	121.16	(T)
- Per mile	-	9.52	(T)
• Over 25 to 50			
- Fixed	285.00	147.15	(T)
- Per mile	-	11.24	(T)
• Over 50			
- Fixed	285.00	147.15	(T)
- Per mile	-	11.24	(T)
3. Optional Features and Functions			
a. Central Office Multiplexing, per arrangement[2]			
• DS1 to Voice/Data	150.00	225.00	(T)
• DS1 to DS0	150.00	225.00	(T)

[1] Nonrecurring charges apply to Transport Mileage when installed without a Channel Termination.

[2] Nonrecurring charges apply when multiplexing is not installed at the same time as a Channel Termination.

Qwest Corporation
Private Line Transport Services
Catalog

State of North Dakota
 Effective: 04-19-2017

SECTION 6
 Page 78
 Release 2

6. RATES AND CHARGES

6.10 DS1 SERVICE

K.3. (Cont'd)

	NONRECURRING CHARGE	MONTHLY RATE	(T)
b. Central Office Multiplexer to Multiplexer Connecting Arrangement, per arrangement			
• Between two multiplexers at the DS1 level	\$30.00	\$ 5.00	(T)
• Between two multiplexers at the DS1 level and optioned for B8ZS line code	30.00	5.00	(T)
c. Clear Channel Capability, per termination			
• B8ZS	-	-	(T)
d. Central Office 1.544 Mbit/s Connecting Channel, per channel			
• Between two different 1.544 Mbit/s not installed as one service	30.00	3.00	(T)
e. Automatic Loop Transfer, per arrangement[1]	20.00	45.00	(T)

[1] An additional Channel Termination Charge will apply whenever the spare line is provided as a leg to the customer premises.

Qwest Corporation
Private Line Transport Services
Catalog

State of North Dakota
Effective: 04-19-2017

SECTION 6
Page 79
Release 3

6. RATES AND CHARGES

6.10 DS1 SERVICE

K.3. (Cont'd)

	NONRECURRING CHARGE	MONTHLY RATE	(T)
f. Self Healing Alternate Route Protection (SHARP), per channel termination[1]			
• 1 through 5 circuits	\$600.00	\$55.31	(T)
• 6 through 12 circuits	600.00	52.54	
• 13 through 18 circuits	600.00	50.97	
• 19 circuits and above	600.00	49.44	(T)

[1] Nonrecurring charges apply when the SHARP is not installed at the same time as a Channel Termination.

Qwest Corporation
Private Line Transport Services
Catalog

State of North Dakota
 Effective: 04-19-2017

SECTION 6
 Page 80
 Release 2

6. RATES AND CHARGES

6.11 DS3 SERVICE

Customers are required to sign a service agreement for one-year through ten-year service periods.

A. Month-to-Month

	NONRECURRING CHARGE	MONTHLY RATE	
1. Channel Termination, per termination			(T)
a. Electrical Interface			
• Capacity of 1	\$545.00	\$1,282.50	(T)
• Capacity of 2	-	2,090.00	
- Per DS3	545.00	179.90	
• Capacity of 3	-	2,384.50	
- Per DS3	545.00	143.45	
• Capacity of 6	-	3,709.75	
- Per DS3	545.00	90.25	
• Capacity of 9	-	5,386.50	
- Per DS3	545.00	87.40	
• Capacity of 12	-	7,110.75	
- Per DS3	545.00	87.40	
• Capacity of 24	-	13,532.75	
- Per DS3	545.00	87.40	
• Capacity of 36	-	17,712.75	
- Per DS3	545.00	104.50	(T)

Qwest Corporation
Private Line Transport Services
Catalog

State of North Dakota
 Effective: 04-19-2017

SECTION 6
 Page 81
 Release 2

6. RATES AND CHARGES

6.11 DS3 SERVICE

A. Month-to-Month (Cont'd)

	NONRECURRING CHARGE	MONTHLY RATE	
2. Central Office Connecting Channel			(T)
• Between two different DS3 services installed as two separate services	\$ 25.00	\$ 9.50	(T)
3. Transport Mileage[1]			
Mileage Bands			
• Over 0 to 8			
- Fixed	605.00	590.90	(T)
- Per mile	-	51.26	(T)
• Over 8 to 25			
- Fixed	605.00	593.75	(T)
- Per mile	-	35.15	(T)
• Over 25 to 50			
- Fixed	605.00	598.50	(T)
- Per mile	-	51.11	(T)
• Over 50			
- Fixed	605.00	619.40	(T)
- Per mile	-	57.92	(T)

[1] Nonrecurring charges apply to Transport Mileage when installed without a Channel Termination. When service involves more than one Exchange Telephone Company, one half the nonrecurring charge applies.

Qwest Corporation
Private Line Transport Services
Catalog

State of North Dakota
Effective: 04-19-2017

SECTION 6
Page 82
Release 3

6. RATES AND CHARGES

6.11 DS3 SERVICE

A. Month-to-Month (Cont'd)

	NONRECURRING CHARGE	MONTHLY RATE	(T)
4. Optional Features and Functions			
a. Central Office Multiplexing[1]	\$355.00	\$357.20	(T)
b. Self Healing Alternate Route Protection (SHARP)[2]			
• Per DS3 Channel Termination	600.00	285.00	(T)

[1] Nonrecurring charges apply when multiplexing is not installed at the same time as a Channel Termination.

[2] Nonrecurring charges apply when the SHARP is not installed at the same time as a Channel Termination.

NOTICE
THE INFORMATION CONTAINED IN THIS DOCUMENT IS SUBJECT TO CHANGE.

Qwest Corporation
Private Line Transport Services
Catalog

State of North Dakota
 Effective: 04-19-2017

SECTION 6
 Page 83
 Release 2

6. RATES AND CHARGES

6.11 DS3 SERVICE (Cont'd)

B. One-Year Contract

	NONRECURRING CHARGE	MONTHLY RATE	
1. Channel Termination, per termination			(T)
a. Electrical Interface			
• Capacity of 1	\$545.00	\$ 1,244.03	(T)
• Capacity of 2	-	2,027.30	
- Per DS3	545.00	167.71	
• Capacity of 3	-	2,312.97	
- Per DS3	545.00	139.15	
• Capacity of 6	-	3,598.46	
- Per DS3	545.00	87.54	
• Capacity of 9	-	5,224.91	
- Per DS3	545.00	84.78	
• Capacity of 12	-	6,897.43	
- Per DS3	545.00	84.78	
• Capacity of 24	-	13,126.77	
- Per DS3	545.00	84.78	
• Capacity of 36	-	17,181.37	
- Per DS3	545.00	101.37	(T)

**Qwest Corporation
Catalog
Private Line Transport Services**

State of North Dakota
Effective: 04-19-2017

SECTION 6
Page 84
Release 2

6. RATES AND CHARGES

6.11 DS3 SERVICE

B. One-Year Contract (Cont'd)

	NONRECURRING CHARGE	MONTHLY RATE	(T)
2. Central Office Connecting Channel			
• Between two different DS3 services installed as two separate services	\$ 25.00	\$ 9.50	(T)
3. Transport Mileage[1]			
Mileage Bands			
• Over 0 to 8			
- Fixed	605.00	573.17	(T)
- Per mile	-	49.89	(T)
• Over 8 to 25			
- Fixed	605.00	575.94	(T)
- Per mile	-	34.10	(T)
• Over 25 to 50			
- Fixed	605.00	580.55	(T)
- Per mile	-	49.74	(T)
• Over 50			
- Fixed	605.00	600.82	(T)
- Per mile	-	56.37	(T)

[1] Nonrecurring charges apply to Transport Mileage when installed without a Channel Termination. When service involves more than one Exchange Telephone Company, one half the nonrecurring charge applies.

Qwest Corporation
Private Line Transport Services
Catalog

State of North Dakota
Effective: 04-19-2017

SECTION 6
Page 85
Release 3

6. RATES AND CHARGES

6.11 DS3 SERVICE

B. One-Year Contract (Cont'd)

	NONRECURRING CHARGE	MONTHLY RATE	(T)
4. Optional Features and Functions			
a. Central Office Multiplexing[1]	\$355.00	\$346.75	(T)
b. Self Healing Alternate Route Protection (SHARP)[2]			
• Per DS3 Channel Termination	600.00	276.45	(T)

[1] Nonrecurring charges apply when multiplexing is not installed at the same time as a Channel Termination.

[2] Nonrecurring charges apply when the SHARP is not installed at the same time as a Channel Termination.

NOTICE
THE INFORMATION CONTAINED IN THIS DOCUMENT IS SUBJECT TO CHANGE.

Qwest Corporation
Private Line Transport Services
Catalog

State of North Dakota
 Effective: 04-19-2017

SECTION 6
 Page 86
 Release 2

6. RATES AND CHARGES

6.11 DS3 SERVICE (Cont'd)

C. Two-Year Contract

	NONRECURRING CHARGE	MONTHLY RATE	(T)
1. Channel Termination, per termination			
a. Electrical Interface			
• Capacity of 1	\$545.00	\$ 1,205.55	(T)
• Capacity of 2	-	1,964.60	
- Per DS3	545.00	162.53	
• Capacity of 3	-	2,241.43	
- Per DS3	545.00	134.84	
• Capacity of 6	-	3,487.17	
- Per DS3	545.00	84.84	
• Capacity of 9	-	5,063.31	
- Per DS3	545.00	82.16	
• Capacity of 12	-	6,684.11	
- Per DS3	545.00	82.16	
• Capacity of 24	-	12,720.79	
- Per DS3	545.00	82.16	
• Capacity of 36	-	16,649.99	
- Per DS3	545.00	98.23	(T)

Qwest Corporation
Private Line Transport Services
Catalog

State of North Dakota
 Effective: 04-19-2017

SECTION 6
 Page 87
 Release 2

6. RATES AND CHARGES

6.11 DS3 SERVICE

C. Two-Year Contract (Cont'd)

	NONRECURRING CHARGE	MONTHLY RATE	(T)
2. Central Office Connecting Channel			
• Between two different DS3 services installed as two separate services	\$ 25.00	\$ 9.50	(T)
3. Transport Mileage[1]			
Mileage Bands			
• Over 0 to 8			
- Fixed	605.00	555.45	(T)
- Per mile	-	48.18	(T)
• Over 8 to 25			
- Fixed	605.00	558.13	(T)
- Per mile	-	33.04	(T)
• Over 25 to 50			
- Fixed	605.00	562.59	(T)
- Per mile	-	48.04	(T)
• Over 50			
- Fixed	605.00	582.24	(T)
- Per mile	-	54.44	(T)

[1] Nonrecurring charges apply to Transport Mileage when installed without a Channel Termination. When service involves more than one Exchange Telephone Company, one half the nonrecurring charge applies.

NOTICE
 THE INFORMATION CONTAINED IN THIS DOCUMENT IS SUBJECT TO CHANGE.

Qwest Corporation
Private Line Transport Services
Catalog

State of North Dakota
Effective: 04-19-2017

SECTION 6
Page 88
Release 3

6. RATES AND CHARGES

6.11 DS3 SERVICE

C. Two-Year Contract (Cont'd)

	NONRECURRING CHARGE	MONTHLY RATE	(T)
4. Optional Features and Functions			
a. Central Office Multiplexing[1]	\$355.00	\$335.35	(T)
b. Self Healing Alternate Route Protection (SHARP)[2]			
• Per DS3 Channel Termination	600.00	268.16	(T)

[1] Nonrecurring charges apply when multiplexing is not installed at the same time as a Channel Termination.

[2] Nonrecurring charges apply when the SHARP is not installed at the same time as a Channel Termination.

NOTICE
THE INFORMATION CONTAINED IN THIS DOCUMENT IS SUBJECT TO CHANGE.

Qwest Corporation
Private Line Transport Services
Catalog

State of North Dakota
 Effective: 04-19-2017

SECTION 6
 Page 89
 Release 2

6. RATES AND CHARGES

6.11 DS3 SERVICE (Cont'd)

D. Three-Year Contract

	NONRECURRING CHARGE	MONTHLY RATE	
1. Channel Termination, per termination			(T)
a. Electrical Interface			
• Capacity of 1	\$545.00	\$ 1,154.25	(T)
• Capacity of 2	-	1,881.00	
- Per DS3	545.00	155.61	
• Capacity of 3	-	2,146.05	
- Per DS3	545.00	129.11	
• Capacity of 6	-	3,338.78	
- Per DS3	545.00	81.23	
• Capacity of 9	-	4,847.85	
- Per DS3	545.00	78.66	
• Capacity of 12	-	6,399.68	
- Per DS3	545.00	78.66	
• Capacity of 24	-	12,179.48	
- Per DS3	545.00	78.66	
• Capacity of 36	-	15,941.48	
- Per DS3	545.00	94.05	(T)

Qwest Corporation
Private Line Transport Services
Catalog

State of North Dakota
 Effective: 04-19-2017

SECTION 6
 Page 90
 Release 2

6. RATES AND CHARGES

6.11 DS3 SERVICE

D. Three-Year Contract (Cont'd)

	NONRECURRING CHARGE	MONTHLY RATE	(T)
2. Central Office Connecting Channel			
• Between two different DS3 services installed as two separate services	\$ 25.00	\$ 9.50	(T)
3. Transport Mileage[1]			
Mileage Bands			
• Over 0 to 8			
- Fixed	605.00	531.81	(T)
- Per mile	-	46.13	(T)
• Over 8 to 25			
- Fixed	605.00	534.38	(T)
- Per mile	-	31.46	(T)
• Over 25 to 50			
- Fixed	605.00	538.65	(T)
- Per mile	-	45.99	(T)
• Over 50			
- Fixed	605.00	557.46	(T)
- Per mile	-	52.12	(T)

[1] Nonrecurring charges apply to Transport Mileage when installed without a Channel Termination. When service involves more than one Exchange Telephone Company, one half the nonrecurring charge applies.

Qwest Corporation
Private Line Transport Services
Catalog

State of North Dakota
Effective: 04-19-2017

SECTION 6
Page 91
Release 3

6. RATES AND CHARGES

6.11 DS3 SERVICE

D. Three-Year Contract (Cont'd)

	NONRECURRING CHARGE	MONTHLY RATE	(T)
4. Optional Features and Functions			
a. Central Office Multiplexing[1]	\$355.00	\$321.10	(T)
b. Self Healing Alternate Route Protection (SHARP)[2]			
• Per DS3 Channel Termination	600.00	260.11	(T)

[1] Nonrecurring charges apply when multiplexing is not installed at the same time as a Channel Termination.

[2] Nonrecurring charges apply when the SHARP is not installed at the same time as a Channel Termination.

NOTICE
THE INFORMATION CONTAINED IN THIS DOCUMENT IS SUBJECT TO CHANGE.

Qwest Corporation
Private Line Transport Services
Catalog

State of North Dakota
 Effective: 04-19-2017

SECTION 6
 Page 92
 Release 2

6. RATES AND CHARGES

6.11 DS3 SERVICE (Cont'd)

E. Four-Year Contract

	NONRECURRING CHARGE	MONTHLY RATE	(T)
1. Channel Termination, per termination			
a. Electrical Interface			
• Capacity of 1	\$545.00	\$ 1,090.13	(T)
• Capacity of 2	-	1,776.50	
- Per DS3	545.00	146.97	
• Capacity of 3	-	2,026.83	
- Per DS3	545.00	121.93	
• Capacity of 6	-	3,153.29	
- Per DS3	545.00	76.71	
• Capacity of 9	-	4,578.53	
- Per DS3	545.00	74.29	
• Capacity of 12	-	6,044.14	
- Per DS3	545.00	74.29	
• Capacity of 24	-	11,502.84	
- Per DS3	545.00	74.29	
• Capacity of 36	-	15,055.84	
- Per DS3	545.00	88.83	(T)

Qwest Corporation
Private Line Transport Services
Catalog

State of North Dakota
 Effective: 04-19-2017

SECTION 6
 Page 93
 Release 2

6. RATES AND CHARGES

6.11 DS3 SERVICE

E. Four-Year Contract (Cont'd)

	NONRECURRING CHARGE	MONTHLY RATE	(T)
2. Central Office Connecting Channel			
• Between two different DS3 services installed as two separate services	\$ 25.00	\$ 9.50	(T)
3. Transport Mileage[1]			
Mileage Bands			
• Over 0 to 8			
- Fixed	605.00	502.27	(T)
- Per mile	-	43.74	(T)
• Over 8 to 25			
- Fixed	605.00	504.69	(T)
- Per mile	-	29.88	(T)
• Over 25 to 50			
- Fixed	605.00	508.73	(T)
- Per mile	-	43.61	(T)
• Over 50			
- Fixed	605.00	526.49	(T)
- Per mile	-	49.42	(T)

[1] Nonrecurring charges apply to Transport Mileage when installed without a Channel Termination. When service involves more than one Exchange Telephone Company, one half the nonrecurring charge applies.

Qwest Corporation
Private Line Transport Services
Catalog

State of North Dakota
Effective: 04-19-2017

SECTION 6
Page 94
Release 3

6. RATES AND CHARGES

6.11 DS3 SERVICE

E. Four-Year Contract (Cont'd)

	NONRECURRING CHARGE	MONTHLY RATE	(T)
4. Optional Features and Functions			
a. Central Office Multiplexing[1]	\$355.00	\$304.00	(T)
b. Self Healing Alternate Route Protection (SHARP)[2]			
• Per DS3 Channel Termination	\$600.00	\$252.31	(T)

[1] Nonrecurring charges apply when multiplexing is not installed at the same time as a Channel Termination.

[2] Nonrecurring charges apply when the SHARP is not installed at the same time as a Channel Termination.

NOTICE
THE INFORMATION CONTAINED IN THIS DOCUMENT IS SUBJECT TO CHANGE.

Qwest Corporation
Private Line Transport Services
Catalog

State of North Dakota
 Effective: 04-19-2017

SECTION 6
 Page 95
 Release 2

6. RATES AND CHARGES

6.11 DS3 SERVICE (Cont'd)

F. Five-Year Contract

	NONRECURRING CHARGE	MONTHLY RATE	
1. Channel Termination, per termination			(T)
a. Electrical Interface			
• Capacity of 1	\$545.00	\$ 1,026.00	(T)
• Capacity of 2	-	1,672.00	
- Per DS3	545.00	138.32	
• Capacity of 3	-	1,907.60	
- Per DS3	545.00	114.76	
• Capacity of 6	-	2,967.80	
- Per DS3	545.00	72.20	
• Capacity of 9	-	4,309.20	
- Per DS3	545.00	69.92	
• Capacity of 12	-	5,688.60	
- Per DS3	545.00	69.92	
• Capacity of 24	-	10,826.20	
- Per DS3	545.00	69.92	
• Capacity of 36	-	14,170.20	
- Per DS3	545.00	83.60	(T)

Qwest Corporation
Private Line Transport Services
Catalog

State of North Dakota
 Effective: 04-19-2017

SECTION 6
 Page 96
 Release 2

6. RATES AND CHARGES

6.11 DS3 SERVICE

F. Five-Year Contract (Cont'd)

	NONRECURRING CHARGE	MONTHLY RATE	(T)
2. Central Office Connecting Channel			
• Between two different DS3 services installed as two separate services	\$ 25.00	\$ 9.50	(T)
3. Transport Mileage[1]			
Mileage Bands			
• Over 0 to 8			
- Fixed	605.00	472.72	(T)
- Per mile	-	41.00	(T)
• Over 8 to 25			
- Fixed	605.00	475.00	(T)
- Per mile	-	28.12	(T)
• Over 25 to 50			
- Fixed	605.00	478.80	(T)
- Per mile	-	40.88	(T)
• Over 50			
- Fixed	605.00	495.52	(T)
- Per mile	-	46.33	(T)

[1] Nonrecurring charges apply to Transport Mileage when installed without a Channel Termination. When service involves more than one Exchange Telephone Company, one half the nonrecurring charge applies.

NOTICE
 THE INFORMATION CONTAINED IN THIS DOCUMENT IS SUBJECT TO CHANGE.

Qwest Corporation
Private Line Transport Services
Catalog

State of North Dakota
Effective: 04-19-2017

SECTION 6
Page 97
Release 3

6. RATES AND CHARGES

6.11 DS3 SERVICE

F. Five-Year Contract (Cont'd)

	NONRECURRING CHARGE	MONTHLY RATE	(T)
4. Optional Features and Functions			
a. Central Office Multiplexing[1]	\$355.00	\$285.95	(T)
b. Self Healing Alternate Route Protection (SHARP)[2]			
• Per DS3 Channel Termination	600.00	244.74	(T)

[1] Nonrecurring charges apply when multiplexing is not installed at the same time as a Channel Termination.

[2] Nonrecurring charges apply when the SHARP is not installed at the same time as a Channel Termination.

NOTICE
THE INFORMATION CONTAINED IN THIS DOCUMENT IS SUBJECT TO CHANGE.

Qwest Corporation
Private Line Transport Services
Catalog

State of North Dakota
 Effective: 04-19-2017

SECTION 6
 Page 98
 Release 2

6. RATES AND CHARGES

6.11 DS3 SERVICE (Cont'd)

G. Six-Year Contract

	NONRECURRING CHARGE	MONTHLY RATE	
1. Channel Termination, per termination			(T)
a. Electrical Interface			
• Capacity of 1	\$545.00	\$ 993.94	(T)
• Capacity of 2	-	1,619.75	
- Per DS3	545.00	134.00	
• Capacity of 3	-	1,847.99	
- Per DS3	545.00	111.17	
• Capacity of 6	-	2,875.06	
- Per DS3	545.00	69.94	
• Capacity of 9	-	4,174.54	
- Per DS3	545.00	67.74	
• Capacity of 12	-	5,510.83	
- Per DS3	545.00	67.74	
• Capacity of 24	-	10,487.88	
- Per DS3	545.00	67.74	
• Capacity of 36	-	13,727.38	
- Per DS3	545.00	80.99	(T)

Qwest Corporation
Private Line Transport Services
Catalog

State of North Dakota
 Effective: 04-19-2017

SECTION 6
 Page 99
 Release 2

6. RATES AND CHARGES

6.11 DS3 SERVICE

G. Six-Year Contract (Cont'd)

	NONRECURRING CHARGE	MONTHLY RATE	(T)
2. Central Office Connecting Channel			
• Between two different DS3 services installed as two separate services	\$ 25.00	\$ 9.50	(T)
3. Transport Mileage[1]			
Mileage Bands			
• Over 0 to 8			
- Fixed	605.00	457.95	(T)
- Per mile	-	39.64	(T)
• Over 8 to 25			
- Fixed	605.00	460.16	(T)
- Per mile	-	27.24	(T)
• Over 25 to 50			
- Fixed	605.00	463.84	(T)
- Per mile	-	39.52	(T)
• Over 50			
- Fixed	605.00	480.04	(T)
- Per mile	-	44.79	(T)

[1] Nonrecurring charges apply to Transport Mileage when installed without a Channel Termination. When service involves more than one Exchange Telephone Company, one half the nonrecurring charge applies.

NOTICE
 THE INFORMATION CONTAINED IN THIS DOCUMENT IS SUBJECT TO CHANGE.

Qwest Corporation
Private Line Transport Services
Catalog

State of North Dakota
Effective: 04-19-2017

SECTION 6
Page 100
Release 3

6. RATES AND CHARGES

6.11 DS3 SERVICE

G. Six-Year Contract (Cont'd)

	NONRECURRING CHARGE	MONTHLY RATE	(T)
4. Optional Features and Functions			
a. Central Office Multiplexing[1]	\$355.00	\$279.30	(T)
b. Self Healing Alternate Route Protection (SHARP)[2]			
• Per DS3 Channel Termination	600.00	237.40	(T)

[1] Nonrecurring charges apply when multiplexing is not installed at the same time as a Channel Termination.

[2] Nonrecurring charges apply when the SHARP is not installed at the same time as a Channel Termination.

NOTICE
THE INFORMATION CONTAINED IN THIS DOCUMENT IS SUBJECT TO CHANGE.

Qwest Corporation
Private Line Transport Services
Catalog

State of North Dakota
 Effective: 04-19-2017

SECTION 6
 Page 101
 Release 2

6. RATES AND CHARGES

6.11 DS3 SERVICE (Cont'd)

H. Seven-Year Contract

	NONRECURRING CHARGE	MONTHLY RATE	(T)
1. Channel Termination, per termination			
a. Electrical Interface			
• Capacity of 1	\$545.00	\$ 961.88	(T)
• Capacity of 2	-	1,567.50	
- Per DS3	545.00	129.68	
• Capacity of 3	-	1,788.38	
- Per DS3	545.00	107.59	
• Capacity of 6	-	2,782.31	
- Per DS3	545.00	67.69	
• Capacity of 9	-	4,039.88	
- Per DS3	545.00	65.55	
• Capacity of 12	-	5,333.06	
- Per DS3	545.00	65.55	
• Capacity of 24	-	10,149.56	
- Per DS3	545.00	65.55	
• Capacity of 36	-	13,284.56	
- Per DS3	545.00	78.38	(T)

Qwest Corporation
Private Line Transport Services
Catalog

State of North Dakota
 Effective: 04-19-2017

SECTION 6
 Page 102
 Release 2

6. RATES AND CHARGES

6.11 DS3 SERVICE

H. Seven-Year Contract (Cont'd)

	NONRECURRING CHARGE	MONTHLY RATE	(T)
2. Central Office Connecting Channel			
• Between two different DS3 services installed as two separate services	\$ 25.00	\$ 9.50	(T)
3. Transport Mileage[1]			
Mileage Bands			
• Over 0 to 8			
- Fixed	605.00	443.18	(T)
- Per mile	-	38.61	(T)
• Over 8 to 25			
- Fixed	605.00	445.31	(T)
- Per mile	-	26.36	(T)
• Over 25 to 50			
- Fixed	605.00	448.88	(T)
- Per mile	-	38.50	(T)
• Over 50			
- Fixed	605.00	464.55	(T)
- Per mile	-	43.63	(T)

[1] Nonrecurring charges apply to Transport Mileage when installed without a Channel Termination. When service involves more than one Exchange Telephone Company, one half the nonrecurring charge applies.

NOTICE
 THE INFORMATION CONTAINED IN THIS DOCUMENT IS SUBJECT TO CHANGE.

Qwest Corporation
Private Line Transport Services
Catalog

State of North Dakota
Effective: 04-19-2017

SECTION 6
Page 103
Release 3

6. RATES AND CHARGES

6.11 DS3 SERVICE

H. Seven-Year Contract (Cont'd)

	NONRECURRING CHARGE	MONTHLY RATE	(T)
4. Optional Features and Functions			
a. Central Office Multiplexing[1]	\$355.00	\$271.70	(T)
b. Self Healing Alternate Route Protection (SHARP)[2]			
• Per DS3 Channel Termination	600.00	230.28	(T)

[1] Nonrecurring charges apply when multiplexing is not installed at the same time as a Channel Termination.

[2] Nonrecurring charges apply when the SHARP is not installed at the same time as a Channel Termination.

NOTICE
THE INFORMATION CONTAINED IN THIS DOCUMENT IS SUBJECT TO CHANGE.

Qwest Corporation
Private Line Transport Services
Catalog

State of North Dakota
 Effective: 04-19-2017

SECTION 6
 Page 104
 Release 2

6. RATES AND CHARGES

6.11 DS3 SERVICE (Cont'd)

I. Eight-Year Contract

	NONRECURRING CHARGE	MONTHLY RATE	(T)
1. Channel Termination, per termination			
a. Electrical Interface			
• Capacity of 1	\$545.00	\$ 942.64	(T)
• Capacity of 2	-	1,536.15	
- Per DS3	545.00	127.08	
• Capacity of 3	-	1,752.61	
- Per DS3	545.00	105.44	
• Capacity of 6	-	2,726.67	
- Per DS3	545.00	66.33	
• Capacity of 9	-	3,959.08	
- Per DS3	545.00	64.24	
• Capacity of 12	-	5,226.40	
- Per DS3	545.00	64.24	
• Capacity of 24	-	9,946.57	
- Per DS3	545.00	64.24	
• Capacity of 36	-	13,018.87	
- Per DS3	545.00	76.81	(T)

Qwest Corporation
Private Line Transport Services
Catalog

State of North Dakota
 Effective: 04-19-2017

SECTION 6
 Page 105
 Release 2

6. RATES AND CHARGES

6.11 DS3 SERVICE

I. Eight-Year Contract (Cont'd)

	NONRECURRING CHARGE	MONTHLY RATE	(T)
2. Central Office Connecting Channel			
• Between two different DS3 services installed as two separate services	\$ 25.00	\$ 9.50	(T)
3. Transport Mileage[1]			
Mileage Bands			
• Over 0 to 8			
- Fixed	605.00	434.31	(T)
- Per mile	-	37.93	(T)
• Over 8 to 25			
- Fixed	605.00	436.41	(T)
- Per mile	-	25.84	(T)
• Over 25 to 50			
- Fixed	605.00	439.90	(T)
- Per mile	-	37.82	(T)
• Over 50			
- Fixed	605.00	455.26	(T)
- Per mile	-	42.86	(T)

[1] Nonrecurring charges apply to Transport Mileage when installed without a Channel Termination. When service involves more than one Exchange Telephone Company, one half the nonrecurring charge applies.

NOTICE
 THE INFORMATION CONTAINED IN THIS DOCUMENT IS SUBJECT TO CHANGE.

Qwest Corporation
Private Line Transport Services
Catalog

State of North Dakota
Effective: 04-19-2017

SECTION 6
Page 106
Release 3

6. RATES AND CHARGES

6.11 DS3 SERVICE

I. Eight-Year Contract (Cont'd)

	NONRECURRING CHARGE	MONTHLY RATE	(T)
4. Optional Features and Functions			
a. Central Office Multiplexing[1]	\$355.00	\$265.05	(T)
b. Self Healing Alternate Route Protection (SHARP)[2]			
• Per DS3 Channel Termination	600.00	223.37	(T)

[1] Nonrecurring charges apply when multiplexing is not installed at the same time as a Channel Termination.

[2] Nonrecurring charges apply when the SHARP is not installed at the same time as a Channel Termination.

NOTICE
THE INFORMATION CONTAINED IN THIS DOCUMENT IS SUBJECT TO CHANGE.

Qwest Corporation
Private Line Transport Services
Catalog

State of North Dakota
 Effective: 04-19-2017

SECTION 6
 Page 107
 Release 2

6. RATES AND CHARGES

6.11 DS3 SERVICE (Cont'd)

J. Nine-Year Contract

	NONRECURRING CHARGE	MONTHLY RATE	(T)
1. Channel Termination, per termination			
a. Electrical Interface			
• Capacity of 1	\$545.00	\$ 923.40	(T)
• Capacity of 2	-	1,504.80	
- Per DS3	545.00	124.49	
• Capacity of 3	-	1,716.84	
- Per DS3	545.00	103.28	
• Capacity of 6	-	2,671.02	
- Per DS3	545.00	64.98	
• Capacity of 9	-	3,878.28	
- Per DS3	545.00	62.93	
• Capacity of 12	-	5,119.74	
- Per DS3	545.00	62.93	
• Capacity of 24	-	9,743.58	
- Per DS3	545.00	62.93	
• Capacity of 36	-	12,753.18	
- Per DS3	545.00	75.24	(T)

Qwest Corporation
Private Line Transport Services
Catalog

State of North Dakota
 Effective: 04-19-2017

SECTION 6
 Page 108
 Release 2

6. RATES AND CHARGES

6.11 DS3 SERVICE

J. Nine-Year Contract (Cont'd)

	NONRECURRING CHARGE	MONTHLY RATE	(T)
2. Central Office Connecting Channel			
• Between two different DS3 services installed as two separate services	\$ 25.00	\$ 9.50	(T)
3. Transport Mileage[1]			
Mileage Bands			
• Over 0 to 8			
- Fixed	605.00	425.45	(T)
- Per mile	-	36.90	(T)
• Over 8 to 25			
- Fixed	605.00	427.50	(T)
- Per mile	-	25.31	(T)
• Over 25 to 50			
- Fixed	605.00	430.92	(T)
- Per mile	-	36.80	(T)
• Over 50			
- Fixed	605.00	445.97	(T)
- Per mile	-	41.70	(T)

[1] Nonrecurring charges apply to Transport Mileage when installed without a Channel Termination. When service involves more than one Exchange Telephone Company, one half the nonrecurring charge applies.

NOTICE
 THE INFORMATION CONTAINED IN THIS DOCUMENT IS SUBJECT TO CHANGE.

Qwest Corporation
Private Line Transport Services
Catalog

State of North Dakota
Effective: 04-19-2017

SECTION 6
Page 109
Release 3

6. RATES AND CHARGES

6.11 DS3 SERVICE

J. Nine-Year Contract (Cont'd)

	NONRECURRING CHARGE	MONTHLY RATE	(T)
4. Optional Features and Functions			
a. Central Office Multiplexing[1]	\$355.00	\$257.45	(T)
b. Self Healing Alternate Route Protection (SHARP)[2]			
• Per DS3 Channel Termination	600.00	216.67	(T)

[1] Nonrecurring charges apply when multiplexing is not installed at the same time as a Channel Termination.

[2] Nonrecurring charges apply when the SHARP is not installed at the same time as a Channel Termination.

NOTICE
THE INFORMATION CONTAINED IN THIS DOCUMENT IS SUBJECT TO CHANGE.

Qwest Corporation
Private Line Transport Services
Catalog

State of North Dakota
 Effective: 04-19-2017

SECTION 6
 Page 110
 Release 2

6. RATES AND CHARGES

6.11 DS3 SERVICE (Cont'd)

K. Ten-Year Contract

	NONRECURRING CHARGE	MONTHLY RATE	
1. Channel Termination, per termination			(T)
a. Electrical Interface			
• Capacity of 1	\$545.00	\$ 897.75	(T)
• Capacity of 2	-	1,463.00	
- Per DS3	545.00	121.03	
• Capacity of 3	-	1,669.15	
- Per DS3	545.00	100.42	
• Capacity of 6	-	2,596.83	
- Per DS3	545.00	63.18	
• Capacity of 9	-	3,770.55	
- Per DS3	545.00	61.18	
• Capacity of 12	-	4,977.53	
- Per DS3	545.00	61.18	
• Capacity of 24	-	9,472.93	
- Per DS3	545.00	61.18	
• Capacity of 36	-	12,398.93	
- Per DS3	545.00	73.15	(T)

Qwest Corporation
Private Line Transport Services
Catalog

State of North Dakota
 Effective: 04-19-2017

SECTION 6
 Page 111
 Release 2

6. RATES AND CHARGES

6.11 DS3 SERVICE

K. Ten-Year Contract (Cont'd)

	NONRECURRING CHARGE	MONTHLY RATE	(T)
2. Central Office Connecting Channel			
• Between two different DS3 services installed as two separate services	\$ 25.00	\$ 9.50	(T)
3. Transport Mileage[1]			
Mileage Bands			
• Over 0 to 8			
- Fixed	605.00	413.63	(T)
- Per mile	-	35.88	(T)
• Over 8 to 25			
- Fixed	605.00	415.63	(T)
- Per mile	-	24.61	(T)
• Over 25 to 50			
- Fixed	605.00	418.95	(T)
- Per mile	-	35.77	(T)
• Over 50			
- Fixed	605.00	433.58	(T)
- Per mile	-	40.54	(T)

[1] Nonrecurring charges apply to Transport Mileage when installed without a Channel Termination. When service involves more than one Exchange Telephone Company, one half the nonrecurring charge applies.

Qwest Corporation
Private Line Transport Services
Catalog

State of North Dakota
Effective: 04-19-2017

SECTION 6
Page 112
Release 4[3]

6. RATES AND CHARGES

6.11 DS3 SERVICE

K. Ten-Year Contract (Cont'd)

	NONRECURRING CHARGE	MONTHLY RATE	(T)
4. Optional Features and Functions			
a. Central Office Multiplexing[1]	\$355.00	\$249.85	(T)
b. Self Healing Alternate Route Protection (SHARP)[2]			
• Per DS3 Channel Termination	600.00	210.17	(T)

[1] Nonrecurring charges apply when multiplexing is not installed at the same time as a Channel Termination.

[2] Nonrecurring charges apply when the SHARP is not installed at the same time as a Channel Termination.

[3] This page cancels Pages 113 through 118, Release 1.

NOTICE
THE INFORMATION CONTAINED IN THIS DOCUMENT IS SUBJECT TO CHANGE.